

Improving the Efficiency and Attractiveness of Vocational Education/Training of Electricians

Erasmus+ Project Nr. 2021-1-DE02-KA220-VET-000029591

Project ID: 2021-1-DE02-KA220-VET-000029591

Web-based VET modules in the energy efficiency of intelligent buildings for electricians: EE-VET

Module 3: Photovoltaic Technology and Systems



This work is marked with CC0 1.0. To view a copy of this license, visit

<https://creativecommons.org/publicdomain/zero/1.0/>

By marking the work with a CC0 public domain dedication, the creator is giving up their copyright and allowing reusers to distribute, remix, adapt, and build upon the material in any medium or format, even for commercial purposes.



Co-funded by
the European Union

Funded by the European Union. Views and opinions expressed are however those of the author(s) only and do not necessarily reflect those of the European Union or the European Education and Culture Executive Agency (EACEA). Neither the European Union nor EACEA can be held responsible for them.

- 1. Photovoltaic Systems - Basics**
- 2. Basic components in photovoltaic system architecture**
- 3. Site survey and shading analysis are important elements for the proper functioning and efficiency of the PV system.**
- 4. Installation of a PV system depending on the purpose and according to the architectural features of the building.**
- 5. Safety rules for installation and operation. Basic steps for building a PV system.**



1. Photovoltaic Systems - Basics

Content

- 1.1. Sun and solar Radiation
- 1.2. Photovoltaic effect and principle of solar cells operation.
- 1.3. Types of technologies for creating PV cells.
- 1.4. A brief overview of the types of photovoltaic systems and their application.
- 1.5. Evaluation and analysis of the terrain/building based on which the PV system must be introduced.
- 1.6. Main steps and activities to be planned to realise a small PV system.



1.1. Sun and solar Radiation 1.1.1. The sun as an energy source

This lesson primarily focuses on solar radiation. We will delve into the sun's role as an energy source, particularly in the context of photovoltaic systems. It will cover essential parameters such as the power and energy of solar radiation that reaches the Earth, along with its spectral composition. Additionally, we'll explore commonly used angle definitions and investigate the potential additional yield achievable through tracking PV systems. The lesson will also demonstrate various measuring instruments used to gauge the amount of solar radiation on an object."



Figure: The sun source: <https://www.shutterstock.com/th/search/sun-space>

1.1.1. The sun as an energy source

The sun sustains life on Earth by providing energy in the form of radiation. This energy is generated within the sun through the fusion of hydrogen nuclei into helium nuclei, a process wherein a fraction of mass is transformed into energy. Essentially, the sun acts as an enormous fusion reactor.

However, due to the vast distance between the sun and Earth, only a minuscule portion (about two millionths) of the solar radiation emitted by the sun actually reaches the Earth's surface. This minute fraction corresponds to an energy amount of 1×10^{18} kWh/a.

When compared to the worldwide annual energy consumption and the reserves of fossil and nuclear energy sources, this amount is relatively small. The conventional energy sources, predominantly utilized in the industrial era, are finite and depletable. The availability of safely recoverable quantities of crude oil and natural gas is anticipated to decline, potentially



leading to a shortage of supplies, both from technical and economic perspectives, in the first third of this century. Even if significant new reserves were discovered, they would only extend the fossil fuel reserves by a limited number of years.

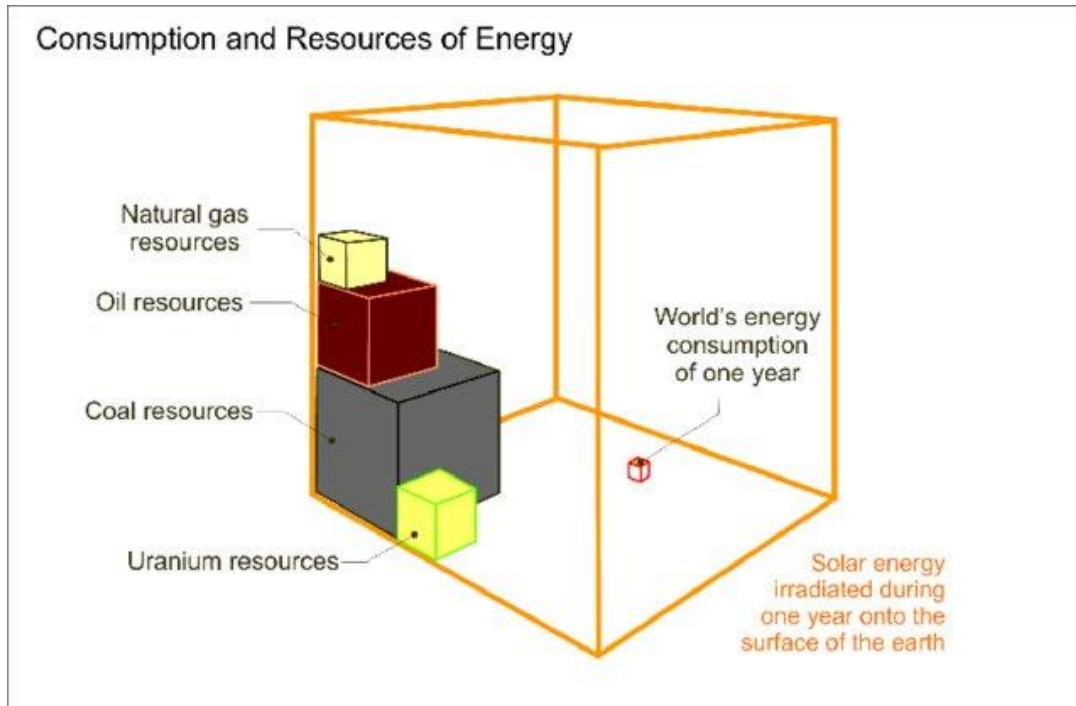

Figure: World energy consumption in comparison to world fossil resources and annual solar energy potential, source: Krauter 2006, p.2; adapted from Greenpeace

1.1.2. The power of solar radiation

The intensity of solar radiation outside Earth's atmosphere varies due to the planet's elliptical orbit around the sun. Throughout the year, the Earth's distance from the sun changes, fluctuating between 147 and 152 million kilometers.

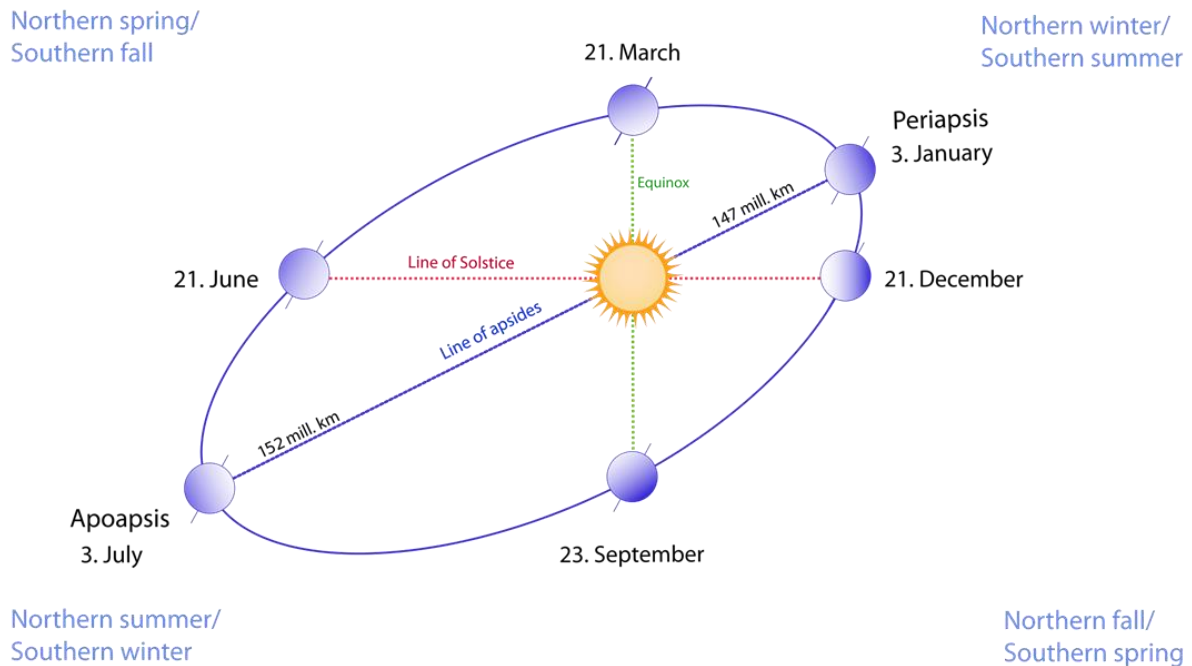

Figure : Earth's orbit around the sun sorces: [wikimedia.org](https://commons.wikimedia.org/wiki/File:Earth_orbit_around_sun.png)

Consequently, the solar radiation falling on a surface perpendicular to the sun's rays, denoted as E_0 , ranges from 1325 W/m^2 to 1420 W/m^2 over the course of a year. The average annual value of this radiation is termed the solar constant:

Solar constant: $GSC = 1367 \text{ W/m}^2$.

The Dimensional formula for solar constant. The solar constant is the incident ray of solar energy per unit area per second on the earth surface.

Solar constant = Energy / (Unit area x Unit time) = $ML^2T^{-2} / (L^2T) = MT^{-3}$

It's important to note that the solar constant encompasses all forms of solar radiation, not limited to visible light.

The solar constant experiences a slight variation of approximately +/-3% due to Earth's slightly elliptical orbit around the sun. When Earth is at perihelion, typically in the first week of January, the Sun-Earth distance is shorter, whereas it is at aphelion, usually in the first week of July, when the distance is greater. This solar constant is calculated concerning the average Earth-Sun distance, known as one Astronomical Unit (AU), equivalent to 149.59787066 million kilometers.

1.1.3. Distribution of solar radiation and Spectrum of the sunlight

Distribution of solar radiation and Spectrum of the sunlight

The solar radiation reaching Earth undergoes various interactions within the atmosphere, leading to reduction by means of reflection, absorption (primarily by ozone, water vapor, oxygen, and carbon dioxide), and scattering (caused by air molecules, dust particles, and impurities). On clear days, around midday, the Earth's surface receives an irradiance of approximately $1,000 \text{ W/m}^2$. Interestingly, this value remains relatively consistent regardless of location. However, the highest irradiances are typically observed on partially cloudy, sunny days. Passing clouds reflecting solar radiation can lead to short-lived irradiance spikes, occasionally reaching up to $1,400 \text{ W/m}^2$. This solar irradiance is often termed instantaneous global irradiance.

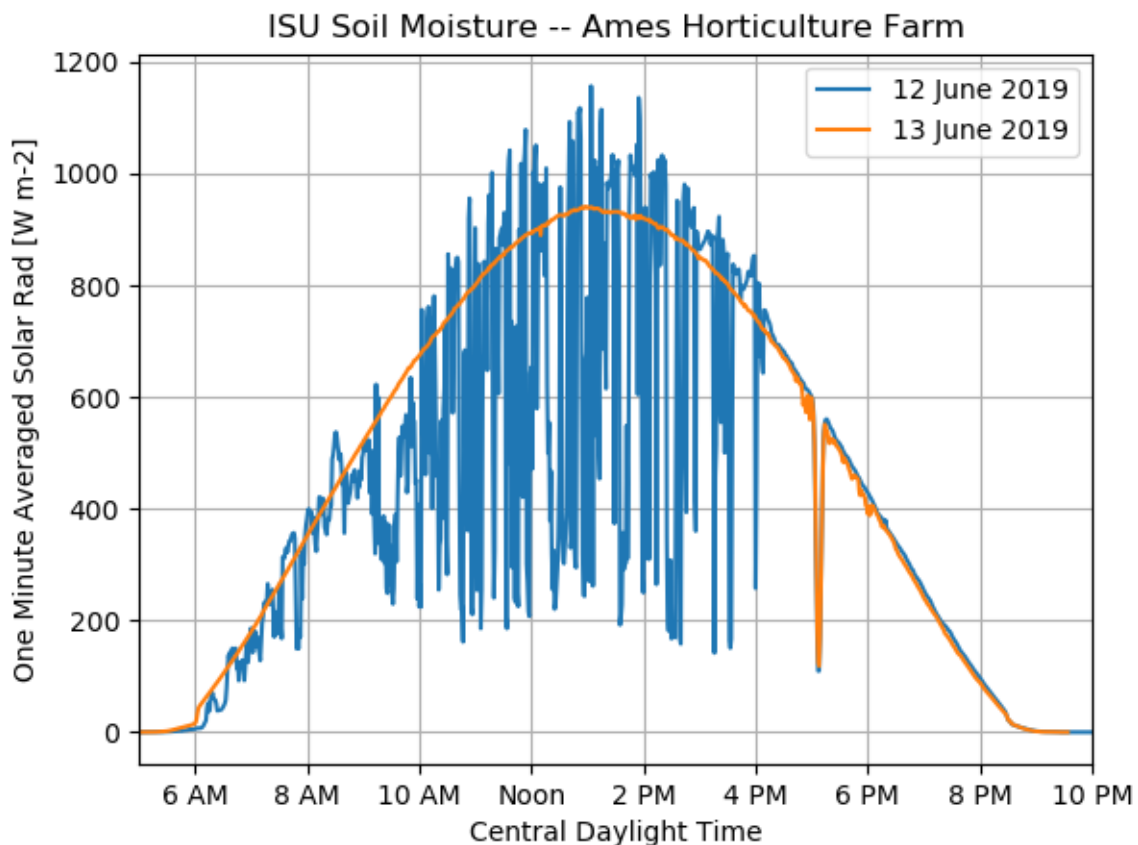

Figure : Horizontal irradiance on a clear and on a partly cloudy summer day
(<https://mesonet.agron.iastate.edu/onsite/features/cat.php?day=2019-06-14>)

On loosely cloudy days, the temperatures of solar modules register notably lower values compared to clear days. This temperature behavior of photovoltaic (PV) modules correlates with the solar generator's output, resulting in brief peaks in energy production on such days.

1.1.4. The energy of solar radiation

The variation in annual solar radiation, measured in kWh/m², is substantial across different regions globally. Regions closer to the equator experience higher solar energy, with some areas exceeding 2300 kWh/m² per year.

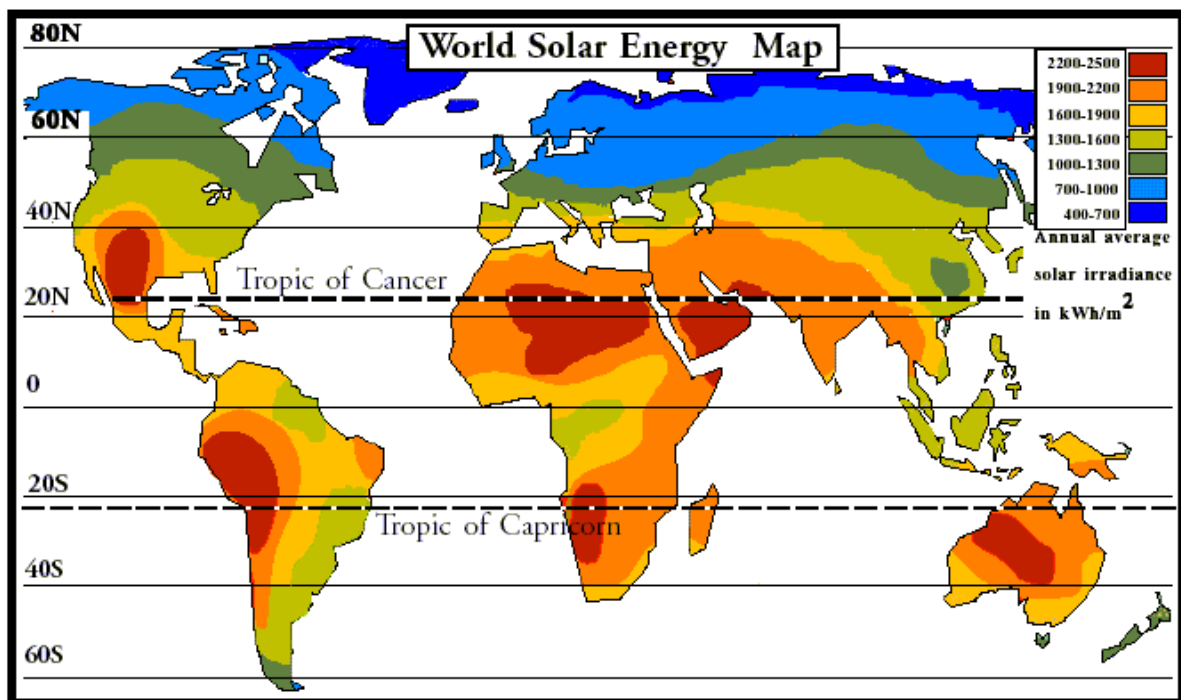

Figure : Worldwide distribution of annual solar radiation on the horizontal in kWh/m²
<https://www.inforse.org/europe/dieret/Solar/solar.html>

In Southern Europe, the maximum annual solar radiation drops to around 1700 kWh/m², while Central Europe averages approximately 1048 kWh/m² annually. These discrepancies in solar energy are attributed to factors such as geographical location, topography, and seasonal changes. These differences can be observed not only between different European countries but also within distinct seasons of the year.

1.1.5. Direct, diffuse, and global radiation

The sunlight reaching the Earth's surface comprises two main components: direct and diffuse radiation. Direct radiation travels through the atmosphere without deviation and strikes the Earth's surface in a straight line. On the other hand, diffuse radiation is scattered in various directions by particles like air, dust, water molecules, and surface objects, creating a uniform spread of light. Additionally, when direct radiation is reflected by objects on the Earth's surface, it contributes to the diffuse component, often referred to as Albedo. The combination of these components is known as global radiation.

Solar radiation reaching photovoltaic panels can consist of direct, diffuse, and reflected components, affecting energy absorption and conversion (see figure).

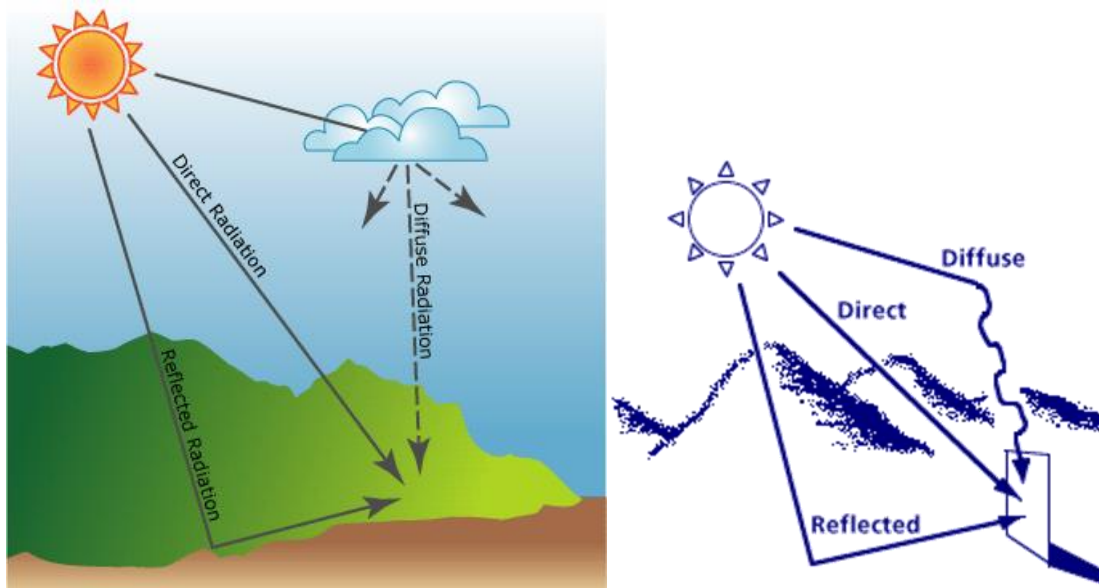

Figure : Sunlight passing through the atmosphere

The proportion of direct and diffuse radiation varies based on factors like cloud cover and the sun's position in the sky. On clear days, direct radiation tends to dominate the total radiation. Conversely, on cloudy days, especially during winter, the solar radiation tends to be predominantly diffuse, with minimal direct radiation.

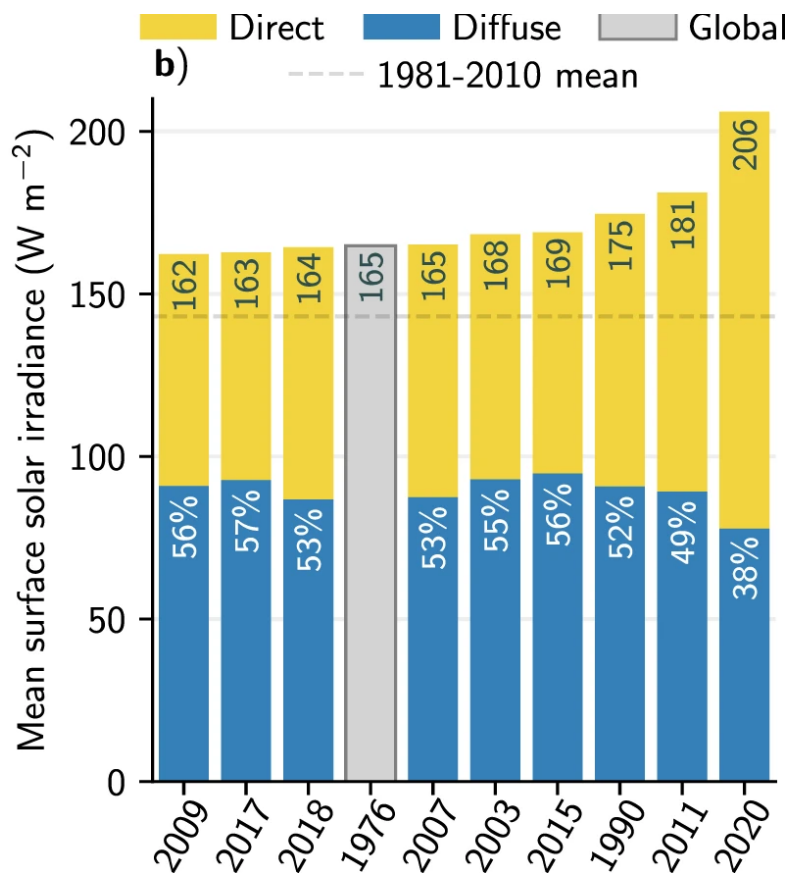

Figure: Typical course of the annual values of direct and diffuse radiation measured by the Veenkampen station in the Netherlands for the area of Western Europe. (doi.org/10.1038/s43247-021-00110-0 17)

In the context of Poland and the Baltic region, diffuse solar radiation accounts for approximately 60% throughout the year, while direct radiation constitutes around 40%. In Central Europe, both direct and diffuse radiation are relatively evenly distributed. Comparatively, in southern Europe, the share of direct radiation is higher at about 65%.

1.1.6 The angles definitions

The accurate calculation of solar radiation received by photovoltaic panels relies on understanding the sun's position, described by specific angles: solar elevation, solar azimuth, and other related angles. These angles play a pivotal role in determining the optimal design and efficiency of photovoltaic systems in specific locations. Here's an overview of these angles:



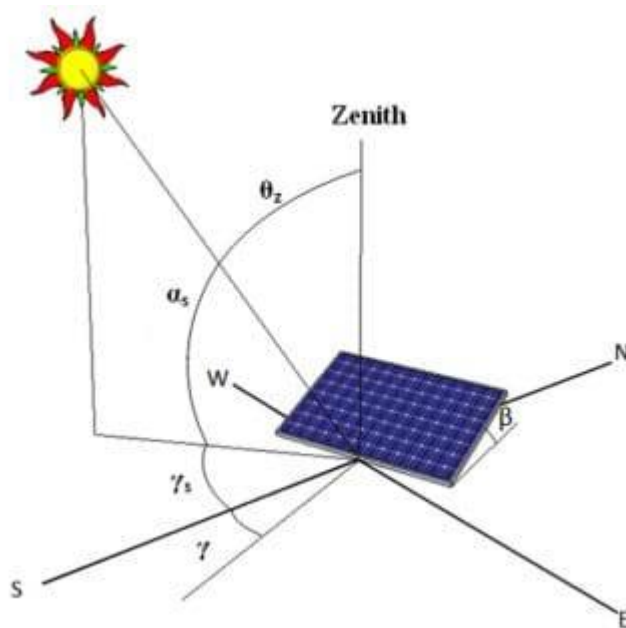

Figure: Angle designation of the sun position according to DIN 5034

Zenith Angle, Θ_z : Zenith Angle (Θ_z): The angle between the line pointing towards the sun and the vertical. It signifies the sun's position in the sky. At sunrise and sunset, this angle measures 90° .

Solar Altitude Angle (α_s): The angle between the line pointing to the sun and the horizontal plane. It complements the zenith angle. It's 0° at sunrise and sunset.

Solar Azimuth Angle (γ_s): The angle between the line pointing to the sun and the south direction. Negative angles are towards the east, and positive angles are towards the west. At solar noon, this angle is 0° . It's close to -90° at sunrise and 90° at sunset, depending on the season. It's measured only in the horizontal plane, disregarding the sun's height.

Angle of Incidence (θ): The angle between the line pointing to the sun and the line normal to the surface of the PV panel. It's crucial for efficiency, as solar panels perform best when directly facing the sun.

Hour Angle (ω): It determines the sun's angular displacement east or west of the local meridian. Earth's rotation is 15° per hour, making the hour angle -15° at 11 am and 15° at 1 pm.



Surface Azimuth Angle (γ): This angle is between the line normal to the PV panel surface and the south direction, measured in the horizontal plane. East is negative, west is positive.

Collector Slope (β): It indicates the angle between the solar collector's plane and the horizontal. It increases as the panel tilts up.

Declination (δ): The angle between the line from the equator pointing to the sun and the line pointing out from the equator at solar noon. It varies between 23.45 and -23.45 throughout the year, contributing to seasonal changes.

Latitude (ϕ): The angle between the line from the Earth's center to a location on its surface and the line from the Earth's center to the equator. It can be easily found on a map.

These angles collectively determine the amount and direction of solar radiation received by PV panels, impacting their performance and efficiency.

1.1.7. The angles in solar technology

The optimal angle for solar panels in your solar system varies based on your geographic location. Solar panels generate the most energy when directly facing the sun. As the sun's position changes throughout the day and seasons, the ideal angle is not fixed. To maximize sunlight reaching the panels throughout the day, determining the panels' direction and calculating the best tilt angle is crucial. This depends on:

Your geographical location

The time of year when you require the most solar energy



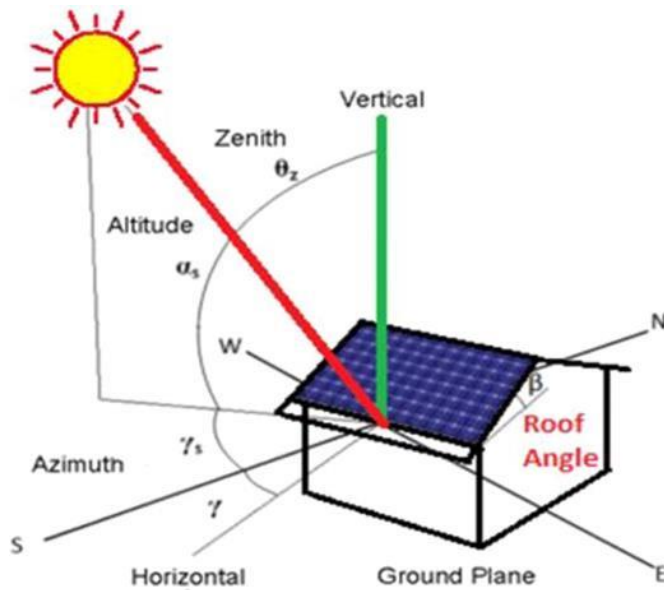

Figure : Angle designation in solar technology (The analysis on the impact of the roof angle on electricity energy generation of photovoltaic panels in Kahramanmaras, Turkey—A case study for all seasons: Journal of Renewable and Sustainable Energy: Vol 7,)

Calculation of the Optimal Solar Panel Angle

As a rule, solar panels should be more vertical during winter to capture the lower winter sun and more tilted during summer for increased output. Here are two methods to estimate the solar panel angle based on your latitude.

Method One

During winter, the optimal tilt angle is your latitude plus 15 degrees, while during summer, it is your latitude minus 15 degrees. For instance, if your latitude is 34° , the winter tilt angle would be $34 + 15 = 49^\circ$, and the summer angle would be $34 - 15 = 19^\circ$.

Method Two

An improved method providing more accurate results involves specific angle calculations. For winter, multiply your latitude by 0.9 and add 29° . For example, with a latitude of 34° , the winter tilt angle becomes $(34 * 0.9) + 29 = 59.6^\circ$. This angle, steeper by 10° compared to the general method, efficiently captures the midday sun, crucial during short winter days. For summer, multiply the latitude by 0.9 and subtract 23.5° . Using the same latitude of 34° , this



gives a summer angle of $(34 * 0.9) - 23.5 = 7.1^\circ$. During spring and fall, subtract 2.5° from the latitude for the optimum tilt angles.

These calculated angles assist in maximizing solar panel efficiency throughout the year, capturing the most sunlight for energy production.

1.1.8. The Position, Elevation Angle and Air Mass of Sun

Position of the Sun - Sun elevation angle and AirMass

The position of the Sun significantly affects solar irradiance, with solar elevation angles playing a crucial role. This angle is measured from the horizontal plane. As the Sun's position changes throughout the day and across seasons, the elevation angle varies. When the Sun is positioned vertically, its light takes the shortest path through the atmosphere. Conversely, when the Sun is at a lower angle, its path through the atmosphere is longer, leading to increased absorption and scattering of solar radiation. This results in reduced radiation intensity.

The AirMass (AM) factor represents the frequency with which sunlight traverses the Earth's atmosphere, equivalent to one atmospheric thickness. The correlation between the Sun's position (altitude) and AirMass is defined mathematically as:

$$AM = 1/\cos \theta_z$$

Here, when the Sun is at a perpendicular position ($\theta_z = 90^\circ$), AM equals 1. This scenario reflects the Sun's position at the equator around noon during the start of spring or fall. At this point, the Sun's rays strike the Earth's surface at a right angle, leading to the lowest AirMass value of 1.



Designation of Solar Air Masses

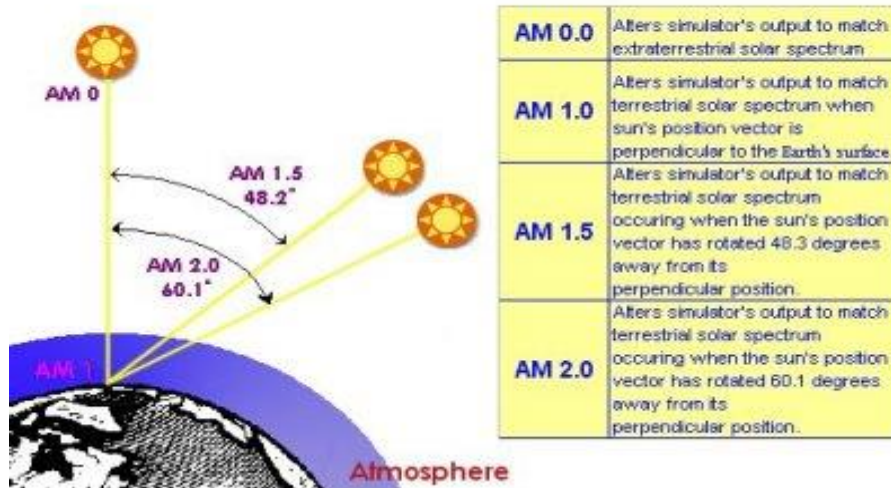

Figure: Designation of the solar air masses,

source:https://www.daviddarling.info/encyclopedia/A/AE_air_mass.html

Air mass (AM) represents the distance light travels through Earth's atmosphere. Despite the Sun emitting a vast amount of radiant energy into space, only a small fraction, about 1367 watts (W) per square meter (m²), reaches the outer edge of Earth's atmosphere. This energy undergoes absorption and reflection by the atmosphere, with some high-energy rays like X-rays and ultraviolet rays being absorbed.

When this energy reaches the Earth's surface, it's subject to energy loss based on the atmosphere's thickness it traverses. At high noon on a clear day, the radiation reaching sea level amounts to 1000 W/m², termed "air mass 1" (AM1) radiation. As the Sun moves lower in the sky, the light travels through a longer path of air, resulting in greater energy loss. As a result, the available energy becomes less than 1000 W/m².

Standard solar spectra at the Earth's surface are categorized as AM1.5G ("G" includes direct and diffuse radiation) or AM1.5D (direct radiation only). The "1.5" indicates the path length of light through the atmosphere is 1.5 times longer than the shorter path when the Sun is directly overhead.

In contrast, the standard spectrum outside Earth's atmosphere is referred to as AM0, often used to forecast solar cell performance in space. To approximate the intensity of AM1.5D radiation, the AM0 spectrum is reduced by 28%, considering 18% absorbed and 10% scattered. The global spectrum, AM1.5G, is around 10% higher than the direct spectrum. However, despite calculations yielding approximately 970 W/m² for AM1.5G, the standard AM1.5G spectrum is "normalized" to 1000 W/m² due to inherent variations in incident solar radiation.



1.1.9. The Spectrum of the Sunlight

The Sun radiates a broad spectrum of electromagnetic waves, ranging from X-rays to radio waves, with its peak emission occurring in visible wavelengths (refer to the figure below). Radiation energy is typically measured in joules per second per square meter ($J/s/m^2$) for specific wavelengths, usually measured in nanometers (nm).

A few notable observations from the solar spectrum graph are as follows:

Approximately half of the Sun's energy lies within the visible range, below $0.7 \mu m$. This can be determined through [integration](#).

High-altitude ozone (O_3) and oxygen (O_2) absorb a significant portion of ultraviolet (UV) radiation below 300 nm in the atmosphere.

Roughly 70% of visible radiation penetrates through the atmosphere to reach sea level.

Ozone absorbs minimal visible radiation, whereas a substantial part gets scattered by clouds and aerosol, with some being reflected back into space without impacting Earth's energy system.

Certain atmospheric constituents like water vapor, carbon dioxide (CO_2), and ozone absorb specific bands of infrared radiation.

In the regions where these gases absorb strongly, the solar irradiance at sea level is relatively low.



Spectrum of Solar Radiation (Earth)

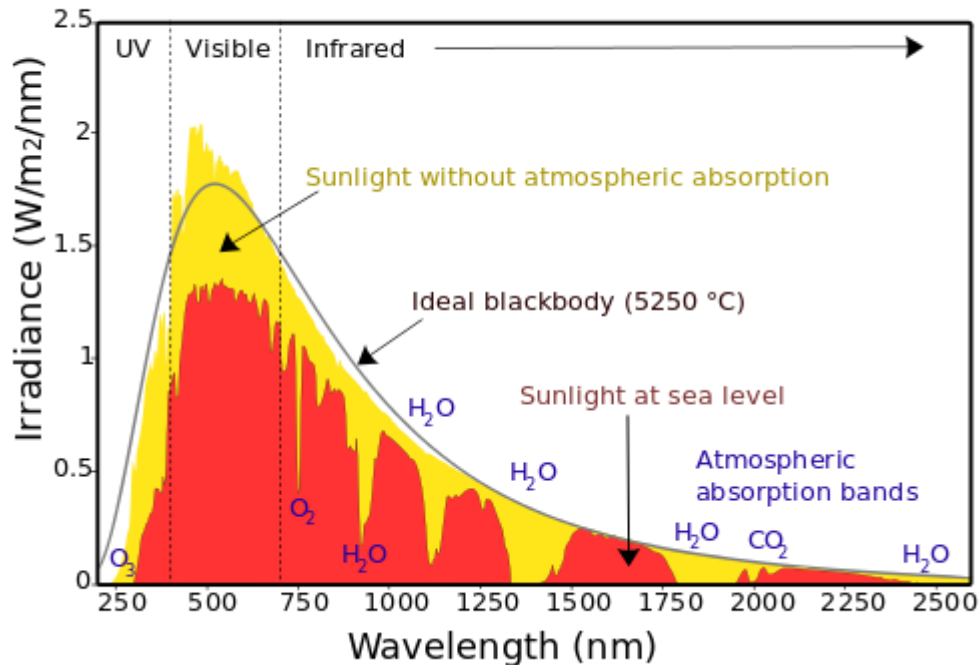

Figure : Solar spectrum and atmospheric absorbing gases from 240 nm to 2.5 μm wavelengths. source: <https://www.e-education.psu.edu/meteo300/node/683>

While the visible part of the solar spectrum is the most intense and visible to the human eye, the Sun emits electromagnetic radiation, extending beyond what's visible, from ultraviolet to infrared. The Sun's temperature, around 5800 Kelvin, contributes to its spectrum peaking in the visible part due to its high temperature in the photosphere.

It's noteworthy that although the Sun produces gamma rays through nuclear fusion, these rays do not reach its surface. The extremely high-energy photons convert into lower energy forms before emission into space.

The solar spectrum also exhibits wave-particle duality, showcasing characteristics of both waves and particles. While in motion, light behaves akin to a wave, but upon interaction or interception, it returns to particle-like behavior.

1.1.10. The Sunlight Spectrum - influence of elevation angle and clouds

Spectrum of Sunlight - influence of elevation angle and clouds

Solar irradiance undergoes reduction as it traverses the Earth's atmosphere due to several factors:



Reflection by the atmosphere: Some incident solar radiation gets reflected away from the Earth's surface by components within the atmosphere.

Absorption by atmospheric molecules: Certain molecules present in the atmosphere absorb a portion of incoming sunlight.

Rayleigh scattering: This scattering occurs due to interactions with air molecules, leading to scattering of shorter wavelengths, especially blue light.

Mie scattering: Scattering by impurities in the air, known as Mie scattering, has a considerable impact on irradiance, notably in industrial areas. It can significantly influence the sunlight's path.

The relationship between irradiance and the sun's elevation angle is notable. Lower sun elevations correspond to increased absorption and Rayleigh scattering, which tend to diminish the amount of solar irradiation reaching the Earth's surface.

Moreover, Mie scattering, particularly influenced by local conditions, notably industrial activities, exerts a stronger influence in certain locations. These impurities in the air contribute to additional scattering, further affecting the amount of sunlight that reaches the surface.

Local weather conditions like cloud cover, precipitation (rain or snowfall), and other meteorological factors play a crucial role in further attenuating solar irradiance. Clouds, in particular, can significantly reduce the amount of sunlight reaching the Earth's surface due to their reflective and absorptive properties. Therefore, variations in weather conditions have a substantial impact on the final amount of solar radiation that reaches the ground level.

Table: Dependence of irradiation on elevation angle α_s

γ_s	AM	Absorption	Rayleigh-Streuung	Mie-Streuung	Gesamt-schwächung
90°	1,00	8,7 %	9,4 %	0 ... 25,6 %	17,3 ... 38,5 %
60°	1,15	9,2 %	10,5 %	0,7 ... 29,5 %	19,4 ... 42,8 %
30°	2,00	11,2 %	16,3 %	4,1 ... 44,9 %	28,8 ... 59,1 %
10°	5,76	16,2 %	31,9 %	15,4 ... 74,3 %	51,8 ... 85,4 %
5°	11,5	19,5 %	42,5 %	24,6 ... 86,5 %	65,1 ... 93,8 %

1.1.11. The global radiation as a function of azimuth and inclination

Global solar radiation received by a surface oriented perpendicular to the incident solar rays consistently exceeds that of an equivalent horizontal surface. Considering the changing



azimuth and solar elevation angles throughout the day and year, varying angles of solar radiation incidence are anticipated on fixed surfaces like house roofs. Evaluating the annual radiation supply aids in assessing the suitability of existing surfaces for solar utilization. The accompanying graph depicts the long-term average of yearly solar irradiance per square meter in relation to azimuth and inclination, as calculated for Delft by Solar3Dcity.

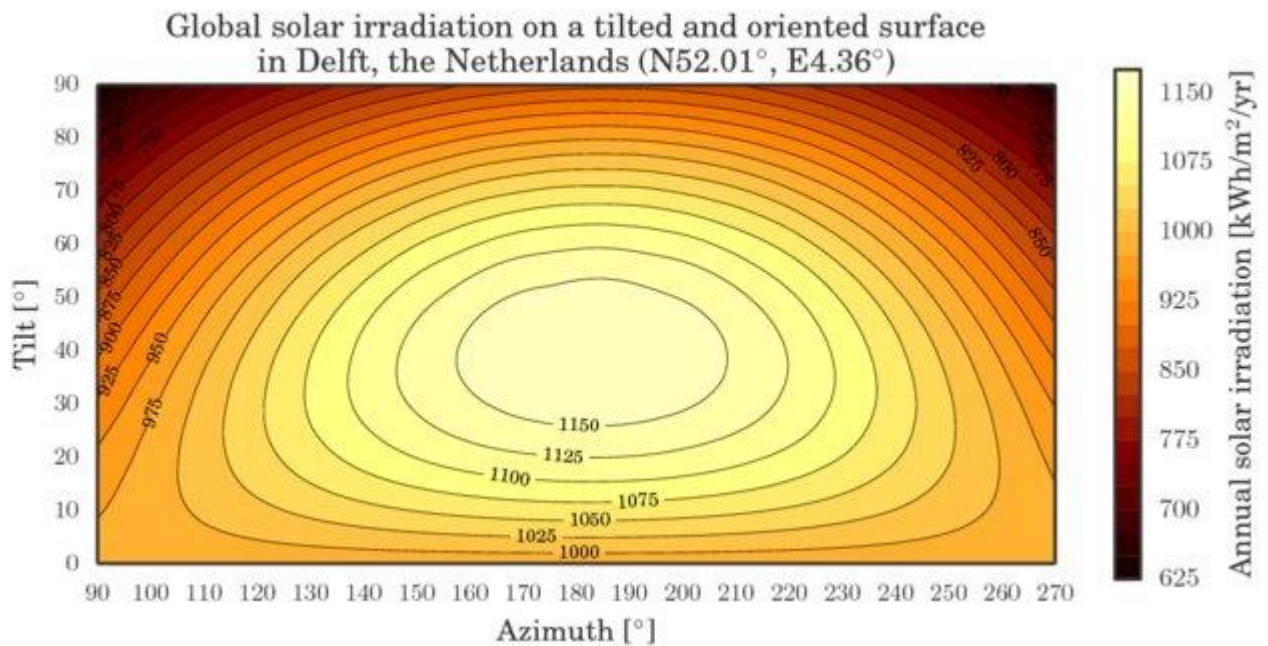

Figure : Annual sum of global radiation in Delft as a function of azimuth and inclination in kW/m²/yr, source: DOI:[10.1080/13658816.2015.1073292](https://doi.org/10.1080/13658816.2015.1073292)

The graph portrays annual global solar irradiance concerning surface inclination and azimuth, with the plot's center facing south, flanked by west and east orientations, representing half of the complete azimuth range. Analysis of this plot reveals substantial variations in solar radiation across surfaces oriented and inclined differently. This underscores the importance of employing 3D models in designing **photovoltaic** systems.

Key findings suggest that solar system orientation significantly influences radiation acquisition:

Panels set vertically exhibit approximately 15% higher radiation than those on a horizontal surface ($\beta = 0^\circ$).

Installation of solar systems on pitched roofs, oriented between south-west and south-east, or with slopes ranging between 10° and 50° , results in, at most, a 10% decrease in yields, making them recommendable for solar usage without constraints on their orientation.

Roofs deviating further from the ideal position can still be utilized, although reduced exposure may raise economic viability concerns.

For solar use on facades ($\beta = 90^\circ$), irradiation and expected yields are notably lower. However, visibility of the solar system, design considerations, and synergies in construction and operation play significant roles in facade applications.

These findings emphasize the importance of optimal orientation and inclination in maximizing solar panel efficiency, yet also demonstrate the feasibility of utilizing less than ideal surfaces for solar applications in certain scenarios, with varying impacts on economic returns.

1.1.12. The European Global Radiation

The European Global Radiation

Across most of the European Union, about 75% of the annual global radiation is available during the summer months, spanning from April to September. However, due to the substantial variation in the optimal inclination angle during both winter and summer, factors such as the region's relief and geographical coordinates must be considered when determining the ideal solar panel orientation.

Numerous research studies across various European countries have delved into optimizing the pitch angle for solar panels. Investigations have been conducted in European Turkey [18,19], Romania [20], Austria and Germany [21], Italy [22], Greece [16], Cyprus [23], and



Spain [24] (source: DOI:10.1016/j.enconman.2005.05.015).

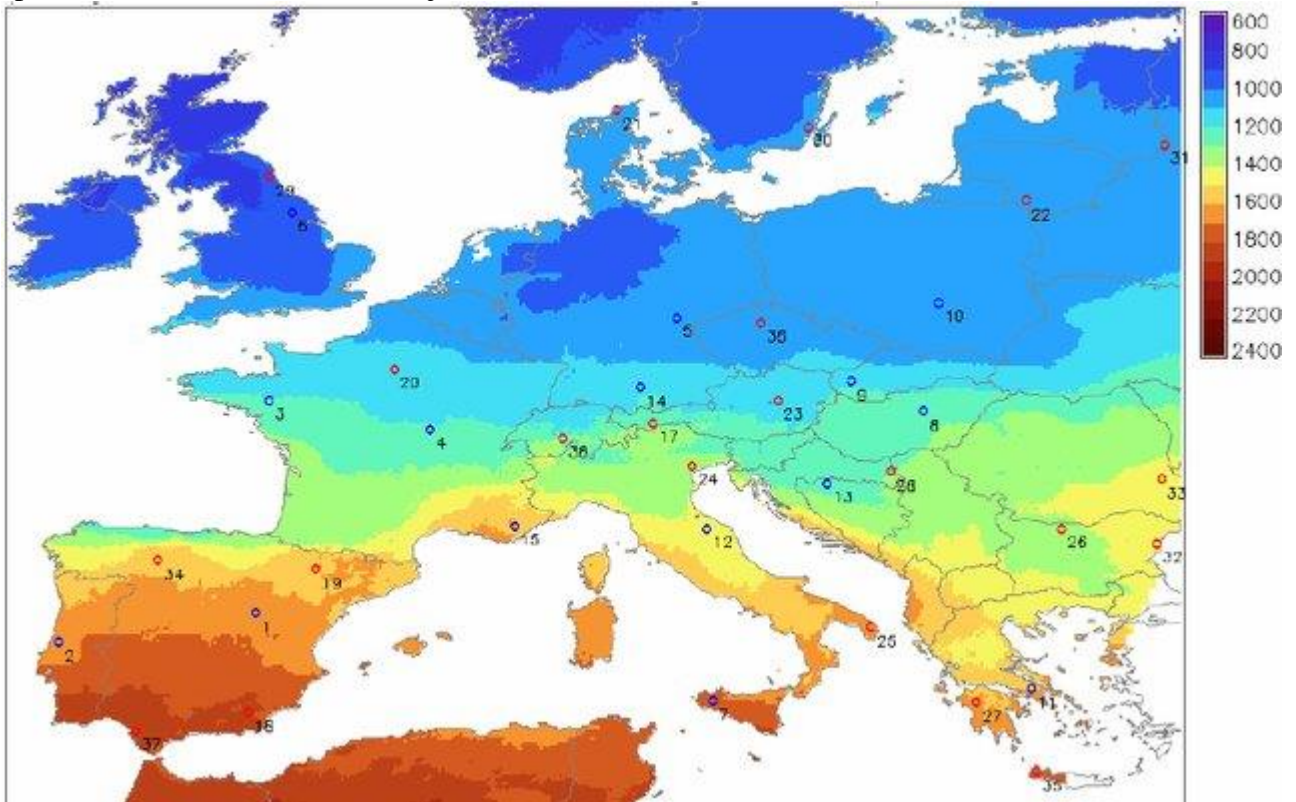

Figure: Yearly sum of global irradiation on horizontal surface – average of 6 databases: Meteonorm v.6, ESRA, PVGIS, NASA SSE v.6, Satel-Light and HelioClim-2 [kWh/m²] (Conference: 1st International Congress on Heating, Cooling and Buildings source: <https://www.researchgate.net/publication/236624704>)

To gauge the annual global radiation, data from six spatial databases (ESRA, PVGIS, Meteonorm, Satel-Light, HelioClim-2, and NASA SSE) were utilized and mapped accordingly.

Practically, optimizing the tilt angle and orientation of solar panels involves the use of sun trackers. Active solar trackers meticulously trace the Sun's path, ensuring optimal positioning of the solar modules. These tracking systems are designed to maximize the daily solar energy received by the PV modules. However, solar trackers possess mechanical components, which can be a drawback as their parts may malfunction, necessitating more rigorous maintenance compared to static solar panels. Additionally, trackers are slightly costlier, require energy to operate, and might not always be viable due to specific installation conditions.

1.1.13. What is surface albedo?



Co-funded by
the European Union

Funded by the European Union. Views and opinions expressed are however those of the author(s) only and do not necessarily reflect those of the European Union or the European Education and Culture Executive Agency (EACEA). Neither the European Union nor EACEA can be held responsible for them.

Surface albedo refers to the measurement of the diffuse reflection of solar radiation from the Earth's surface back into space upon incidence. This term, originating from the Latin word 'albus' meaning white, denotes the reflective quality of a surface. Albedo is a dimensionless quantity measured on a scale ranging from 0 to 1, where 0 signifies a surface that absorbs all incident radiation (like a black surface), and 1 represents a surface that reflects 100% of the received radiation back to space.

However, the concept of albedo, though seemingly straightforward, has complex implications. It's not a fixed property for a given surface but depends on various atmospheric factors and lighting conditions. Albedo values fluctuate across different temporal scales, including minutes, days, seasons, and even years.

Given the variability of albedo values, using a typical range of values can only offer an initial estimate (as indicated in the table).

Surface type	Typical value
Fresh asphalt	0.03 – 0.04
Open ocean	0.06
Conifer forest (summer)	0.08 – 0.15
Worn asphalt	0.12
Deciduous trees	0.15 – 0.18
Sand	0.15 – 0.45
Tundra	0.18 – 0.25
Agricultural crops	0.18 – 0.25
Bare soil	0.17
Green grass	0.20 – 0.25
Desert sand	0.30 – 0.40
Snow	0.40 – 0.90
Ocean ice	0.50 – 0.70
Fresh snow	0.80 – 0.90

Figure: Albedo measured on a clear day on January 2, 2011

at BSRN station Bondville, USA

The graph illustrates the characteristic pattern of the albedo function during a clear, sunny day (depicted by the purple line). Additionally, for comparison, the Global Horizontal Irradiance (GHI) graph is also displayed in the figure (indicated by the blue line).



These depictions reveal the variability of albedo over the course of a day and underscore how it changes in response to various environmental and lighting conditions.

1.2. Photovoltaic effect and principle of solar cells operation. 1.2.1. Photovoltaic effect and function of solar cells

Photovoltaic effect and function of solar cells

The photovoltaic effect is a fundamental process in which a photovoltaic (PV) cell or solar cell generates voltage or an electric current when exposed to sunlight. This effect serves as the underlying principle enabling solar panels to convert sunlight into electrical energy. The discovery of the photovoltaic effect is credited to Edmond Becquerel, who observed this phenomenon in 1839 during experiments with wet cells. He noticed that the voltage of the cell increased when its silver plates were exposed to sunlight.

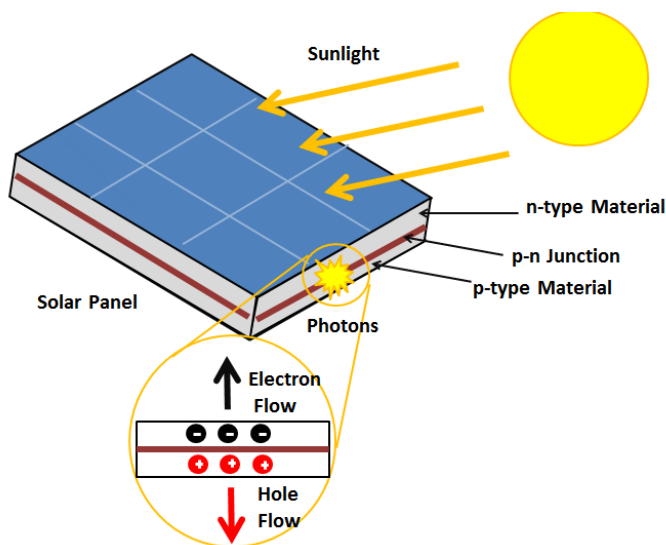

Figure: A diagram showing the photovoltaic effect, source: Created internally by a member of the Energy Education team. Adapted from: Ecogreen Electrical. (August 14, 2015). Solar PV Systems [Online]. Available: <http://www.ecogreenelectrical.com/solar.htm>

Photovoltaics involves the direct conversion of light into electricity, achieved through the use of semiconductor materials like silicon, gallium arsenide, cadmium telluride, or copper indium diselenide. Among these, crystalline silicon solar cells are the most widely used.

Solar cells are constructed with multiple layers of semiconductor materials. When sunlight strikes these materials, photons are absorbed, generating electrons and creating an electric field across the layers. This electric field causes the flow of electrons, generating a direct current (DC) within the cell, which can be collected and used as electrical energy.

The practical application of the photovoltaic effect has led to the development of solar panels and the widespread utilization of solar energy as a clean and renewable power source.

1.2.2. Functional principle of a solar cell - intrinsic conduction

The functional principle of a crystalline silicon solar cell revolves around the behavior of silicon atoms in a crystal lattice and their interaction with light, resulting in the generation of electron-hole pairs. Silicon, used in solar cells, needs to be highly pure and possess a high-quality crystal structure.

In a silicon crystal lattice, each silicon atom has four valence electrons in its outer shell. To achieve stability, each silicon atom forms electron pair bonds with its neighboring atoms, sharing two electrons to create a stable crystal structure. This bonding arrangement forms the basis of the stable electron configuration for silicon, resembling the structure of noble gases, which have eight outer electrons.

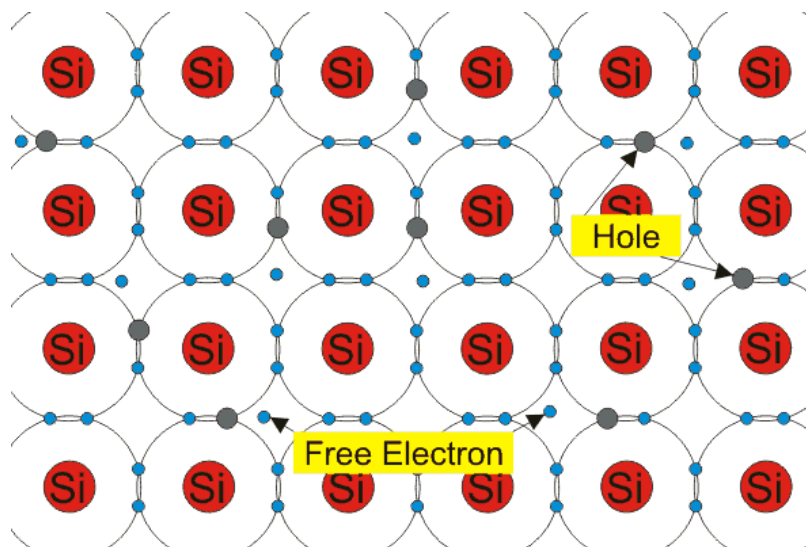

Figure: Intrinsic Silicon at Room Temperature,

source: <https://www.electrical4u.com/intrinsic-silicon-and-extrinsic-silicon/>

When exposed to light or heat, an electron within the crystal lattice can gain enough energy to break free from its covalent bond, leaving behind an empty space or "hole" in the lattice. This phenomenon, known as intrinsic conduction, generates an equal number of free

electrons and holes in the silicon crystal. At room temperature (around 300 Kelvin), the energy required for electrons to move from the valence band to the conduction band, referred to as the band gap energy, is approximately 1.2 electron volts (eV) for silicon.

Intrinsic silicon behaves as a semiconductor at room temperature, allowing some of its valence electrons to transition to the conduction band, creating equal concentrations of free electrons and holes. At a certain equilibrium temperature, while new electron-hole pairs are continually generated due to thermal energy, an equal number of pairs recombine, maintaining a stable concentration of electron-hole pairs within the silicon lattice. This equilibrium condition establishes that the concentration of free electrons, holes (p), and intrinsic charge carrier concentration (n_i) are approximately equal, denoted as n_i , where $n_i = n = p$.

1.2.3. The functional principle of a solar cell – doping

When intrinsic silicon is intentionally doped with specific controlled amounts of dopants, it transitions into extrinsic silicon, altering its conductive properties. Doping with certain elements from group V of the periodic table—such as phosphorus (P), arsenic (As), antimony (Sb), and bismuth (Bi)—transforms the silicon into an n-type semiconductor.

These group V elements have five valence electrons, one more than silicon, and are known as donor atoms. Upon replacing a silicon atom within the crystal lattice, the additional valence electron of the dopant atom forms covalent bonds with neighboring atoms, while the extra fifth electron remains loosely bound to the atom. This loosely attached electron can easily break free from the atom as a free electron, contributing to the silicon crystal's conductivity. The energy required to release this fifth electron is approximately 0.05 electron volts (eV). Due to the contribution of free electrons, this type of impurity is referred to as a donor impurity, leading to the silicon being labeled as n-type, signifying the presence of negatively charged electrons.



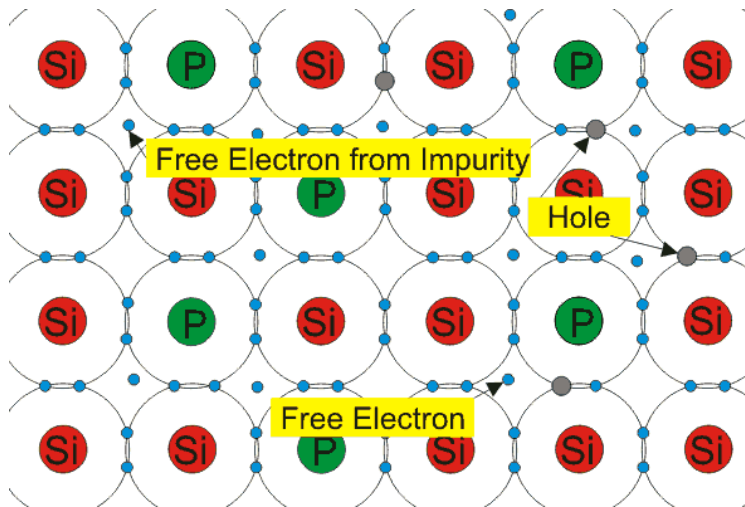

Figure: n-type semiconductor doping of phosphorus (P)- group V elements,
source: <https://www.electrical4u.com/intrinsic-silicon-and-extrinsic-silicon/>

In n-type silicon, the Fermi energy level moves closer to the conduction band compared to intrinsic silicon. Consequently, the concentration of free electrons increases above the intrinsic electron concentration. Meanwhile, the concentration of holes decreases compared to the intrinsic concentration of holes due to a higher likelihood of recombination resulting from the larger concentration of free electrons. Electrons become the majority charge carriers in n-type silicon.

1.2.3. The functional principle of a solar cell – doping

When a small quantity of group III elements is introduced to an intrinsic semiconductor crystal, they replace silicon atoms within the crystal lattice. Group III elements such as aluminum (Al), boron (B), and indium (In) possess three valence electrons. These three valence electrons form covalent bonds with neighboring atoms, creating a vacancy or a hole in the crystal lattice. These impurity atoms are referred to as acceptors. Consequently, the semiconductor is referred to as a p-type semiconductor as the holes are considered to be positively charged carriers.

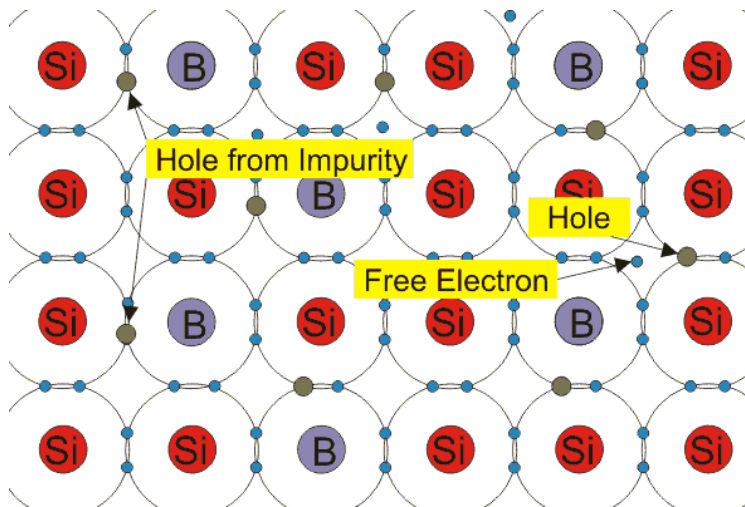

Figure: n-type silicon doping element B from group III

In p-type semiconductors, the Fermi energy level shifts downward, approaching closer to the valence band compared to intrinsic silicon. This shift leads to an increase in the concentration of holes and a decrease in the concentration of electrons compared to the intrinsic carrier concentration of silicon. In p-type semiconductors, free electrons find an abundance of holes within the crystal. Holes become the majority charge carriers in p-type semiconductors.

1.2.3. The functional principle of a solar cell – doping

It's correct that in doped semiconductors, the impurity atoms introduce additional energy levels within the band gap, causing impurity conduction. However, for *n*- or *p*-doped materials separately, the free charges don't have a predetermined direction in their motion.

When an electron moves from the valence band to the conduction band due to thermal excitation, it creates free carriers in both bands: electrons in the conduction band and holes in the valence band. The concentration of these carriers is known as the intrinsic carrier concentration. In a pure or intrinsic silicon crystal, the number of holes (*p*) and electrons are equal to each other, and they both equal the intrinsic carrier concentration, denoted as n_i . Therefore, $n = p = n_i$.

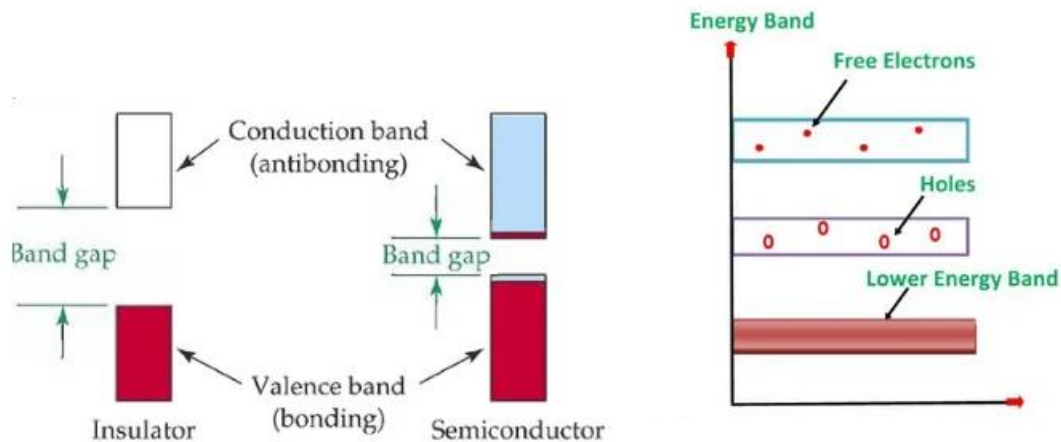

Figure: Band structure of the

semiconductor, source: <https://www.electrical4u.com/intrinsic-silicon-and-extrinsic-silicon/>

The count of these carriers relies on the band gap energy. For silicon, the band gap energy is 1.2 eV at 298 K. The intrinsic carrier concentration in silicon increases with temperature. The equation for intrinsic carrier concentration in silicon is:

$$n_i = BT^{3/2} \cdot e^{-E_g/(2kT)}$$

where:

T - temperature in absolute scale (Kelvin)

B - a constant

E_g - band gap energy

k - Boltzmann's constant

At 300 °K, the intrinsic carrier concentration is approximately $1.01 \times 10^{10} \text{ cm}^{-3}$. However, previously accepted values were around $1.5 \times 10^{10} \text{ cm}^{-3}$.

1.2.4. What is a PN Junction?

A PN junction is formed by combining a p-type semiconductor (with excess holes) and an n-type semiconductor (with excess electrons) in a single crystal of semiconductor material. This junction is the foundation of semiconductor devices like diodes and transistors.

When these two types of semiconductors are joined, electrons from the n-type region migrate to the p-type region due to diffusion, combining with holes. This migration creates a layer of negative ions in the p-type region and a layer of positive ions in the n-type region near the junction.

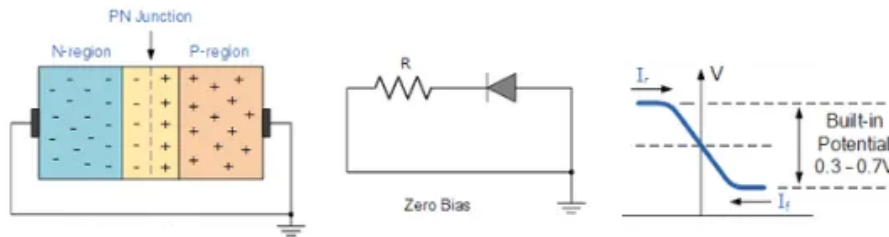

Figure: pn-переход, source: <https://www.electrical4u.com/pn-junction-theory-behind-pn-junction/>

As this process continues, a depletion region forms at the junction. This depletion region lacks free electrons and holes because they've combined. The combination of negative and positive ions creates an electrical potential across the junction, forming a potential barrier or a barrier potential. This potential barrier's magnitude depends on the material, doping levels, and temperature. For germanium, the barrier potential at 25°C is around 0.3 volts, while for silicon, it's about 0.7 volts.

This depletion region is extremely thin, usually just a few micrometers in width. Despite its small size, it plays a crucial role in semiconductor behavior, allowing the PN junction to function as a diode or other semiconductor device by controlling the flow of current.

1.2.5. The photovoltaic effect

When the PN semiconductor (solar cell) is exposed to light, photons are absorbed by the electrons.

Some of the absorbed photons will have energy greater than the energy gap between the valence and conduction bands of the silicon atoms. Consequently, some valence electrons in the covalent bond become excited and dislodge from the bond, leaving behind a hole. This process generates electron-hole pairs in the crystal due to incident light. The holes in these light-generated electron-hole pairs in the n-type side have a high probability of recombining with numerous electrons (majority carriers). Therefore, solar cells are specifically designed to prevent the light-generated electrons or holes from recombining with majority carrier



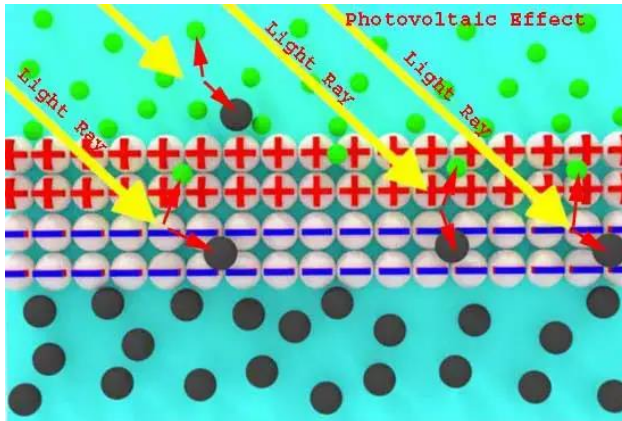

Figure: The photovoltaic effect, source: <https://www.electrical4u.com/what-is-photovoltaic-effect/>

The semiconductor (silicon) is so doped that the p-n junction forms in very close vicinity of exposed surface of the cell. If an electron hole pair is created within one minority carrier diffusion length, of the junction, the electrons of electron-hole pair will drift toward n-type region and hole of the pair will swept to p region due to in influence of electric field of the junction and hence on the average, it will contribute to current flow in an external circuit.

This entire process is referred to as the **photovoltaic** effect. The diffusion of charge carriers up to the electrical contacts causes a voltag

This entire process is referred to as the **photovoltaic** effect. The diffusion of charge carriers up to the electrical contacts causes a voltag

1.2.6. The characteristics of photovoltaic cells

The classic crystalline silicon solar cell comprises two differently doped silicon layers. The layer facing the sunlight is negatively doped with phosphorus, while the layer below is positively doped with boron. This setup creates an electric field at the boundary layer, leading to the separation of charges (electrons and holes) released by sunlight. To draw current from the solar cell, metallic contacts are applied to the front and back using the screen printing technique. A contact layer, usually aluminum or silver paste, can be applied over the entire back surface. On the front, contacts are typically applied in the form of a thin **grid** or tree structure to maintain translucency. Reducing light reflection is achieved by depositing a thin layer (anti-reflective layer) of silicon nitride or titanium dioxide on the front of the solar cell.

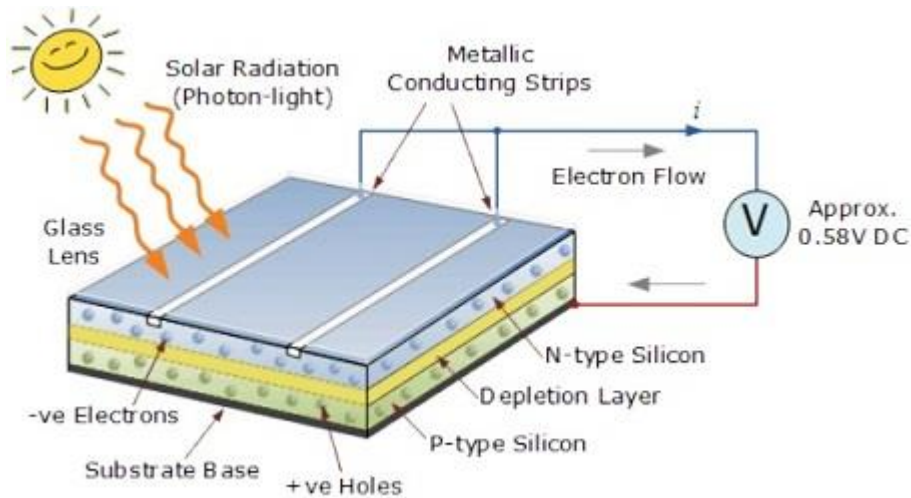

Figure: Structure and function of a crystalline solar cell

source: <https://electricalengineering123.com/solar-cell-construction-working-principle/>

Solar Cell Construction Diagram and Working Principle

The terms 'Emitter n-type silicon' and 'Base p-type silicon' are historical but commonly used to illustrate the functionality of layers in a p-n junction. Light enters the emitter first, typically thin to maintain a near depletion region where light absorption is strong. The base is usually thicker to absorb most of the light.

Working Principle of Solar Cell

When sunlight strikes the cell, photons are absorbed, some possessing energy greater than the energy gap between the valence and conduction bands in the semiconductor crystal. This causes a valence electron to receive energy from a photon, becoming excited and creating an electron-hole pair. These are known as light-generated electrons and holes. Light-generated electrons near the p-n junction move to the n-type side due to the electrostatic field force across the junction, while light-generated holes near the junction move to the p-type side.

The incident light disturbs the thermal equilibrium state of the transition, enabling free electrons and depletion holes to swiftly cross the junction. However, once newly created free electrons reach the n-type side, they cannot further cross the junction due to its barrier potential. Similarly, newly created holes reaching the p-type side face the same barrier potential and cannot cross further. This accumulation results in higher electron concentration on the n-type side and a higher hole concentration on the p-type side, causing the p-n junction to behave like a small battery. This establishes a potential difference or photovoltage between the two sides. Connecting these sides in an external circuit leads to current flow from the positive to the negative terminal of the solar cell.



Materials Used in Solar Cell

The materials which are used for this purpose must have band gap close to 1.5eV. Commonly used materials are: Silicon ; GaAs; CdTe; CuInSe₂

Criteria for Materials to be Used in Solar Cell

The material must have a band gap ranging from 1 eV to 1.8 eV, high optical absorption, high electrical conductivity, and be abundant and cost-effective.

The basic steps in the operation of a solar cell are:

Generation of light-generated carriers. Collection of these carriers to generate current. Creation of a significant voltage across the solar cell. Dissipation of power in the load and parasitic resistances."

1.2.7. V-I Characteristics of photovoltaic cells

Characteristics of photovoltaic cells

The effect of light on the current-voltage characteristics of a p -n junction.

The IV curve of a solar cell is the superposition of the IV curve of the solar cell diode in the dark with the light-generated current. The light has the effect of shifting the IV curve down into the fourth quadrant where power can be extracted from the diode. Illuminating a cell adds to the normal "dark" currents in the diode so that the diode law becomes:

$$I = I_0 \left[\exp \left(\frac{qV}{nkT} \right) - 1 \right] - I_L$$

where I_L = light generated current.



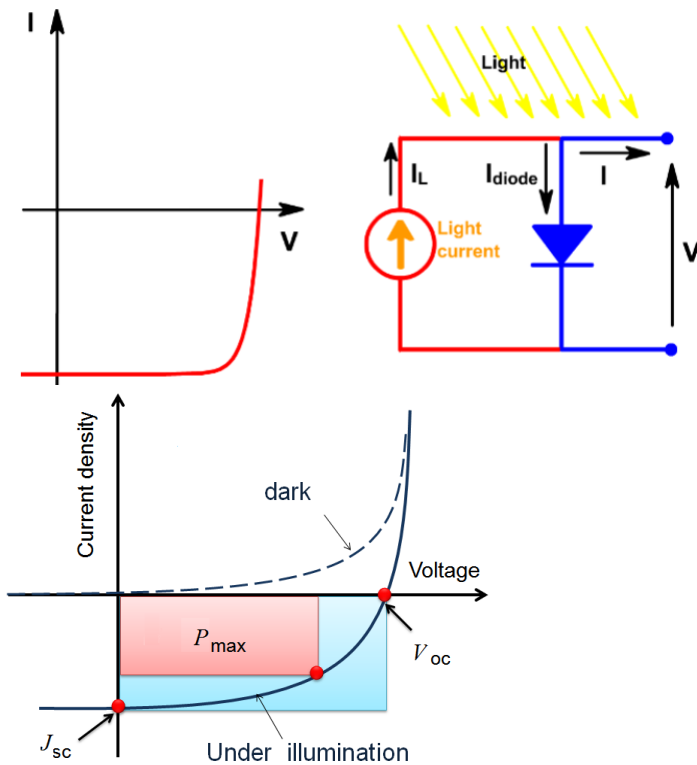

Figure: J-V characteristic of a typical solar cell in the dark (dashed line) and under illumination (solid line). Typical solar cell parameters such as short-circuit current density J_{sc} , open-circuit voltage V_{oc} , and the maximum power point P_m are illustrated in the graph source: https://www.researchgate.net/figure/J-V-characteristic-of-a-typical-solar-cell-in-the-dark-dashed-line-and-under_fig37_283662836

Several important parameters that are used to characterize solar cells are indicated in the graph below.

The short circuit current (ISC), the open circuit voltage (VOC),

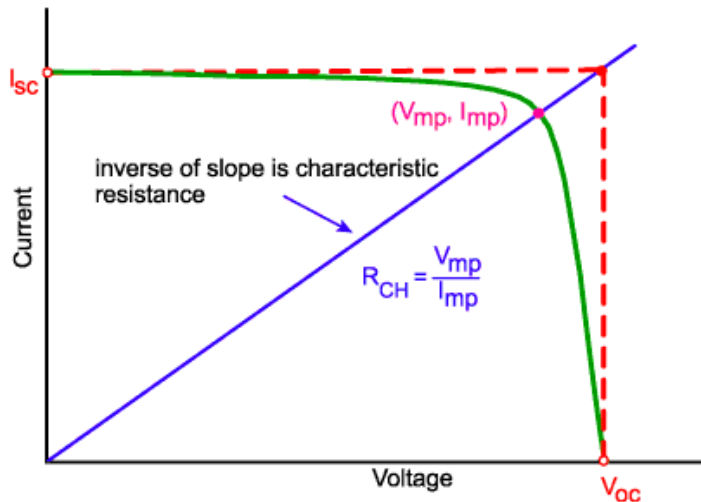

Figure: The characteristic resistance of a solar cell, source: <https://www.pveducation.org/pvcdrom/solar-cell-operation/characteristic-resistance>

The maximum current that a solar cell can deliver without harming its own construction. It is measured by short circuiting the terminals of the cell at most optimized condition of the cell for producing maximum output. The term optimized condition I used because for fixed exposed cell surface the rate of production of current in a solar cell also depends upon the intensity of light and the angle at which the light falls on the cell. As the current production also depends upon the surface area of the cell exposed to light, it is better to express maximum current density instead maximum current. Maximum current density or short circuit current density rating is nothing but ratio of maximum or short circuit current to exposed surface area of the cell.

$$J_{sc} = \frac{I_{sc}}{A}$$

Where, I_{sc} is short circuit current, J_{sc} maximum current density and A is the area of solar cell

1.2.7. V-I Characteristics of photovoltaic cells

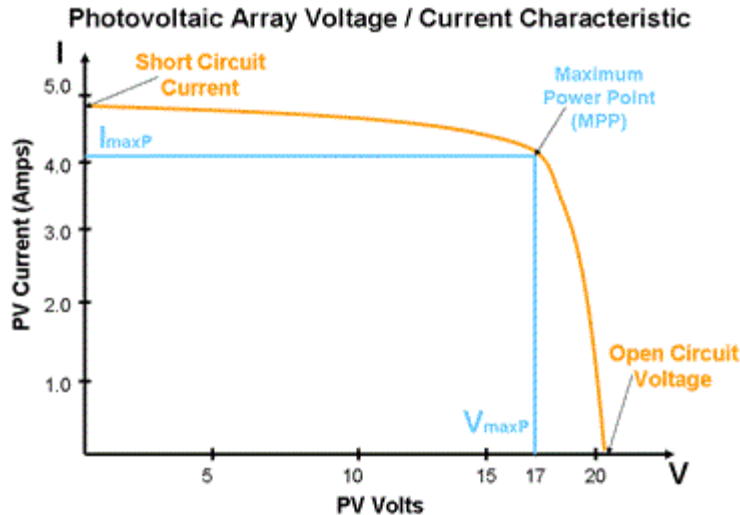

Figure: V-I Characteristics of a Photovoltaic Cell

Open Circuit Voltage of Solar Cell

It is measured by measuring voltage across the terminals of the cell when no load is connected to the cell. This voltage depends upon the techniques of manufacturing and temperature but not fairly on the intensity of light and area of exposed surface. Normally open circuit voltage of solar cell nearly equal to 0.5 to 0.6 volt. It is normally denoted by V_{oc} .

Maximum Power Point of Solar Cell

The maximum electrical power one solar cell can deliver at its standard test condition. If we draw the v-i characteristics of a solar cell maximum power will occur at the bend point of the characteristic curve. It is shown in the V-I characteristics of solar cell by P_m .

Current at Maximum Power Point

The current at which maximum power occurs. Current at Maximum Power Point is shown in the v-i characteristics of solar cell by I_m .

Voltage at Maximum Power Point

The voltage at which maximum power occurs. Voltage at Maximum Power Point is shown in the v-i characteristics of solar cell by V_m .

Fill Factor of Solar Cell

The ratio between product of current and voltage at maximum power point to the product of short circuit current and open circuit voltage of the **solar cell**.

$$\text{Fill Factor} = \frac{P_m}{I_{sc} \times V_{oc}}$$

Efficiency of Solar Cell

It is defined as the ratio of maximum electrical power output to the radiation power input to the cell and it is expressed in percentage. It is considered that the radiation power on the earth is about 1000 watt/square metre hence if the exposed surface area of the cell is A then total radiation power on the cell will be 1000 A watts. Hence the efficiency of a solar cell maybe expressed as

$$\text{Efficiency}(\eta) = \frac{P_m}{P_{in}} \approx \frac{P_m}{1000A}$$

1.3. Types of technologies for creating PV cells.

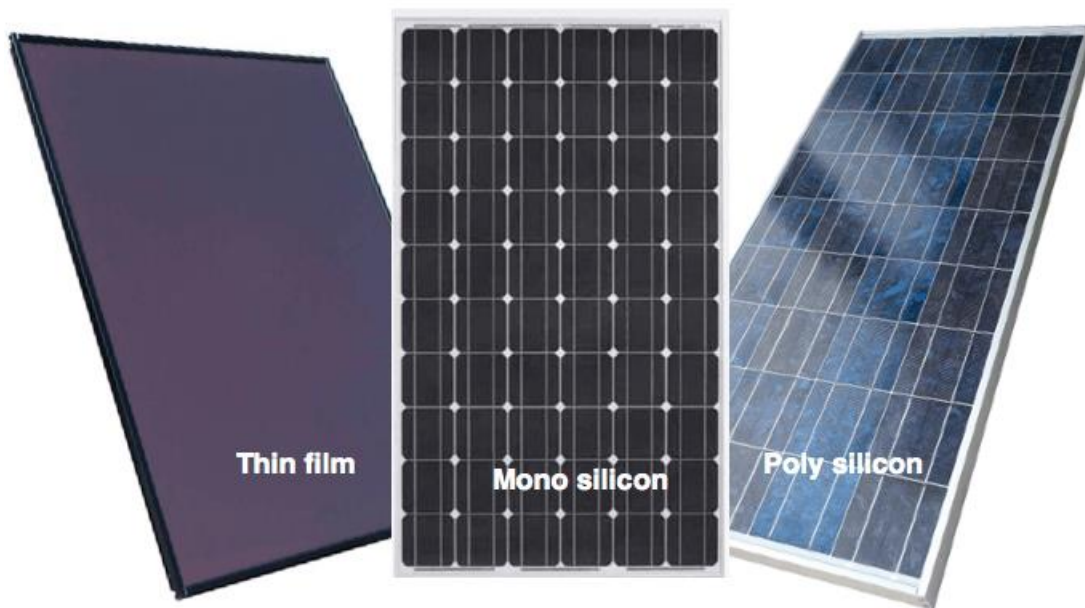

1.3.1. Types of Solar Cells.

The creation of the first photovoltaic cell took place at Bell Laboratories in the 1950s. Since then, numerous photovoltaic cells have been developed, with the number continuing to grow. As various laboratories and researchers work on diverse types of photovoltaic cells, we anticipate witnessing the emergence of newer and more advanced technologies.

Solar cells can typically be categorized into three main types: crystalline silicon solar cells, thin-film solar cells, and third-generation solar cells. The first-generation technology, crystalline silicon solar cells, made its debut in 1954. Following this, the second-generation technology, thin-film solar cells, emerged 26 years later. The third-generation solar cell, which is still emerging and not fully commercialized, represents the latest advancement.

Solar cell technologies are grouped into three categories. First, crystalline silicon cells are soldered together in modules as wafers, approximately 200 micrometers thick. Second, thin-film cells, comprised of cell layers only a few micrometers thick, are typically deposited on the front glass of the module. Third, nanostructured cells are making their way into the market. These cells consist of nanometer-sized complete solar cells interconnected in modules. Currently, crystalline silicon solar cells dominate the market with a share of over 90%. Nevertheless, a significant increase in the share of thin-film technologies is anticipated in the near future, with an expected market share of around 30% in the medium term. Nanostructured cells are also projected to achieve considerable market shares in the long term.

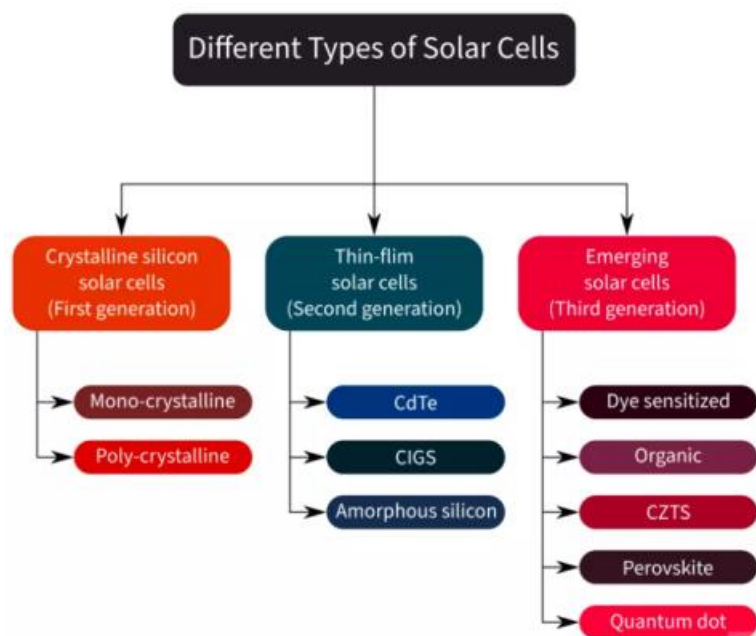

Figure: Different types of solar cells: crystalline silicon (mono, poly), thin-film (CdTe, CIGS, a-Si), and emerging solar cells

source: <https://solarsena.com/>

Generations of solar cells

Solar cells are usually categorized into 3 generations:

First-generation solar cells are primarily based on silicon technology, offering moderate performance with an efficiency of 15-20%. They are the most commonly used cells today. **Second-generation** solar cells rely on amorphous silicon, CIGS, or CdTe, demonstrating lower efficiency. **Third-generation** solar cells employ organic materials and have the potential to achieve efficiencies above 30%. Recent research on perovskite solar cells has yielded efficiencies exceeding 20%.

1.3.2. The crystalline Silicon Solar Cells

Crystalline silicon solar cells, classified as first-generation photovoltaic cells, consist of silicon crystals, also known as crystalline silicon (c-Si). Crystalline silicon is a fundamental material in semiconductor technology, including the photovoltaic system.

As of 2016, these solar cells held over 80% of the photovoltaic market due to their high efficiency. Monocrystalline silicon refers to single crystal silicon, representing a homogeneous material with consistent electric, thermal, and crystal properties across the cell. There are no defects in monocrystalline silicon.

This uniformity makes mono c-Si superior in electrical performance compared to polycrystalline silicon (poly c-Si). Consequently, monocrystalline solar cells exhibit higher efficiency than polycrystalline ones. Laboratory-scale efficiency is reported to be around 25%, while at the production-scale, it ranges from 20% to 22%.

However, one significant drawback of monocrystalline silicon cells is their relatively higher cost compared to polycrystalline cells. The manufacturing process of monocrystalline cells is less efficient and generates material wastage. Physically, monocrystalline cells are identifiable by their single-piece structure and black coloration. Their clipped corners give them an octagonal shape, providing a more aesthetic and premium appearance.



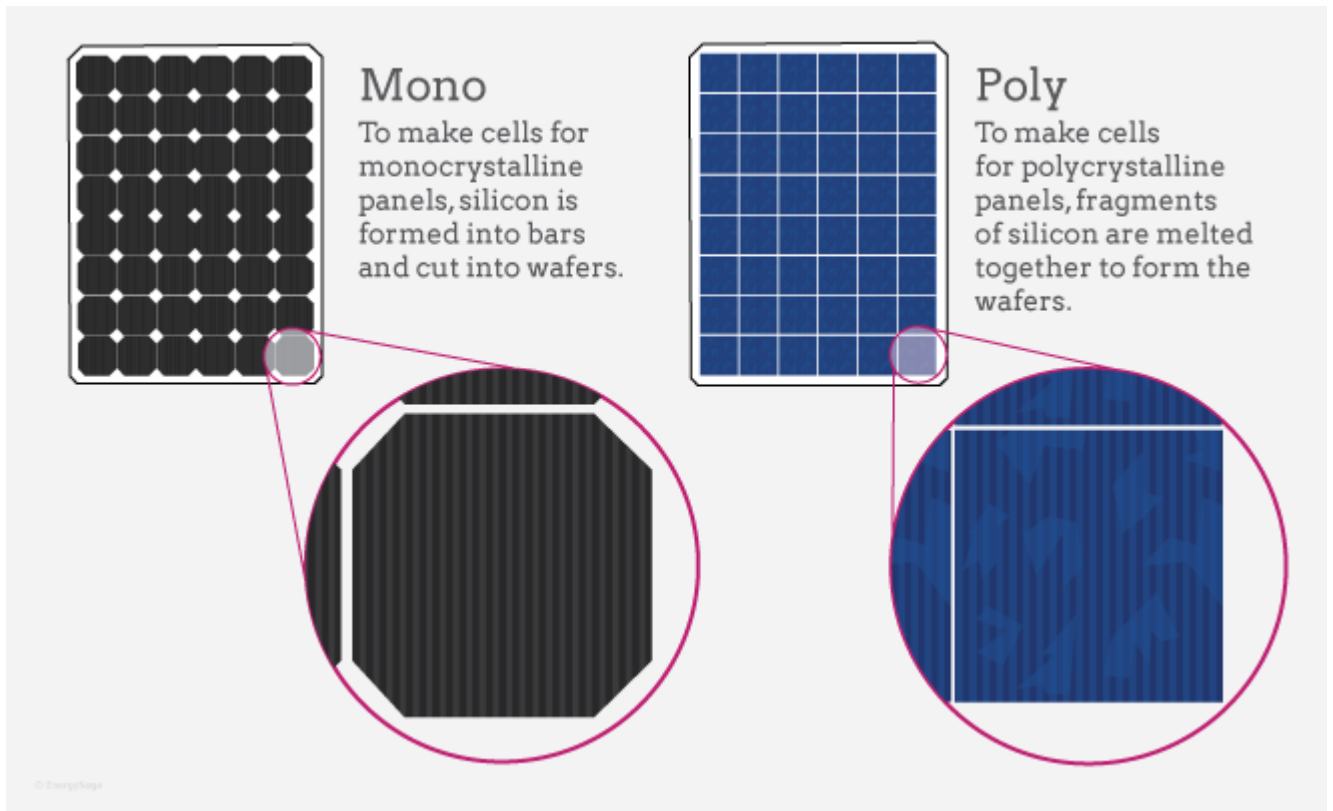

Figure: Monocrystalline silicon solar cells, source: <https://ases.org/monocrystalline-vs-polycrystalline-solar-panels/>

Polycrystalline Silicon Solar Cells

In contrast to monocrystalline silicon, polycrystalline silicon is composed of multiple small crystallites, creating a non-homogeneous material with discontinuities in electrical, thermal, and crystal properties.

Due to the crystal structure defects, poly c-Si solar cells demonstrate lower efficiency than mono c-Si cells. The highest laboratory-scale efficiency reported is around 22%, whereas in production, it falls between 18% and 20%.

Despite their lower efficiency, polycrystalline silicon cells are more cost-effective than monocrystalline ones. Additionally, the production process for poly c-Si cells is simpler and boasts a higher production rate compared to mono c-Si.

In summary, there are two types of crystalline silicon solar cells: monocrystalline silicon (mono c-Si) and polycrystalline silicon (poly c-Si).



1.3.3. Thin-film solar cells

The text seems well-structured and mostly free of major errors. Here's a refined version with some adjustments for clarity and coherence:

"Thin-film solar cells represent newer photovoltaic technology, comprised of one or multiple thin layers of photovoltaic materials placed on a substrate. Their primary advantage over traditional crystalline silicon cells is cost-effectiveness.

One significant benefit is their flexibility. These cells have nanometer-level film thickness, making them pliable. However, rigid thin-film cells can also be manufactured when a rigid substrate is used.

The common types of thin-film solar cells include cadmium telluride (CdTe), copper indium gallium selenide (CIGS), and amorphous thin-film silicon (a-Si).

Similar to other solar panels, thin-film panels convert light energy into electrical energy through the photovoltaic effect. Unlike traditional systems, thin-film solar panels are lighter and more flexible second-generation cells, composed of multiple thin layers of photovoltaic materials.

These layers are approximately 300 to 350 times thinner than standard silicon, making this technology ideal for portable devices. Each cell consists of three main components: photovoltaic material, a conductive sheet, and a protective layer.

Thin-film solar panels differ from traditional monocrystalline and polycrystalline panels in the materials used during production and in efficiency, but we'll explore this in more detail later on.





Figure: Thin-film solar cells,

source: https://www.researchgate.net/publication/283742145_Arcing_in_Very_Large_Area_Plasma-Enhanced_Chemical_Vapour_Deposition_Reactors

How Efficient Are Thin-Film Panels?

While thin-film solar panels are more economical than monocrystalline and polycrystalline silicon panels, they tend to be less efficient with lower power capacity. Efficiency has been a significant challenge for these panels and varies among different types of thin-film photovoltaic panels, albeit showing improvements over time.

In 2015, Solar Frontier, the world's largest copper indium selenium (CIS) solar energy provider, achieved a 22.3% conversion efficiency, marking a 0.6% increase over the industry's previous record. However, most thin-film solar substrates typically range from 6% to 18% efficiency.



Although not yet available to consumers, recent solar advancements report researchers at the Fraunhofer Institute for Solar Energy Systems achieving a record 68.9% efficiency of gallium arsenide (GaAs) panels under laser light. Here are the efficiency ratings for the four most common types of thin-film solar panels:

Amorphous silicon (a-Si) panels: 7% efficient

Cadmium telluride (CdTe) panels: 9% to 15% efficient, with the highest lab test achieving 18.3%

Copper indium gallium diselenide (CIGS) panels: 12% to 14% efficient, with tests in Germany reaching 23%

Organic photovoltaic (OPV) panels: 18.2% efficient.

1.3.4. Cadmium Telluride (CdTe) cells

While amorphous silicon solar cells are well-developed, cadmium telluride (CdTe) panels are the most prevalent type of thin-film modules available. They stand as the second most widely used type globally, following crystalline silicon (c-Si) cells.

As the name implies, these cells are crafted using cadmium telluride, a compound highly efficient in capturing and converting sunlight into energy. CdTe panels are less expensive than standard silicon thin-film cells and boast the quickest payback time among thin-film panels currently in the market.

Another advantage of cadmium telluride panels is their minimal carbon footprint compared to other film-thin panels available to consumers. However, a significant drawback lies in these solar panels containing a substantial amount of cadmium, a toxic element. Special precautions must be taken in handling this component.

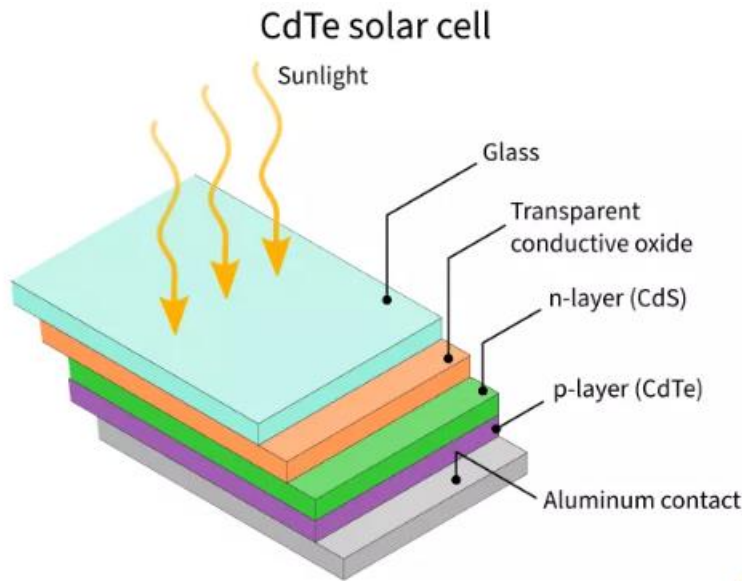

Figure: A cadmium telluride (CdTe) solar cell is thin-film technology formed by depositing nanolayers on a substrate. source: <https://solarsena.com/>

Throughout the manufacturing process and while in use to generate electricity on rooftops, these panels pose no harm to humans or the environment. Nevertheless, the disposal of old panels remains a significant concern. Furthermore, telluride is a scarce element, which poses challenges in mass-producing this technology.

PROS OF CADMIUM TELLURIDE	CONS OF CADMIUM TELLURIDE THIN-FILM SOLA
+ Absorbing layers are great at converting energy	– Large amounts of toxic element cadmium
+ Less expensive and quickest payback time compared to standard cells	– Telluride is a difficult element to find, component in manufacturing
+ Smallest carbon footprint	

1.3.5. Copper Indium Gallium Selenide

A Copper Indium Gallium Selenide solar cell, abbreviated as CIGS or CIS (for gallium-free variants), utilizes an absorber made of copper, indium, gallium, and selenide. These materials are deposited as a thin layer onto glass or plastic backing, accompanied by electrodes on the front and back to collect current. Due to its high absorption coefficient, this material requires a thinner film compared to other semiconductors, as it strongly absorbs sunlight.





Figure: Thin CIGSe (Cu(In,Ga)(Se)₂) solar cell, produced at Solarion AG. Substate: Polyimid. source: https://en.wikipedia.org/wiki/Copper_indium_gallium_selenide_solar_cell

This cell type exhibits promising efficiency owing to its high absorption coefficient. Laboratory tests have shown efficiencies surpassing 20%. However, on a commercial scale, efficiencies typically range between 12 to 14%.

CIGS layers possess flexibility, allowing their deposition on flexible substrates. While high-temperature deposition techniques are typically used, recent advancements in low-temperature deposition have narrowed the performance gap between cells deposited on glass and flexible substrates. CIGS outperforms polysilicon at the cell level, yet its module efficiency remains lower due to less mature scaling.

These thin layers, supported by flexible backings, offer versatility that traditional solar technology lacks. Despite their efficiency, many CIGS panels contain cadmium, a toxic element also found in cadmium telluride (CdTe) panels. However, some current CIGS cells have substituted this chemical for eco-friendlier alternatives like zinc oxides.

Nevertheless, the main setback lies in their cost. CIGS panels remain expensive to produce, posing challenges in competing with CdTe or silicon solar panels.

PROS OF CIGS THIN-FILM SOLAR PANELS	CONS OF CIGS THIN-FILM SOLAR PANELS
+ Very efficient film-thin panel	– Very expensive to produce
+ Some panels are using zinc in place of cadmium	– Most contain toxic chemical cadmium
+ High efficiency ratings	



1.3.6. Amorphous silicon solar cells

Amorphous silicon (a-Si) stands as a non-crystalline, allotropic form of silicon and remains the most well-developed thin-film technology to date. This thin-film silicon presents an alternative to conventional wafer (or bulk) crystalline silicon. While chalcogenide-based CdTe and CIS thin-film cells have seen successful development in laboratories, there's still industry interest in silicon-based thin-film cells. Silicon-based devices encounter fewer issues compared to their CdTe and CIS counterparts, such as the toxicity and humidity problems with CdTe cells and the low manufacturing yields of CIS due to material complexity.

a-Si serves as an attractive solar cell material due to its abundance and non-toxic nature. It operates at low processing temperatures, facilitating scalable production on flexible, low-cost substrates with minimal silicon material required. With a bandgap of 1.7 eV, amorphous silicon absorbs a broad light spectrum, including infrared and even some ultraviolet, performing well in weak light conditions. This capability enables the cell to generate power during early mornings, late afternoons, as well as on cloudy and rainy days. In contrast, crystalline silicon cells are notably less efficient in diffuse and indirect daylight.

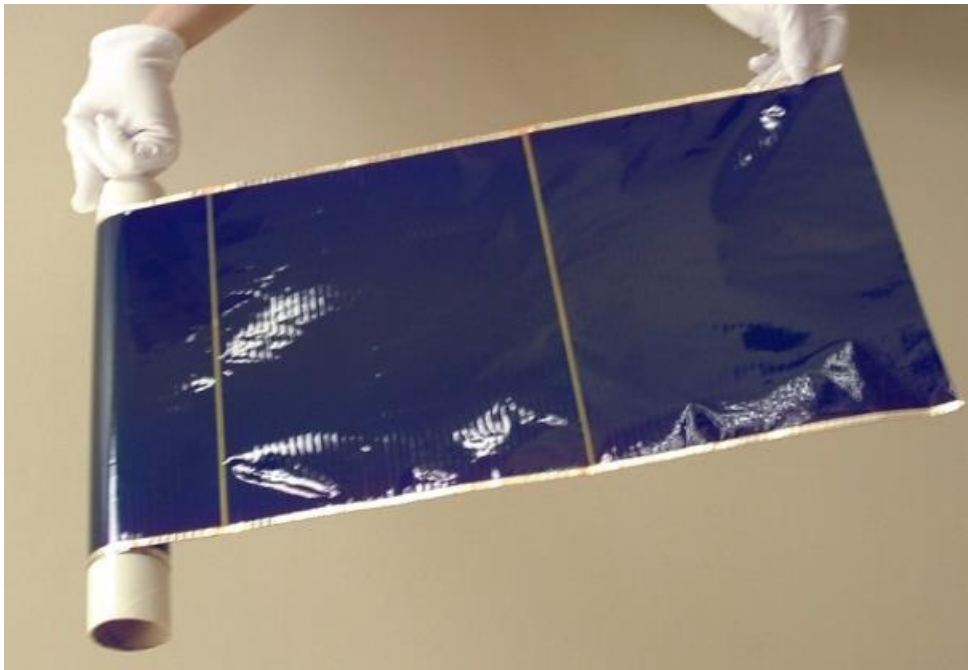

Figure: Aerospace Product-Flexible Thin-Film Solar PV-United Solar Ovonic -

NASA, source:



Co-funded by
the European Union

Funded by the European Union. Views and opinions expressed are however those of the author(s) only and do not necessarily reflect those of the European Union or the European Education and Culture Executive Agency (EACEA). Neither the European Union nor EACEA can be held responsible for them.

However, the efficiency of an a-Si cell experiences a significant drop of about 10 to 30 percent during the initial six months of operation. This is known as the Staebler-Wronski effect (SWE), a common decline in electrical output due to changes in photoconductivity and dark conductivity caused by prolonged exposure to sunlight. While this degradation is reversible upon annealing at or above 150 °C, conventional c-Si solar cells don't exhibit this effect initially.

1.3.7. Emerging solar cells

Emerging solar cells represent third-generation technology primarily found in research laboratories due to their developmental stage. Despite their growing attention, none of these cells has exhibited commercial efficiency comparable to crystalline silicon cells. They offer potential for cost-effective production using the roll-to-roll method.

The most popular emerging solar cells include dye-sensitized, organic, CZTS, perovskite, and quantum dots.

Dye-Sensitized, Organic Solar Cells

Dye-sensitized solar cells (DSSCs) stand as a unique type of low-cost photovoltaic cell effectively converting visible light into electrical energy. These cells mimic photosynthesis by absorbing natural light and hold promise for future energy needs due to their simple structure and materials.



Figure: Installation featuring dye-sensitized solar cells at the Swiss Tech convention center Image: EPFL/Alain Herzog

DSSCs are semi-transparent, flexible, and efficient thin-film solar cells that enable diverse applications beyond rigid silicon-based [photovoltaic](#) systems. They function even in low-light and overcast conditions, offer cheaper production, simplicity, compatibility with flexible substrates, and crucially, greater sunlight absorption per surface area than standard silicon-



based panels. In 2014, porphyrin dye-based liquid electrolyte DSSCs reported a power conversion efficiency (PCE) of up to 13%.

These cells are constructed with a semiconductor featuring nanoparticles of titanium dioxide (TiO₂) coated with a light-sensitive dye, encompassed by electrolytes, inserted between another electrolyte and a cathode. The transparent anode allows sunlight to pass through, exciting electrons that flow into the titanium dioxide. The electrolyte carries electrons back to the dye molecules. DSSCs divide the functions usually provided by silicon in traditional cell designs. The energy harvested by these cells powers electrical systems.

Dye-sensitized solar cells generate electricity even in low-light conditions, such as indoor lighting, and offer different colors and transparency due to structural design and varied dyes. Consequently, they find use in architecture, interior applications, electronic devices, and portable power systems.

However, DSSCs have drawbacks, including degradation from exposure to UV, temperature instability, and the expensive nature of ruthenium dyes. Moreover, the liquid state of the electrolyte solution can expand or contract with temperature changes, potentially damaging the cell.

1.3.8. Quantum dot solar cells

Quantum dot solar cells (QDSC) present a remarkable technological concept.

Quantum dots are semiconductor nanoparticles ranging in size from 2 to 20 nm, exhibiting unique behavior due to a phenomenon called quantum confinement. A part of the fourth-generation solar cells, quantum dot sensitized solar cells (QDSSC) resemble their forerunner, DSSC, consisting of a photoanode, cathode, and an electrolyte. However, they feature a photosensitizer layer composed of quantum dots like CdS, CdSe, CdTe, and graphene quantum dots (GQDs).

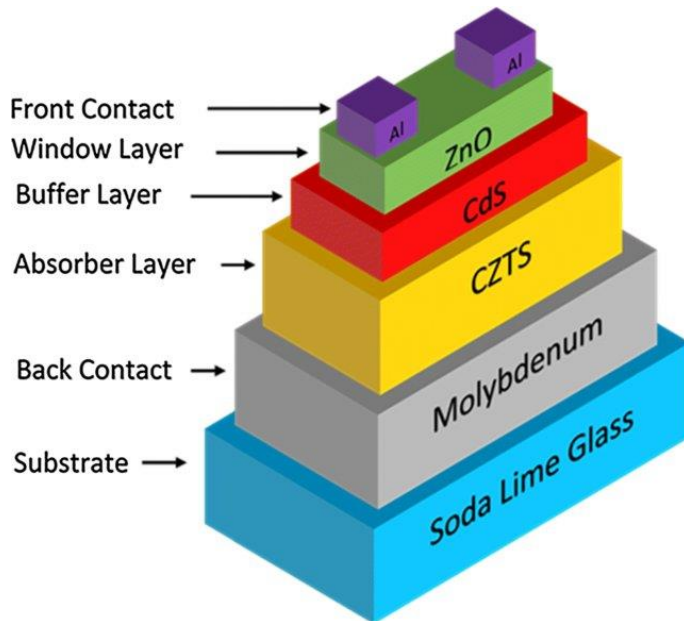

Figure: Basic structure of CZTS solar cell source: DOI: [10.1007/s11082-019-2180-6](https://doi.org/10.1007/s11082-019-2180-6)

A key advantage lies in the tunability of the bandgap of quantum dot cells based on the dot's size. This capability allows for designing cells capable of absorbing an entire spectrum of sunlight, including far-infrared rays—an impractical feat for conventional silicon cells. As of 2020, the highest known efficiency of these cells stands at 16.6%.

1.3.9. Organic solar cells

One of the most exciting advancements, potentially game-changing in the solar industry, is the emergence of the third generation of photovoltaic devices: organic solar cells.

Organic solar cells, also known as organic photovoltaic cells (OPV), represent the latest breakthrough in solar cell technology, garnering considerable attention from industry experts. Their appeal lies in their high performance, exceptional light absorption capacity, and remarkable versatility.



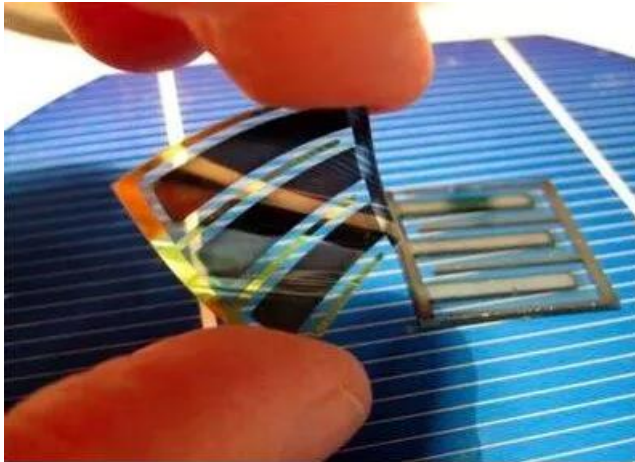

Figure: A prototype of a flexible organic cell, source: [University of Washington/cc](#)]

Both traditional silicon cells and organic solar cells follow the same photovoltaic process. The key difference lies in the semiconducting material used in each cell. While conventional solar cells utilize silicon, organic solar cells employ a carbon-based compound as their semiconductor.

Unlike traditional crystalline solar cells that use silicon as the absorber, organic solar cells feature a polymer or small molecule cell made from carbon-based materials and organic electronics. This construction results in an incredibly lightweight, flexible, and thinly-filmed solar cell. The design of organic solar cells makes them more durable and capable of covering a larger area compared to traditional counterparts.

Organic solar cells, although a relatively new innovation, exhibit promising potential for the industry. With their low-cost manufacturing processes and ongoing research and development, many industry experts consider them the future of the solar energy sector.

Pros of organic solar cells:

Flexible and lightweight structure: Organic solar cells are highly flexible and adaptable, allowing utilization across a broad area and adaptability to various substrates. Their flexible design also enhances durability compared to other solar modules. **Low manufacturing cost:** The soluble structure of organic molecules enables manufacturers to use a cost-effective and environmentally friendly roll-to-roll system compared to other manufacturing methods. **Abundance of materials:** A vast supply of building block materials for organic solar cells is available, which should alleviate supply constraints, potentially reducing costs for solar applications.

Cons of organic solar cells:



Power conversion efficiency: The efficiency of OPVs is considerably lower than that of traditional silicon cells. Silicon cells typically achieve 20% – 25% efficiency, whereas organic solar cells currently reach only 8% - 12%. Lifespan: Organic solar cells have a shorter lifespan compared to traditional solar cells. Organic materials degrade faster when exposed to environmental elements."

Please note that the details provided in the revision are based on known information about organic solar cells and their current state of development.

1.3.10. Perovskite solar cells

Perovskite solar cells are composed of perovskite compounds. A perovskite refers to any compound whose crystal structure resembles that of calcium titanium oxide. Among the most common perovskites used in solar cells is methylammonium lead trihalide.

In the last decade, perovskite cells have witnessed a significant breakthrough. Their efficiency has remarkably increased from 3.8% in 2009 to 25.2% in 2020—an incredible leap. This substantial advancement has garnered increased attention from scientists and researchers.

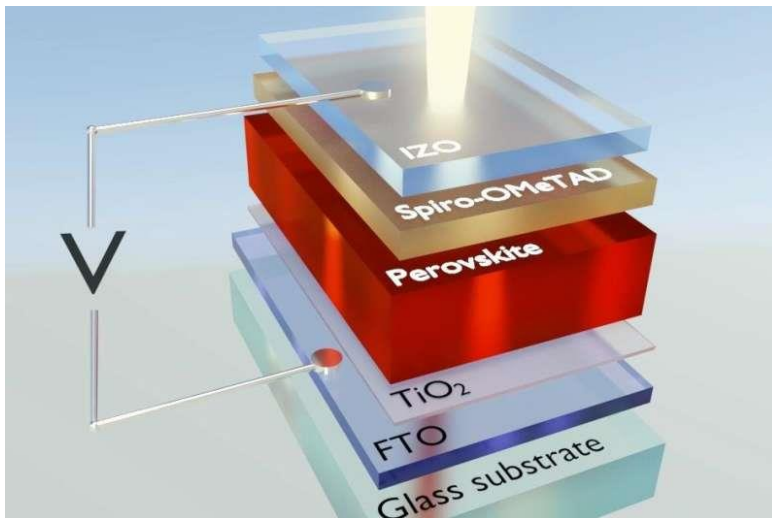

Figure: A Perovskite solar cells, source: <https://phys.org/news/2018-04-perovskite-solar-cells-efficient.html>

Furthermore, a specially optimized layer of perovskite can be incorporated in a 'tandem cell' arrangement alongside a traditional silicon cell. This tandem configuration enables the capture of photons that silicon cells are unable to convert, consequently enhancing power conversion efficiency.



The potential synergy between perovskite solar technology and high-performance silicon-based technology might hold the key to unlocking solar cells capable of converting 50% of sunlight into electricity. This is significant given that Maxeon currently leads the market with solar panels achieving an efficiency rating of 22.8%, converting electricity into usable power.

The crucial point to note is that while perovskite cell efficiency might not surpass the top-performing silicon solar cells, their cost-effectiveness will likely generate a substantially higher amount of electricity per dollar spent compared to silicon-based photovoltaic products.

The potential of perovskite solar cells is immensely promising and shouldn't be underestimated!

1.4. A brief overview of the types of photovoltaic systems and their application. 1.4.1. PV Industry Sectors

PV Industry Sectors

The PV industry comprises various tiers of businesses and organizations. At the first level are manufacturers, typically not in direct contact with clients, responsible for crafting essential components of the PV system: Modules, Inverters, Batteries, and the Balance of Systems. The second level involves integrators who act as intermediaries between clients and manufacturers. Integrators offer an array of services, including engineering design, preparation of permitting requirements, installation, monitoring, and operation and maintenance (O&M). They collaborate closely with architects, builders, contractors, and utilities to ensure compliance with standards, codes, and regulations. The third level encompasses installers, who can be independent entities like specialized electrical contractors focusing on PV installations or directly employed by integrators. Installers are highly visible in the PV industry, ensuring the safe and high-quality execution of installations.



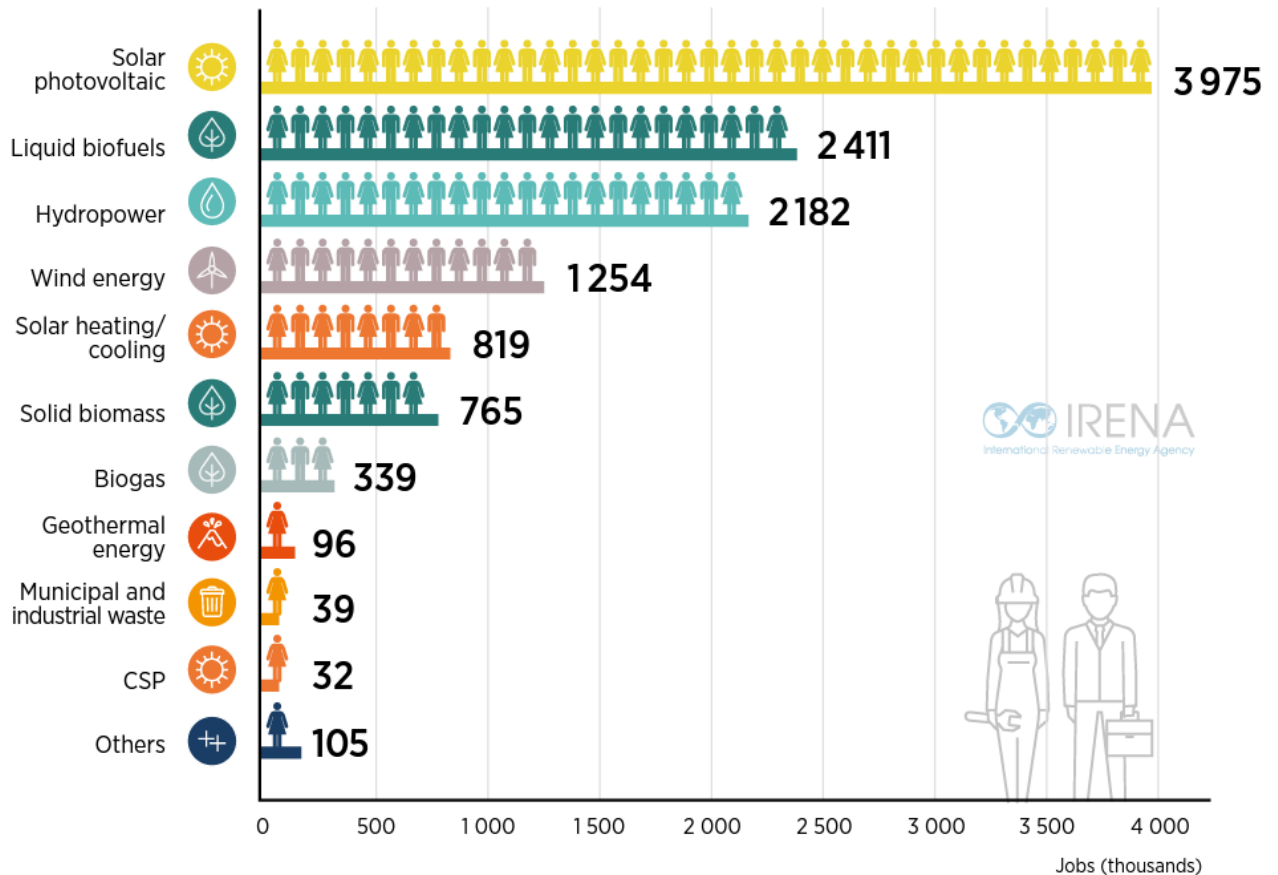

Note: CSP = Concentrated solar power. "Others" include tide, wave and ocean energy, and jobs not broken down by individual renewable energy technologies.

Source: IRENA Jobs database.

As per the International Renewable Energy Agency (IRENA) Annual Review 2021 [see Figure], the end of 2021 witnessed approximately 12 million workers in the renewable energy sector worldwide. Notably, the PV industry held the highest number of employees, boasting nearly 4 million workers globally engaged in PV solar-related occupations. This emphasizes the continued prominence of solar PV as the predominant renewable energy technology, highlighting the growing demand for qualified professionals in this field.

1.4.2. Types of PV Systems

Photovoltaic power systems are generally classified according to their functional and operational requirements, their component configurations, and how the equipment is connected to other power sources and electrical loads. The two principal classifications are grid-connected or utility-interactive systems and stand-alone systems. Photovoltaic systems can be designed to provide DC and/or AC power service, can operate interconnected with or independent of the utility grid, and can be connected with



other energy sources and energy storage systems.

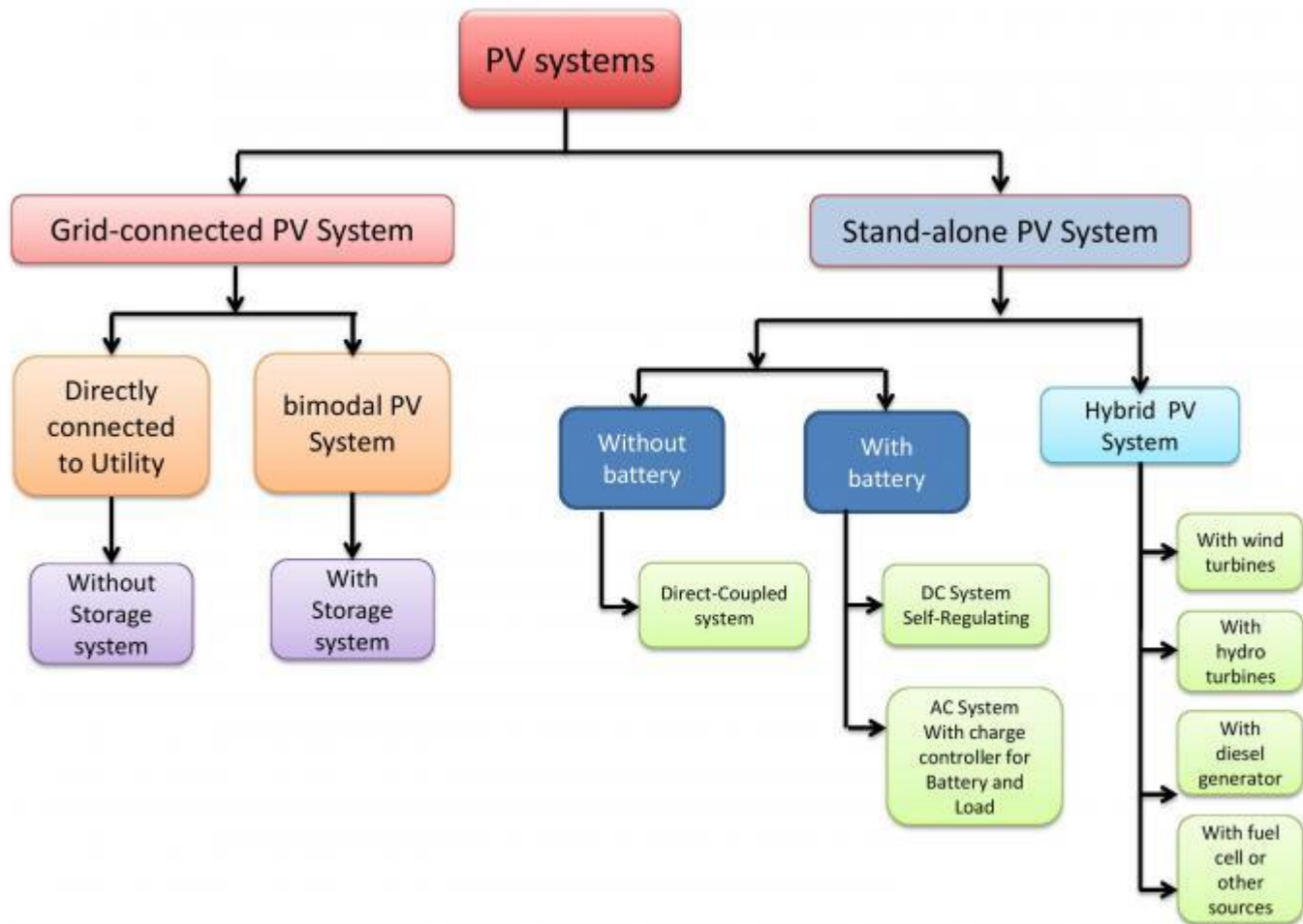

Figure 2: Classification of photovoltaic systems

While currently over 90 % of the world's PV systems are grid-connected, in the medium term it is expected that more and more stand-alone systems will be used, especially in developing countries. 30% of the world's population still lives without electricity. In these areas, photovoltaics can play a decisive role in gradual electrification.

Stand-Alone or Off-Grid PV Systems for a individual household power supplies, solar home systems, can be used to power lights, radios, televisions, a refrigerator or a pump, for example.

1.4.3. Grid-Connected Photovoltaic Systems

Grid-Connected Solar Photovoltaic Systems

A grid-connected solar photovoltaic (PV) system, otherwise called a utility-interactive PV system, converts solar energy into AC power. The solar irradiation falling on the solar panels generates photovoltaic energy, which is DC in nature. Using a DC-DC converter, the total photovoltaic DC voltage from the solar panels is raised to a higher DC level.

A DC-DC converter is not an essential part of a grid-connected solar PV system, but it can control the variations in the photovoltaic system and regulate DC voltage. The inverter in a PV system converts the DC voltage (either the DC voltage from the solar panels or the DC-DC converter output voltage) into AC voltage. As this AC voltage is integrated into the grid, the inverter converts the photovoltaic energy into AC power with a frequency that matches the utility grid. The voltage and power quality requirements of the grid are satisfied by the inverter AC output.

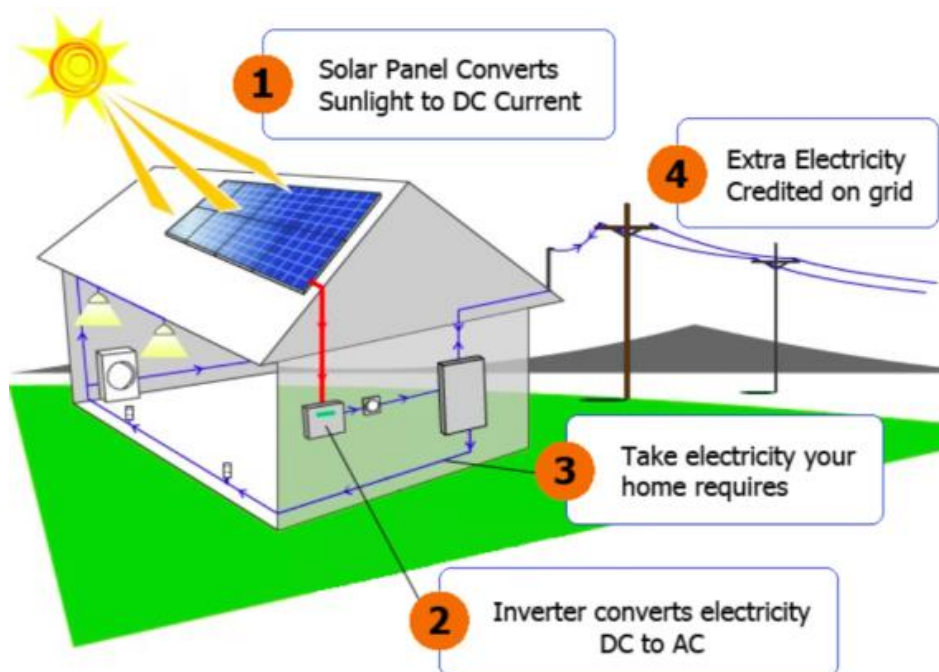

Figure: a **grid-connected solar photovoltaic (PV)** system, source quantumenergy.ca

Usually, a metering system is installed along with the solar PV system. In residences, when the PV system power is capable of supplying the complete load, utility grid power is not consumed. When PV power is scarce, the remaining power is consumed from the grid. If

the PV power generated is in excess, it is supplied to the grid. The solar PV system supplies power only when the grid is energized.

1.4.4. Stand-Alone or Off-Grid PV Systems

A stand-alone or off-grid PV system can be a DC power system or an AC power system. In both systems, the PV system is independent of the utility grid. If DC loads are connected to the solar PV system, then the solar panels can supply the DC voltage or a DC-DC converter can be used to convert the photovoltaic energy to higher DC levels. The DC-DC converter boosts the PV voltage to a value that is suitable for the DC loads. Incorporating the DC-DC converter can reduce the number of solar panels in the PV system.

When the loads connected are AC-powered devices, the off-grid PV system utilizes inverters for the conversion of PV voltage to AC voltage. In between DC-DC converters can also be incorporated to reduce the number of solar panels. A DC-DC converter can also be helpful in stand-alone PV systems when storing the PV voltage in batteries.

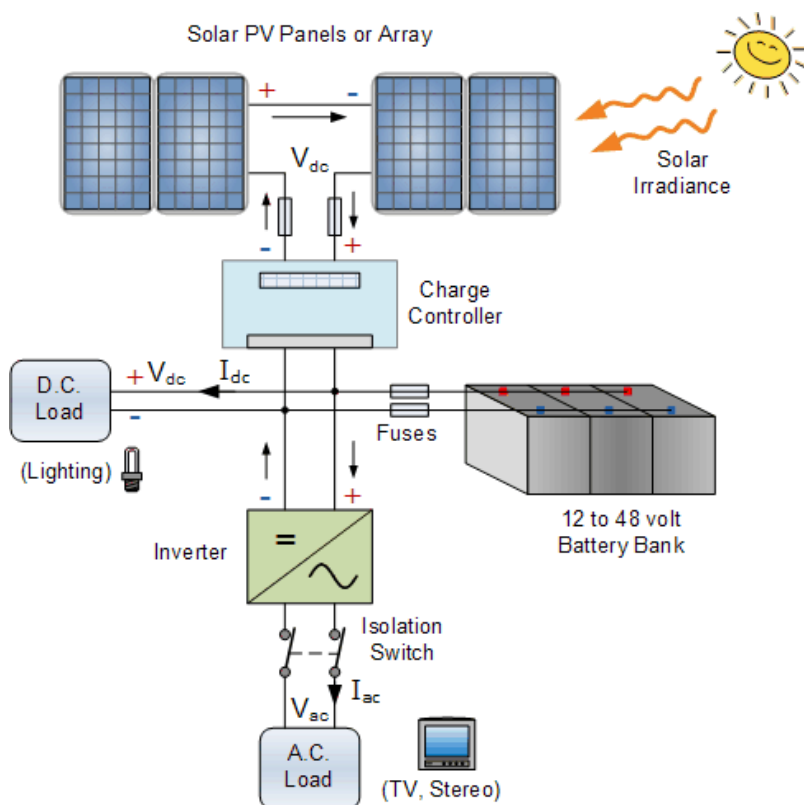

Figure: a stand-alone or off-grid PV system source: <https://www.alternative-energy-tutorials.com/>

The simplest type of stand-alone PV system is a direct-coupled system, where the DC output of a PV module or array is directly connected to a DC load (Figure 1). Since there is no

electrical energy storage (batteries) in direct-coupled systems, the load only operates during sunlight hours, making these designs suitable for common applications such as ventilation fans, water pumps, and small circulation pumps for solar thermal water heating systems.

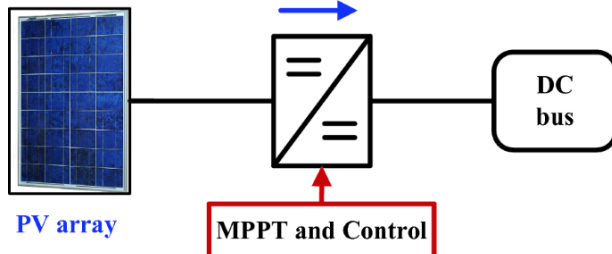

Figure: A direct-coupled system source: doi.org/10.1007/978-3-030-05578-3_17

Matching the impedance of the electrical load to the maximum power output of the [PV](#) array is a critical part of designing well-performing direct-coupled system. For certain loads such as positive-displacement water pumps, a type of electronic DC-DC converter, called a maximum power point tracker (MPPT), is used between the array and load to help better utilize the available array maximum power output.

1.4.5. Stand-Alone or Off-Grid PV Systems

Stand alone PV systems are ideal for remote rural areas and applications where other power sources are either impractical or are unavailable to provide power for lighting, appliances and other uses. In these cases, it is more cost effective to install a single stand alone PV system than pay the costs of having the local electricity company extend their power lines and cables directly to the home as part of a grid connected PV system.

A stand alone PV system is an automatic solar system that produces electrical power to charge banks of batteries during the day for use at night when the sun's energy is unavailable. A stand alone small scale PV system employs rechargeable batteries to store the electrical energy supplied by a PV panels or array.

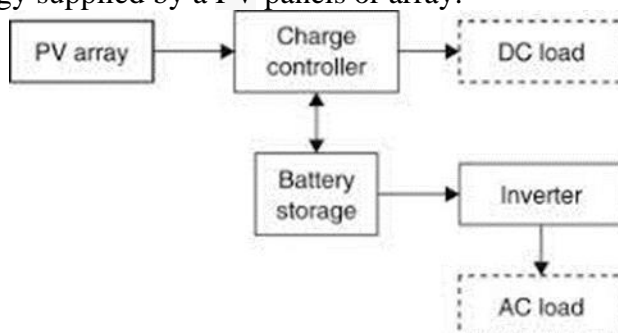

Figure: A block diagram for the stand-alone PV system, source: <https://www.alternative-energy-tutorials.com/>

The typically components for a stand-alone or off-grid PV system are:

Batteries are an important element in any stand alone PV system but can be optional depending upon the design. Batteries are used to store the solar-produced electricity for night time or emergency use during the day. Depending upon the solar array configuration, battery banks can be of 12V, 24V or 48V and many hundreds of amperes in total;

The inverter can be another optional unit in a stand alone system. Inverters are used to convert the 12V, 24V or 48 Volts direct current (DC) power from the solar array and batteries into an alternating current (AC) electricity and power of either 120 VAC or 240 VAC for use in the home to power AC mains appliances such as TV's, washing machines, freezers, etc.

A charge controller regulates and controls the output from the solar array to prevent the batteries from being over charged (or over discharged) by dissipating the excess power into a load resistance. Charge controllers within a stand alone PV system are optional but it is a good idea to have one for safety reasons.

1.4.6. Hybrid Solar PV Systems

A solar PV system can be integrated with other power sources, such as diesel generators or renewable sources like wind, to form a hybrid PV system. Different converters are utilized in these systems, depending on the types of sources combined with the solar PV panels, to convert energy into either DC or AC voltage.

In all PV systems, including hybrids, a maximum power point tracker (MPPT) is often utilized to ensure the maximum power is extracted from the PV arrays. While not mandatory, an MPPT significantly enhances the overall efficiency of solar PV systems.

Many renewable energy experts support the idea that a small "hybrid" electric system, combining home wind electric and home solar photovoltaic technologies, offers several advantages over individual systems.

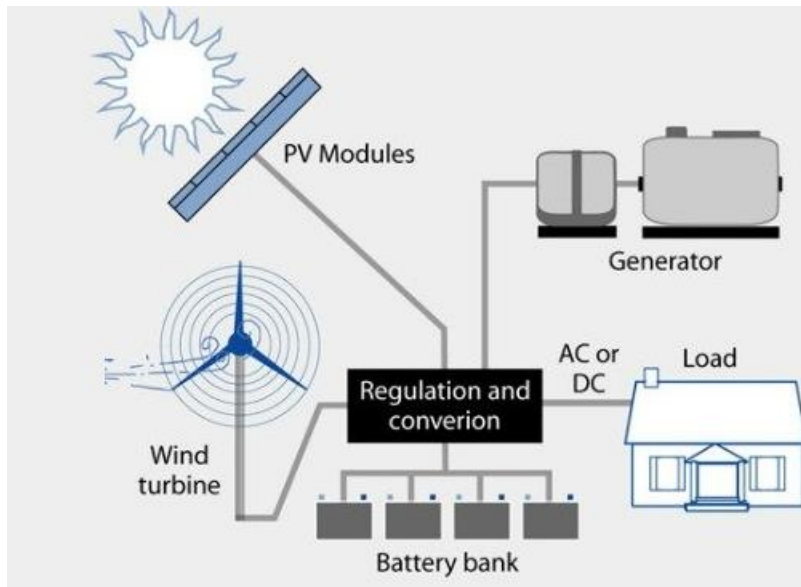

Figure: A hybrid solar **PV** systems, source <https://www.energy.gov/energysaver>

Hybrid systems operate independently "off the grid," meaning they are not connected to an electricity distribution system. During periods when neither the wind nor the solar system is generating power, most hybrid systems rely on batteries and/or an engine-generator powered by conventional fuels such as diesel. In the event of battery depletion, the engine generator can provide power while simultaneously recharging the batteries.

Although the inclusion of a motor-generator adds complexity to the system, modern electronic controllers can effectively manage these systems automatically. Additionally, the engine generator's integration can reduce the size requirements of other system components. It's essential to note that storage capacity must be sufficient to meet electricity needs during non-charging periods. Typically, battery banks are sized to sustain an electrical load for one to three days.

1.5. Evaluation and analysis of the terrain/building based on which the PV system must be introduced. 1.5.1. Measurement of Solar Radiation

Measurement of Solar Radiation

Before initiating the design and construction of photovoltaic systems, it's crucial to determine the available solar radiation at a specific location and time (such as a plot, building, or roof). This step is fundamental and serves as a mandatory starting point for our project. Hence, in this segment of the presentation, we'll delve deeper into the equipment and technology employed for measuring solar radiation.

These measurements and analyses remain essential throughout the extended operational phase of the photovoltaic installation. Understanding them proves beneficial in the long run.



Figure: A meteorological PV Station source <https://www.sevensensor.com/>

The Necessity of Meteorological Sensors for PV Plants

Solar radiation is commonly quantified through measured solar irradiance (power per area at a given time) or radiance, as well as solar insolation (energy per area delivered over a period). Solar radiation is depicted as instantaneous power density in units of kW/m^2 . It fluctuates throughout the day, ranging from 0 kW/m^2 at night to a peak of about 1 kW/m^2 . Its intensity is heavily influenced by location and local weather, exhibiting day-to-day variations. Solar radiation measurements typically involve periodic assessments of global and/or direct radiation, conducted using a pyranometer (for global radiation measurement) and/or a pyrheliometer (for direct radiation measurement). Such data have been consistently collected for over forty years at well-established sites, often within national meteorological institutes or university centers.

The information gathered by these sensors offers valuable insights into plant operation and potential avenues for improving performance. Even a minor reduction in plant efficiency can significantly impact energy output and subsequently affect the return on investment. Therefore, investing in low-cost sensors to monitor facility performance becomes crucial when considering the substantial investment involved in setting up a facility, as it unveils critical information and identifies issues within the plant.

1.5.2. Weather Stations for PV Plants

Weather stations play a crucial role in assessing the efficiency of solar power plants, utilizing an array of sensors for measurement. These stations calculate the energy output expected



from the plant and compare it with the actual energy produced. Subsequently, necessary maintenance or corrective measures are implemented based on the collected data.

Components of the Monitoring System

The typical system comprises essential sensors such as the solar radiation sensor, wind speed sensor, ambient temperature sensor, and module temperature sensor. Additional sensors, including those for wind direction, relative humidity, precipitation, and air pressure, can be integrated into the system to enhance data collection capabilities.

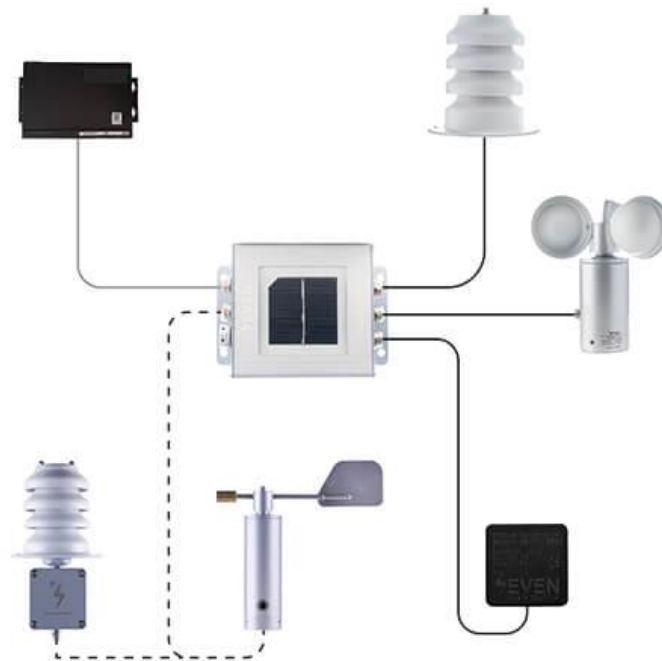

Figure: A schematic of a weather station for PV plant. source: <https://www.sevensensor.com/weather-stations>

Data Transmission and Monitoring

The meteorological data collected by these sensors are converted into an output signal based on the datalogger's request and then transmitted to the monitoring system. Data transmission can occur through various means, including Analog, Modbus RTU, Digital signals, or specialized communication protocols.

Monitoring and Control

Clients regularly monitor their power plants' energy performance remotely. Monitoring systems, which can either be proprietary systems from inverter manufacturers or specialized SCADA systems, consolidate the data received from inverters, sensors, and other

devices within the power plants. This data is initially gathered in dataloggers before being transferred to the monitoring systems for analysis.

Standard Sensors Used in Weather Stations

Irradiance Sensor (PV Pyranometer): This sensor measures radiation and often serves as a Reference Cell due to its high measuring accuracy. It's crucial in solar applications and usually equipped with additional ports for connecting other **sensors**.

Ambient Temperature Sensor: Monitors how production is affected by temperature variations and provides valuable data for analyzing the **PV** plant's performance.

Module Temperature Sensor: Positioned beneath the **PV** panel, it measures module temperature, a critical factor used to calculate the Performance Ratio.

Wind Speed Sensor: Measures wind speed and transmits data to the monitoring system.

Wind Direction Sensor: Determines wind orientation, offering valuable insight into wind patterns.

1.5.3. A pyranometer and how it measures the irradiance?

A pyranometer and how it measures the irradiance?

A pyranometer is a solar irradiance measuring device commonly used in various applications such as climatological research, monitoring weather stations in meteorological networks, greenhouses, building automation, reflectance studies, and weathering assessments.

PV systems, like solar collectors or PV plants, have a surface that gathers solar radiation. Determining the optimal orientation of this surface involves considering the solar energy collected from different directions. However, this task is complex because the sun's movement across the sky rarely allows direct sunlight to consistently reach a fixed surface. Moreover, various components of radiation (direct, scattered, and reflected from the ground) arrive at the surface from diverse angles. Additionally, changing weather conditions impact the availability of these radiation components over time. To accurately calculate this, meteorological sensors are employed to convert available data on solar radiation in the horizontal plane into radiation on a tilted flat surface.

The pyranometer measures total solar radiation received from the sky (both scattered and direct), typically in the horizontal plane. Therefore, the device must provide an unbiased response to radiation coming from all directions. It usually consists of a thermally sensitive sensor oriented horizontally and a glass dome that restricts the wavelength range, resembling the setup of a pyr heliometer.



Figure: Solar radiation is generally measured by two main devices: (a) Pyranometers and (b) Pyrhemimeters . source <https://www.sevensensor.com/>

Conversely, a pyrhemimeter specifically measures perpendicular solar radiation directly from the sun and a small portion of radiation coming from the sky around the sun. Sunlight typically enters the device through a glass window onto a thermocouple, a device converting heat into electricity. The generated electrical signal is recorded and converted into units of W/m^2 , representing solar radiation intensity.

The formula for solar radiation can be expressed as follows:

$$\text{Solar Radiation (W/m}^2\text{)} = \text{Solar Constant (W/m}^2\text{)} \times \text{Cosine of the Solar Zenith Angle}$$

Where the Solar Constant refers to the amount of solar radiation received per unit area outside Earth's atmosphere when the sun is at its average distance from the Earth, and the Solar Zenith Angle is the angle between the sun and the vertical at a specific location on the Earth's surface.

1.5.4. Why is a Site Survey Important Before Solar Installation?

Why is Site Survey Important before Solar Installation?

Performing a thorough site survey before solar installation is critical for several reasons:



Site Suitability Assessment: The survey helps determine if the site, whether a residence or commercial building, is suitable for installing solar panels. Factors like shading, orientation, roof condition, and available space are assessed to ensure the feasibility of a solar system.

Optimal System Placement: It identifies the best location on the property to install the solar panels, ensuring maximum exposure to sunlight throughout the day. This maximizes energy production and system efficiency.

Accurate Proposal and Design: Gathering information during the site survey enables accurate proposal creation and system design. It helps in estimating costs, determining system size, and selecting the most appropriate equipment for the specific site conditions.

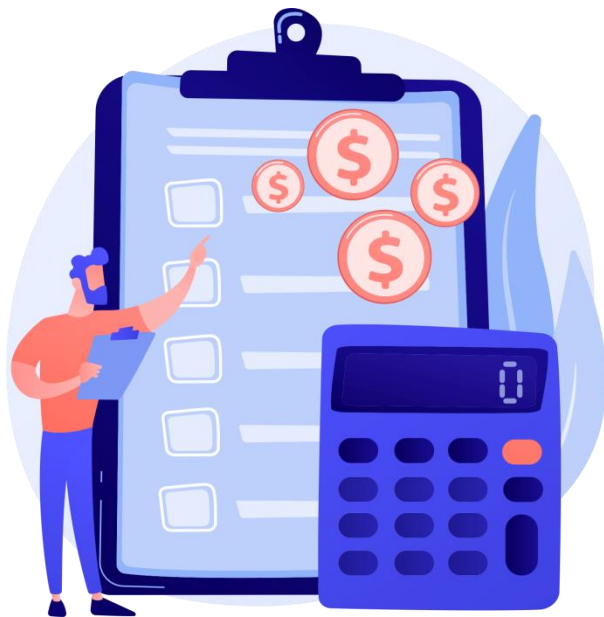

Figure: Evaluation and analysis of the PV system source :<https://emessolar.com/>

Prequalifying Leads: Pre-screening leads before conducting on-site surveys can save time and resources. Providing initial price estimates and ensuring prospects understand basic solar power concepts helps focus efforts on potential customers serious about adopting solar energy.

Remote vs. On-site Surveys: Some companies rely on remote site surveys using aerial images, online data, and owner-provided information. While this approach saves time in the sales process, others prefer on-site surveys for more accurate assessments despite potential **installation** challenges.

Understanding the intricacies of a solar site survey is vital, regardless of whether it's conducted remotely or on-site. This evaluation process plays a pivotal role in determining the success and effectiveness of the solar installation.

1.5.5. What is a solar site survey?

A solar site survey involves an in-depth inspection of a property to evaluate its suitability for the installation of a photovoltaic (PV) system. Here are the key components and objectives of a solar site survey:

Property Inspection: The survey entails examining the property, primarily focusing on the roof and electrical panel. This inspection helps assess the feasibility of installing solar panels and ensures the electrical **infrastructure** can accommodate the system.

Assessment of Obstructions: Identifying potential obstructions, such as trees or nearby buildings, that might cast shadows on the roof and affect solar panel efficiency is crucial. This evaluation helps determine the best location for panel placement to maximize sunlight exposure.

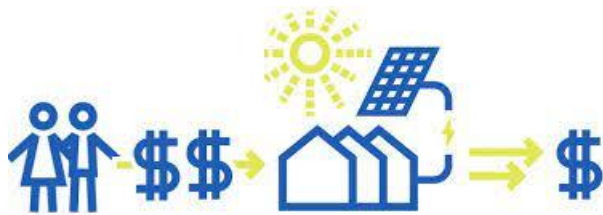

Figure: The site survey is your opportunity to gather all the information

Reviewing Historical Electricity Usage: Analyzing the client's historical electricity consumption aids in sizing the **PV** system appropriately to meet their energy needs efficiently.

Utilizing Solar Design Software: Some software tools provide features like shade analysis or roof space calculations based on aerial imagery. However, a physical site visit allows for verification of the data obtained through these tools, accounting for any recent changes or inaccuracies.

Identifying Installation Requirements: Gathering essential information necessary for the **installation** team, such as unique conduit routing or specialized tools needed for **installation**, ensures smooth execution of the project.

Overall, a solar site survey serves as a crucial step in the pre-installation phase. It allows solar professionals to gather precise information, assess the property's suitability, address potential

challenges, and ensure the design and installation process aligns with the client's specific needs and property conditions.

1.5.6. What to Look for During a Solar Assessment

A comprehensive solar assessment involves evaluating various parameters to determine the suitability and design considerations for a solar PV installation. Here are key aspects to consider during a solar assessment:



A comprehensive solar assessment involves evaluating various parameters to determine the suitability and design considerations for a solar PV installation. Here are key aspects to consider during a solar assessment:

Climate Conditions: Assess solar irradiation levels, temperature variations, and wind speed at the site. These factors determine the PV system's potential and the specific components required. Consideration of efficiency in different irradiation levels and temperature ranges is vital.

Type of Property and Roof: Define the property type (residential, commercial, etc.) and analyze the roof structure (RCC, Metal, etc.) as it impacts the solar system's design. Consider roof type, slope, and load-bearing capacity for panel installation.

Solar PV Array Location: Determine the optimal direction (south, south-east, south-west) for installing the solar PV array based on sunlight exposure.

Shade Analysis: Identify potential obstructions like buildings, trees, or structures that cast shadows on the solar panels. Ensure minimal shading to maximize electricity generation.



Space Availability: Measure available space on the roof or ground to determine the area for the solar PV system. Consider the roof's structure, nearby obstructions, and accessibility for installation.

Existing Electrical Connection: Gather information on the property's electrical connection—single-phase or three-phase, voltage, frequency, and main connection to the electricity grid—to analyze the solar system's integration.

Mounting Components' Location: Define the mounting locations for various system components like the distribution box, inverter, and wiring routes. For off-grid installations, plan the placement of batteries.

A thorough solar assessment considers these parameters to optimize the design, location, and efficiency of the solar PV system while addressing potential challenges or limitations presented by the site's characteristics.

1.5.7. How to Perform a Solar Site Assessment

How To Perform A Solar Site Assessment

Performing a thorough solar site assessment involves several crucial steps to ensure accurate planning and installation. Here's a breakdown of the key tasks to complete during a site visit:

Inspect the Main Service Panel: Evaluate the main electrical service panel to determine its capacity and safety:

Assess available space for a solar circuit.

Verify if the amperage of the panel meets current and potential future electrical needs, considering plans for electric vehicles (EVs) or new appliances.

Ensure the panel's safety to prevent potential fire hazards.

Document Shading and Obstructions: Evaluate potential shading sources on the roof:

Examine the south, west, and east sides of the roof for existing or possible future obstructions.

Anticipate tree growth and their potential shading impact on the roof over the system's lifespan.

Discuss with the property owner the possibility of tree trimming to improve solar exposure.

Assess Roof Condition: Examine the roof's condition and age:

Identify signs of damage like missing or damaged shingles, cracks, flashing issues, or pooling.

Inquire about past roof leaks and inspect the attic for water damage signs.

Evaluate Roof Dimensions and Structure: Gather roof-specific data:

Measure roof dimensions, pitch, and assess rafter spacing.

Consider using solar design software or manual measurements to plan system **installation** and account for any structural challenges.

Gather Additional Information: Obtain supplementary details from the homeowner:

Determine the roof's age to evaluate its remaining lifespan.

Collect electricity bills to estimate historical energy consumption.

Inquire about specific preferences or requirements regarding inverter placement and conduit routing.

Taking detailed notes and photographs during the assessment is crucial for reference and decision-making during the system design and installation phases. Additionally, communicating effectively with the property owner helps gather vital information needed for an accurate solar installation plan.

1.6. Main steps and activities to be planned to realise a small PV system. 1.6.1. Planning a home PV residential system

Planning a home PV residential system

Planning a residential PV system involves careful consideration and steps to ensure optimal energy efficiency and the right system size for the home. Here's a breakdown of key steps to follow:



Figure: Home Energy Audit source: <https://connected.org.au/resource/home-energy-audit/>

Research Home Energy Efficiency:

Conduct an assessment of the home's current energy usage and potential future needs.

Perform a home energy audit to identify areas of energy wastage and potential improvements.

Explore low-cost measures for efficiency enhancement before choosing the final **PV** system option.

Explore Efficiency Resources:



Co-funded by
the European Union

Funded by the European Union. Views and opinions expressed are however those of the author(s) only and do not necessarily reflect those of the European Union or the European Education and Culture Executive Agency (EACEA). Neither the European Union nor EACEA can be held responsible for them.

Utilize resources such as home energy audits to understand energy wastage and implement improvement measures.

Consider upgrading to energy-efficient appliances and electronics.

Opt for energy-efficient lighting solutions like LED bulbs.

Address heating and cooling systems, aiming for efficient use to reduce overall electricity demand.

Consider Heating and Cooling Needs:

Assess the home's heating and cooling requirements, especially if electricity powers these systems.

Optimize heating and cooling efficiency to minimize the electricity demand that needs to be covered by the solar energy system.

Implement measures to efficiently manage home humidity, as this also impacts the electricity needs for heating and cooling.

These steps are crucial as they help in understanding the current energy usage patterns, identifying potential areas for efficiency improvements, and ensuring that the solar PV system selected is appropriately sized to meet the home's needs efficiently.

Understanding and optimizing energy usage before installing a PV system not only maximizes the benefits of solar energy but also helps in reducing overall electricity consumption, making the solar solution more effective and cost-efficient for the homeowner.

1.6.2. Assess Your Solar Potential

Assessing your solar potential before opting for home solar electricity is crucial. Here are key points to consider during this evaluation:

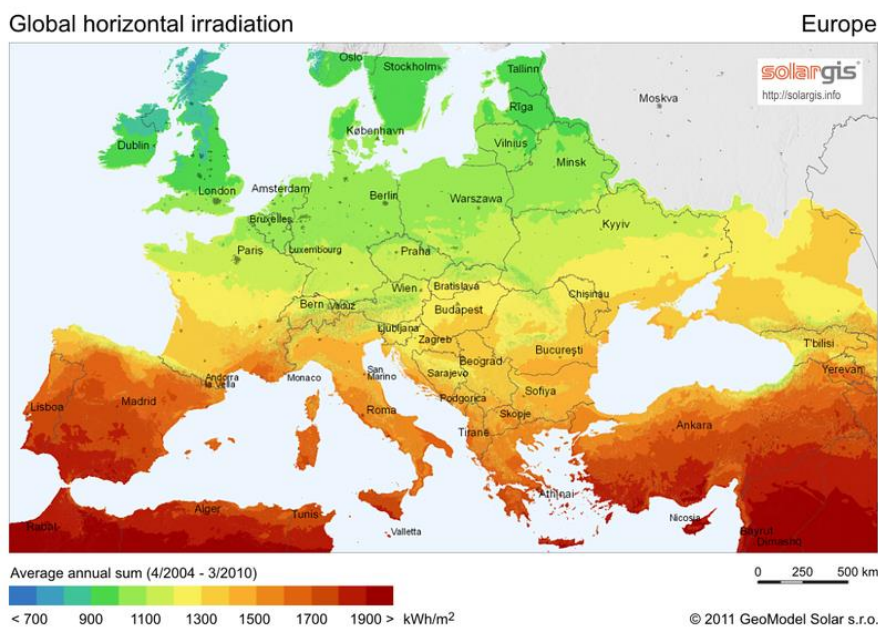

Co-funded by
the European Union

Funded by the European Union. Views and opinions expressed are however those of the author(s) only and do not necessarily reflect those of the European Union or the European Education and Culture Executive Agency (EACEA). Neither the European Union nor EACEA can be held responsible for them.

Figure: Global horizontal irradiation in Europe,

source: DOI: [10.1109/EEEIC/ICPSEurope49358.2020.9160790](https://doi.org/10.1109/EEEIC/ICPSEurope49358.2020.9160790)

Solar Resource Suitability in Europa:

Europa boasts ample solar resources suitable for home solar electric systems, utilizing both direct and scattered sunlight for electricity generation.

Factors Affecting Solar Power Generation:

The quantity of power generated by a solar energy system at a specific location depends on the amount of sunlight received and the system's size.

Use of Mapping Services and Tools:

Explore available mapping services and tools to estimate your home's solar energy potential. These tools offer insights into estimated system size, potential costs, savings, and information about local contractors.

Limitations of Mapping Tools:

While mapping tools are a helpful starting point, they may not encompass all variables specific to your situation.

Engage directly with a solar installer for a more precise assessment, tailored recommendations, accurate estimates, and specialized equipment insights.

Consider Other Critical Factors:

Evaluate potential shading from nearby trees, including future growth that could impact the solar system's efficiency.

Assess the condition and remaining lifespan of your roof; consider replacing it if required before installing solar panels.

Be aware of neighborhood or HOA restrictions related to solar installations; investigate "solar rights provisions" specific to your state laws and HOA covenants.

By considering these factors and collaborating with a solar installer, you can gain a comprehensive understanding of your home's solar potential. This approach ensures a well-informed decision regarding solar energy implementation while addressing specific considerations relevant to your location and property.

1.6.3. Estimate Your Solar Electricity Needs

Estimate Your Solar Electricity Needs

Estimating your solar electricity needs involves gathering information about your home's energy usage to assist your contractor in recommending the appropriate type and size of the system. Here's a step-by-step guide:





Figure: How much solar I do need? source: <https://www.solarreviews.com/>

1.Review Electricity Bills:

Gather your electric utility bills from the past year and identify the monthly kWh usage. Consider seasonal variations in your energy consumption, noting high and low consumption months, especially if certain appliances (like air conditioners) significantly affect usage.

2.Consider Planned Changes:

Anticipate any upcoming changes that might affect your energy needs, such as purchasing an electric vehicle or planning home additions.

If you're making energy-efficient upgrades, factor in potential reductions in your energy consumption.

3.Determining Solar Energy Needs:

- **For Grid-Connected Systems:**
 - Typically, solar energy needs may range from 50% to 100% of your annual kWh usage.
 - The percentage of your electricity bill you wish to offset may depend on available space and budget for the PV system.
 - Grid-tied systems often generate excess power during the day, which is sent back to the grid via net metering, crediting your account for surplus power.
- **For Off-Grid Systems:**
 - Calculate the energy load needed in AC kWh, considering detailed information about devices, power consumption (in Watts), duration, and frequency of use.
 - Multiply the device's power consumption by the hours of use to calculate its energy consumption (in kWh).

4. Determining Solar Power Needs:

- **For Grid-Connected Systems:**



- Use a solar power calculator, input your annual kWh usage from the utility bill, daily sunlight hours for your location (from a solar power map), and the desired percentage of your utility bill to be offset.
- Calculate the DC watt size needed for your solar PV system based on these factors.

5. Selecting a PV System:

- Once you determine your power needs, select a PV system that aligns with your lifestyle and budget. You're not obligated to offset 100% of your energy use.

This step-by-step process helps in accurately estimating your solar electricity needs, facilitating informed decisions when choosing the appropriate solar system for your home or business. Working with a qualified solar contractor can further assist in making precise calculations and selecting the optimal system size for your specific requirements and location.

1.6.4. Get quotes and site estimates from solar installers.

When seeking quotes and estimates from solar installers for your PV system, it's crucial to ensure you're working with qualified professionals. Here's a step-by-step guide to effectively evaluate and select a solar installer:

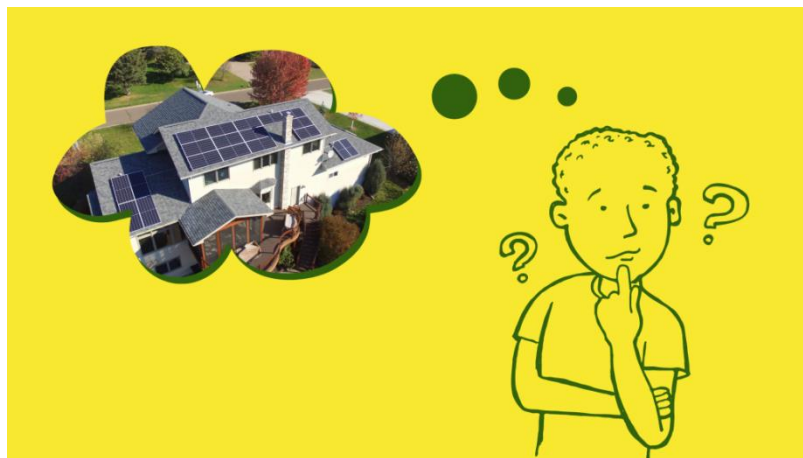

Figure: Get quotes and estimates for the company that will install the solar system

source: <https://www.nesfircroft.com/> =

1. Research Qualified Installers:

- Look for certified and insured professionals with the appropriate solar industry certifications accredited in your country. Seek recommendations from friends, family, and online resources.



- Verify the installer's certification and ask for proof of a valid license before finalizing any agreement.

2. Get Multiple Quotes:

- Obtain at least three quotes from different solar installers. Ensure these quotes are based on the same features and metrics for fair comparison.
- Online tools can aid in finding and comparing various solar installers, facilitating a streamlined selection process.

3. Questions to Ask Potential Installers:

- Inquire about their familiarity with local resolution and interconnection processes to expedite system installation and connection.
- Request referrals from other customers in your area to understand their experiences and the company's problem-solving capabilities.
- Clarify the warranty terms for the system and inquire about system operation, maintenance, and repair responsibilities. Quality equipment and maintenance plans are crucial indicators.
- Verify the company's licensing and certifications, ensuring compliance with state and local regulations. Check for any pending judgments or liens against the company.
- Evaluate the total cost breakdown for the PV system, including hardware, installation, grid connection, permits, and warranties. Comparing costs/watt and estimated costs/kWh can help gauge prices across installers.

By asking these questions and comparing quotes based on standardized metrics, you can effectively evaluate solar installers and select the one that best fits your needs. Prioritizing experienced, certified professionals and comprehensive warranties ensures a reliable and efficient installation process for your solar PV system.



2. Basic components in photovoltaic system architecture

Content

- 2.1. Components of photovoltaic systems - structure, types and characteristics.
 - 2.2. Junction box purpose and main elements.
 - 2.3. Connecting elements and technology in photovoltaic system installation.
 - 2.4. Inverter role, functional options and different types.
 - 2.5. Solar batteries
 - 2.6. The role of the DC and AC load switches.
 - 2.7. Monitoring and control of PV installations
- 2.1.Components of photovoltaic systems - structure, types, and characteristics. 2.1.1.
Introduction



2.1.1 Въведение

To avoid repetition and enhance clarity, you might consider rephrasing the second sentence like this:

The section on 'Photovoltaic System Components' encompasses the primary electrical elements integral to a photovoltaic system.

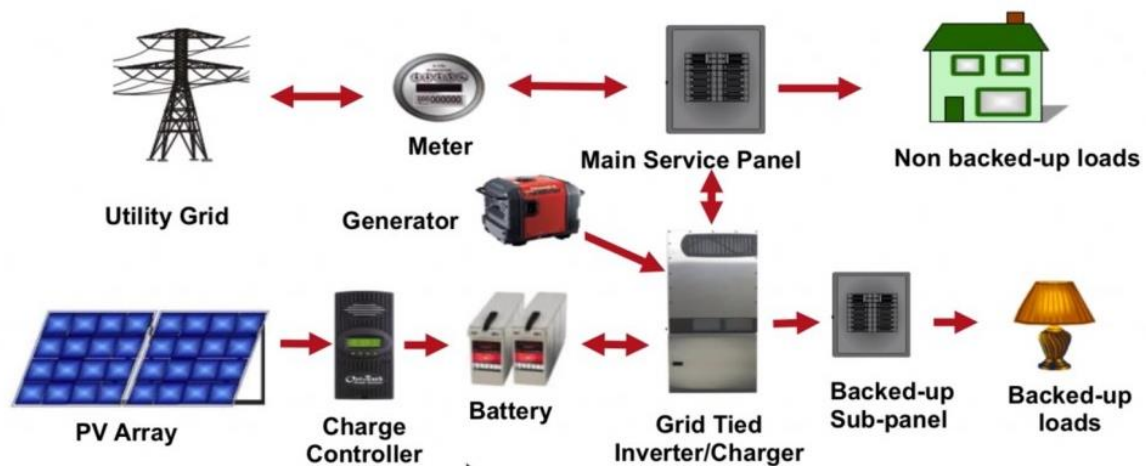

Figure: Principle of a grid/hybrid PV system, source: <https://www.solarpowerworldonline.com/>

A comprehensive photovoltaic system comprises various components, each chosen based on individual requirements, site specifics, climate, and anticipated outcomes. This section aims to elucidate the functions of these components and explore diverse system types.

The selection of components hinges upon functional and operational prerequisites, defining the system's composition. These may involve pivotal elements like a DC-AC power inverter, battery storage, a system controller, and a specified electrical load management system for appliances.

2.1.2. Structure of a photovoltaic modul. 2.1.2.1. Series connection in crystal cells in the module

In this segment of our presentation, we will delve deeper into the realm of photovoltaic modules, focusing on both their electrical characteristics and their

geometrical dimensions, along with their mechanical durability. Design attributes and module-specific features hold substantial importance. Quality certificates accompanying these modules provide a certain level of assurance regarding their operational parameters and properties, warranting thorough analysis and reporting.

2.1.2 Structure of a Photovoltaic Module 2.1.2.1 Series Connection of Crystalline Cells in the Module

The manufacturing process of a PV module with crystalline cells begins by connecting the solar cells in series due to their low voltage (cell stringing). This involves soldering the front contacts of one cell to the back contacts of the next cell (refer to the figures).

Most manufacturers opt for lead-free solder or connections. By linking the negative pole (front) to the positive pole (back) of the following cell, the cells align in a series. The distance between the cells typically spans several millimeters.

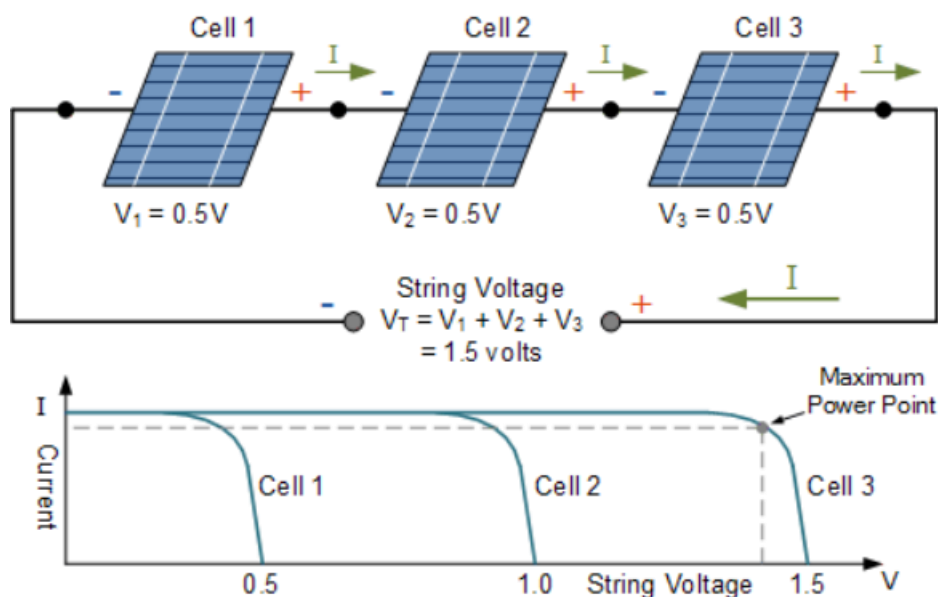

Figure: Cell **interconnection** in the standard module source: <https://www.alternative-energy-tutorials.com/photovoltaics>



Figure: External Series connection of crystalline solar cells source: <http://www.work-crew.de/photovoltaik/>

2.1.2.1 Series Connection of Crystalline Cells in the Module.

In standard modules, typically 36 to 72 cells are connected in a single string. The interconnection within the module occurs lengthwise, where usually 9 to 12 cells are grouped in 4 to 6 geometric rows of cells (often referred to as cell strings), forming a serial connection. Alternatively, there are configurations where 18 to 20 cells are interconnected in two to three strings. The start and end points of the string, or the parallel strings, along with the terminals for bypass diodes, are usually brought out at a single point through the rear foil for electrical connection.

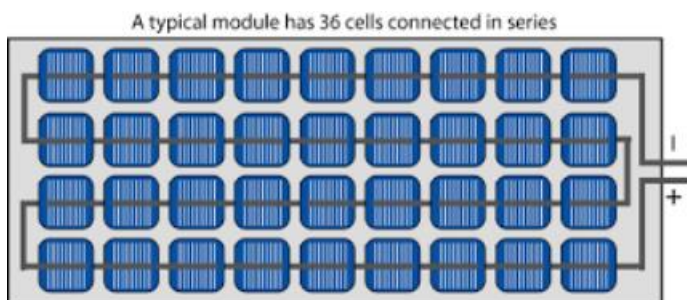

Figure: Serial cell connection in the standard module source: <https://www.pveducation.org/pvcdrom/modules-and-arrays>

2.1.2.2 Series Connection of Thin Film Cells in the Module

Unlike crystalline cells, where interconnection occurs cell by cell in a distinct manufacturing stage, thin-film cell electrical connections are integrated during the cell production process through separating steps in the individual layers. The materials are sliced into 0.5 to 2 cm wide cell strips, achieved either by laser cutting or mechanical scratching.

The diagram illustrates the construction technique of these cells, displaying the layers when deposited on the substrate. This method is commonly observed in CdTe modules and the majority of amorphous silicon modules.

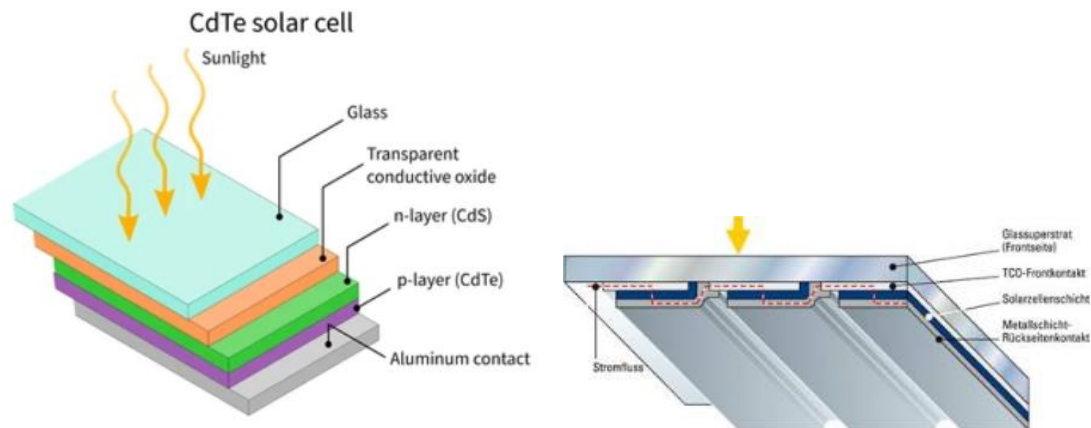

Figure: Integrated Series connection of thin-film cells out amorphous silicon or CdTe

The manufacturing process begins with the application of the TCO (transparent conductive oxide) layer, which is subsequently divided into parallel strips. The semiconductor layer of the solar cells is then deposited atop these strips. The deposition of the second layer occurs slightly offset and in parallel to the first line. Finally, the back contact is applied, constituting the last step in this process.

This sequential procedure results in an electrical connection from the back contact of the first cell to the front contact of the next cell. Consequently, the individual strip cells are connected in series, forming the desired configuration

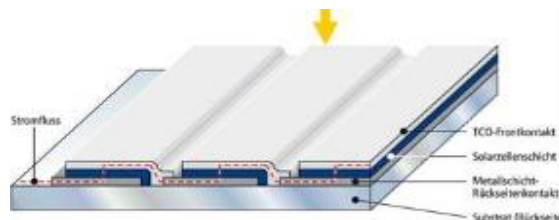

Figure: Integrated Series connection of thin-film cells from CIS or amorphous silicon

CIS cells are typically deposited in a reversed sequence on molybdenum-coated glass (substrate), necessitating an additional layer of glass as the front cover. The molybdenum serves as the rear contact in this configuration. Some manufacturers opt to deposit CIS or amorphous cells on metal foils or polymer foils, such as UniSolar, Flexcell, FujiElectric, PowerFilm, Odersun, GlobalSolar, NanoSolar, and Daystar. Flexible modules are engineered by embedding these foils coated with solar cells into transparent front foils

2.1.2.3 Solar glass

To safeguard photovoltaic cells from mechanical stress, the effects of time, and moisture, they are encapsulated within a transparent composite material. This composite layer not only shields the cells but also serves as electrical insulation. For structural support, this composite assembly is affixed to a base material. Typically, low-iron white glass is utilized as the front substrate, enabling up to 96% transmission of light due to its heightened transparency, achieved by minimizing iron oxide content. To withstand elevated thermal stress, this glass undergoes tempering, hence earning the term 'solar glass'.

Two primary production methods exist for solar glass: float and rolling processes.

Float glass is commonly employed in thin-film modules. Throughout production, the glass surface is often etched and coated with Transparent Conductive Oxides (TCO) or a molybdenum back contact.

Rolled glass, also known as cast glass, finds usage in crystalline modules. During manufacturing, molten glass is fed between rollers, allowing patterns to be imprinted on the glass.

Standard solar glass thickness ranges from 3 to 6 mm, dependent on module size. For larger modules or specific design needs, glass up to 10 mm thick may be used. While operating modules shielded by solar glass, losses primarily arise from reflection. Consequently, glass manufacturers are developing various anti-reflective coatings for photovoltaic modules, enhancing light transmission into the solar cells by up to 5%.

The most significant performance improvement is observed when sunlight strikes the module at an angle, with energy gains reliant on installation location and angle. Currently, only a few module manufacturers prioritize the use of anti-reflective glass due to marginal yield increases and limited long-term experience with coating durability and increased susceptibility to contamination.

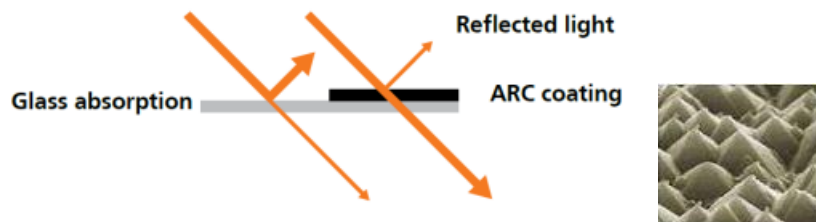

Figure 6: The effect of solar and anti-reflective glass,

source: <https://www.cleanfuture.co.in/2019/09/02/anti-reflective-coating-on-solar-panels-increases-efficiency/>



2.1.2.4 Encapsulation in ethylene vinyl acetate (EVA) - crystalline modules

Photovoltaic modules comprise various components designed to shield the solar cells from external factors, with one such crucial component being the EVA encapsulant.

EVA, short for ethylene vinyl acetate, is a material renowned for its excellent radiation transmission and resistance to sunlight degradation. This thermoplastic polymer serves as an encapsulation agent within solar modules. When subjected to heat during assembly, it forms a protective and insulating film around the solar cells. This film effectively seals the cells, preventing the ingress of air and moisture. Simultaneously, it allows the transmission of solar energy while maintaining resilience against degradation caused by prolonged exposure to sunlight

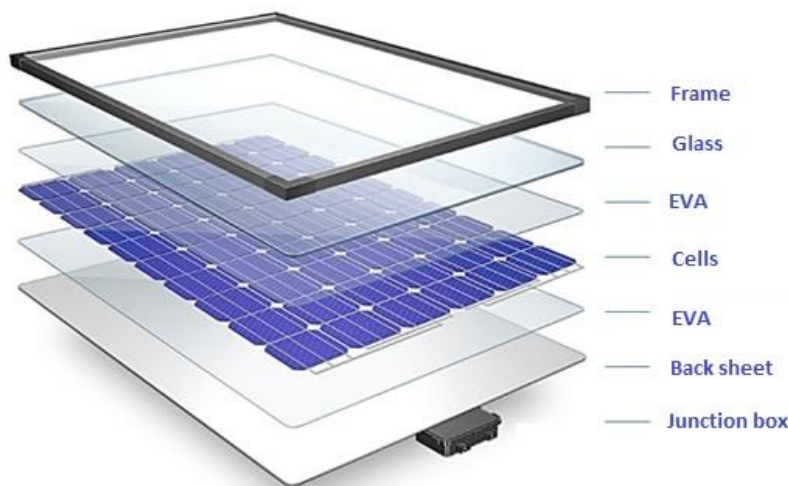

Figure: Encapsulation in ethylene vinyl acetate (EVA) source: cleanerenergyreviews.info

At present, more than 95% of PV modules utilize EVA encapsulation. In this process, crystalline solar cells are sandwiched between two layers of EVA film along with a front glass and a rear film within a vacuum chamber. Negative and positive pressures are applied while subjecting the assembly to temperatures of up to 150°C, facilitating the formation of a laminate (known as the vacuum lamination process). The EVA melts during this procedure, completely enveloping the solar cells.

For UV-resistant weather protection on the front side, tempered glass, often highly transparent white glass (solar glass), is commonly used. Conversely, the back side of standard modules is typically covered with an opaque laminated film, occasionally substituted with ordinary tempered glass. EVA encapsulation boasts high transmittance and resistance to both heat and saltwater, exhibiting remarkable durability and reliability. However, its stability makes repairs challenging, and the modules are typically only viable for thermal recycling

2.1.2.5. Encapsulation of thin film cells

Three alternative absorber materials are used for manufacturing solar cells with CIGS thin-film technology: amorphous silicon (a-Si) or a combination of amorphous and microcrystalline silicon (a-Si/ μ c-Si), the compound semiconductor cadmium telluride (CdTe) or a compound semiconductor made of copper, indium, gallium and selenium (Cu(In,Ga)Se₂, CIS or CIGS for short). Solar cells made from the three aforementioned materials are called thin-film solar cells because the absorbers are only a few micrometres thick.

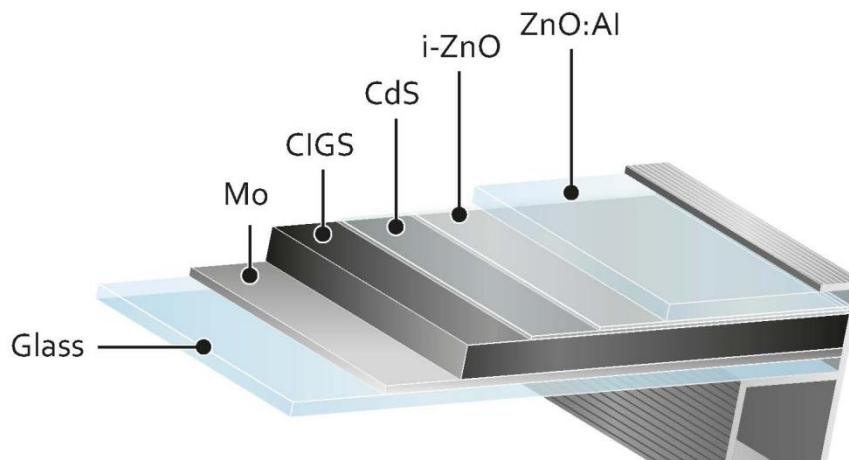

Figure: CIGS Thin Film Technology Architecture

These absorbers are not self-supporting like silicon wafers but are deposited on substrates, which are mostly glass panes. The manufacture of thin-film modules therefore differs fundamentally from the manufacture of silicon-based technology. The contact surfaces, absorber and additional intermediate layers are deposited on large glass panes in integrated processes. The layers are then laminated together under a second glass panel to form a finished solar module. Today, CIS or CIGS technology is the thin-film technology with the highest levels of cell efficiency. The record stands now at 23.35 % (Solar Frontier). With this value, CIGS has the best qualifications for further strong market growth. This is real thin-film technology (the total thickness of all the layers is just a few thousandths of a millimetre on substrates made of window glass or metal or plastic films), and is mostly based on processes which have already proved their worth in architectural glass coatings.

2.2. Junction box purpose and main elements.

2.2.1 The solar panel junction box is the output interface of the solar module.

In order to bring the electrical connecting cables of the module outside, special holes are used on the back glass with holes or those on the back foil. In these cases, a junction box is glued over the passage opening.



Figure: Junction box glued to the back of the solar panel. source: <https://sinovoltaics.com/learning-center/materials/pv-junction-box-purpose-and-connection/>

Each solar junction box has two wires. One wire is the DC positive (+), and the other is the DC negative (-).

In the junction box are the contacts of the cables for connecting the modules and the bypass diodes. Conventional silicon diodes are used as bypass diodes, and more recently Schottky diodes.

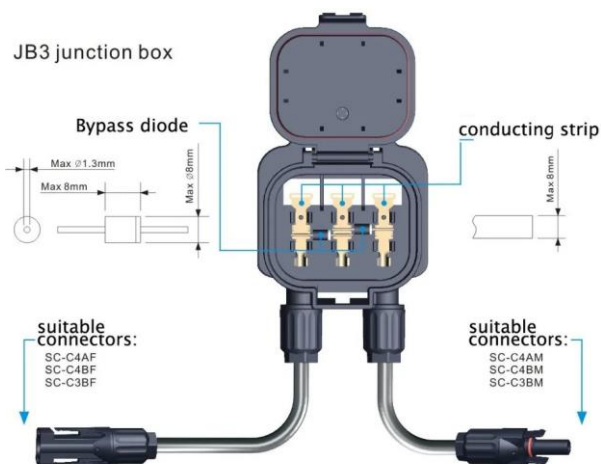

Figure: Junction box of solar panel. source: www.electrical24x7.com

When the modules are shaded, diode forward voltages of 0.4 to 1 V lead to strong heating, so sufficient heat dissipation must be provided. The junction box of the module must have at

least IP 55 (category 1 according to EN 60529) and protection class II and comply with the European standard EN 50548 "Junction boxes for photovoltaic modules".

A quality solar panel junction box minimizes corrosion at the terminals; as it will exclude that moisture enters the PV panel. To prevent water ingress, drip holes must be provided during installation.

The majority of solar junction boxes have at least an IP65 rating.

A quality solar panel junction box has an IP67 or IP68 rating.

To facilitate installation, almost all modules are supplied with connection cables and specialized protected touch-resistant connectors.

To facilitate the installation of the modules, "Plug & Play" technology has become standard. Almost all modules are supplied from the factory with 1 to 1.5 m connection cables and touch-resistant connectors. They must meet the requirements of standard EN 50521. Good connectors have a contact resistance of less than 0.5 milliohm, so a current of 5 A results in a very low voltage drop - less than 0.025 V. Unfortunately, it is not possible to agree on uniform connector format, which is why there are a large number of different connectors on the market.

2.2.2 Classification of junction boxes

Junction boxes are primarily categorized into two types: ordinary and potted.

An ordinary junction box is sealed using a silica gel sealing ring, while a rubber-filled junction box is filled with a two-component silica gel. The ordinary junction box is simpler to use and operate initially, but over time, the sealing ring can be prone to aging. On the other hand, the operation of the potted junction box is more complex, involving the filling of two-component silica gel and curing. However, this complexity results in an effective and durable sealing, exhibiting better resistance to aging. Moreover, potted junction boxes generally come at a slightly lower price point.

Junction boxes can also be classified based on power and connector types, as well as the working current of the diode



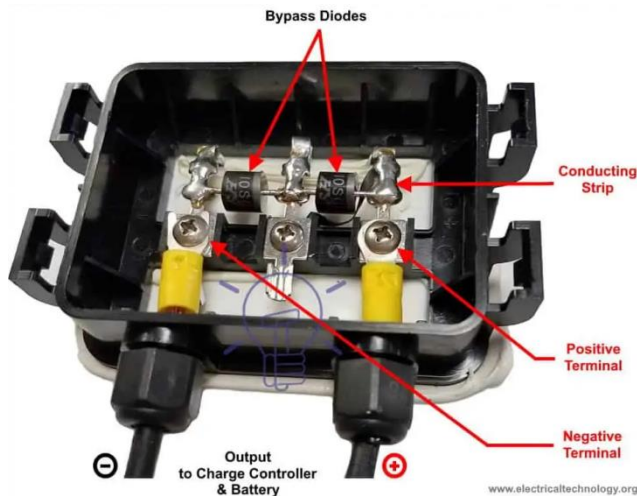

Figure: Composition of solar panel,

source: <https://www.pinterest.com/pin/475270566927467043/>

Composition

The junction box comprises various components such as the box body, box cover, connectors, terminals, diodes, and additional elements. While some manufacturers incorporate heat sinks for optimizing temperature distribution within the box, others focus on different design aspects, although the fundamental structure remains consistent.

Box Body

The box body serves as the primary component of the junction box, housing built-in terminals and diodes, along with external connectors and the box cover. It acts as the framework of the junction box and is responsible for meeting most weather resistance requirements. Typically, the box body is constructed using PPO (polyphenylene oxide), one of the world's five general engineering plastics. PPO boasts several advantages, including high rigidity, elevated heat resistance, fire resistance, remarkable strength, and excellent electrical performance. Furthermore, polyether exhibits wear resistance, non-toxicity, and resistance to pollution.

Electrical Performance

The electrical performance of the junction box encompasses parameters such as working voltage, working current, resistance, and other crucial factors. Assessing the electrical performance is essential to determine the junction box's quality and compliance with.



2.3. Connecting elements and technology in photovoltaic system installation.

2.3.1 Photovoltaic cable

Cables, lines and connection technology

Solar cables and wires are integral components of any electrical system, especially in photovoltaic setups. They play a crucial role in linking circuit components, facilitating the transfer of electrical energy generated by PV modules to the electrical modules within the PV system, and eventually to the end consumers. Therefore, understanding the fundamentals of solar wires and cables is paramount.



Figure: PV cables and adapters source: <https://www.ebay.com>

Definition of Solar Cable and Photovoltaic Cable

Solar cable refers to the interconnection cable specifically utilized in photovoltaic power generation. These cables serve as connectors between solar panels and other electrical components within a photovoltaic system.

Solar cables are engineered to withstand UV exposure and various weather conditions. They are designed to function effectively across a wide temperature range, typically ranging from -40°C to +90°C. Key features required in solar cables include resistance to ultraviolet light, weather durability, capacity to withstand extreme temperature fluctuations, and insulation suitable for the specific voltage class of the equipment.

The terms 'solar cable, PV cable, PV wire, or photovoltaic cable are often used interchangeably.

Varieties of solar wires are utilized for connecting different components within a photovoltaic system. Typically, these wires facilitate connections between four primary components: solar panels, inverters, charge controllers, and batteries. Selecting the

appropriate wire type in a PV system is crucial for its optimal operation and efficiency. Using an incorrect solar wire may lead to voltage discrepancies, resulting in ineffective power supply to electrical modules or insufficient charging of the battery.

2.3.1.1 Types of photovoltaic cable

Solar cables and photovoltaic cables are categorized into various types based on different requirements.

While 'solar wire' and 'solar cable' are terms often used interchangeably, they hold distinct meanings. A solar wire refers to a single conductor, whereas a solar cable comprises multiple conductors or wires held together by a protective jacket.

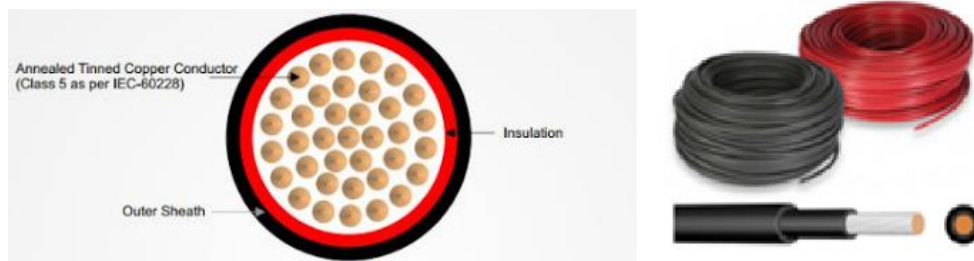

Figure: Single-core and multi-core cable

Solar wires are employed to interconnect various components within a photovoltaic system, typically linking four primary elements: solar panels, inverters, charge controllers, and batteries. The selection of the appropriate wire type is crucial for the efficient operation of a PV system. The wrong type of solar wire might lead to inadequate voltage delivery, resulting in the inability to power electrical modules or incomplete charging of the battery.

Classified by conductor size

Mainly types:

1,5mm² / 2,5mm² / 4,0mm² / 6,0mm² / 10,0mm² / 16,0mm² / 25,0mm² / 35,0mm².....

Part No.	Size (mm ²)	Conductor n×mm	Insulation Thickness mm	Jacket Thickness mm	OD of Jacket mm	Conductor resistance Ω/km	Current Carrying Capacity A
7194000	1.5	30×0.25	0.75	0.90	4.9±0.2	13.7	30
7194001	2.5	50×0.25	0.75	1.00	5.5±0.2	8.21	41
7194002	4.0	56×0.30	0.75	1.05	6.20±0.2	5.09	55
7194003	6.0	84×0.30	0.75	1.05	7.0±0.2	3.39	70
7194004	10.0	80×0.40	0.90	1.20	8.30±0.3	1.95	98
7194005	16.0	128×0.40	0.90	1.20	9.45±0.2	1.24	132
7194006	25.0	200×0.40	0.90	1.20	10.75±0.2	0.795	250

Solar wires are further classified based on the material used for the conductors. For both domestic and commercial installations, aluminum and copper solar wires are commonly utilized.

Copper wire exhibits superior conductivity compared to aluminum. A copper solar wire of the same size can carry a higher current load than an aluminum wire. Copper offers flexibility, better heat resistance, and versatility for both indoor and outdoor applications. However, copper wires tend to be more expensive.

Classified by shape

Single Solar cable / Twin Solar Cable



Figure: Single solar cable on the left and twin solar cable on the right

2.3.1.2 Wire insulation

Solar wires vary based on their insulation, which shields the cable from environmental factors like moisture, heat, chemicals, water, and ultraviolet (UV) light. Common insulation types include:

- ✓ THHN for dry indoor installations.
- ✓ TW, THW, and THWN for conduit applications in wet indoor or outdoor conditions.
- ✓ UF and USE (underground service entrance) suitable for wet, underground wiring, adaptable beyond underground uses.
- ✓ THWN-2 for indoor applications, less costly and running through conduit, not mandating UV resistance. Suitable for direct connection to the Main Service Panel, applicable for both DC and AC circuits, though sizing changes might be necessary after passing through the inverter.
- ✓ RHW-2, PV Wire, and USE-2 solar cables for moist outdoor applications, ideal for solar panel wiring, service terminal connections, and underground service entrances. PV wire and USE-2 cable jackets are UV resistant and moisture-resistant, with PV wire additionally featuring an extra insulation layer.

Wire color



Color-coded solar wires aid in implementing and mapping out the electrical wiring scheme. Each color denotes its specific purpose and function within the solar system. It also facilitates future troubleshooting and repairs. The National Electrical Code defines conductor insulations and their respective applications.

For Alternating Current (AC) and Direct Current (DC) applications, the color coding differs. Here's a simplified guide for electrical wiring installations:

For AC Applications:

- ✓ Red, black, or other colors denote ungrounded hot applications.
- ✓ White signifies the grounded conductor.
- ✓ Green or bare wires represent equipment grounding.

For DC Applications:

- ✓ Red indicates the positive pole.
- ✓ White designates the negative pole or grounded conductor.
- ✓ Green or bare wires signify equipment grounding.

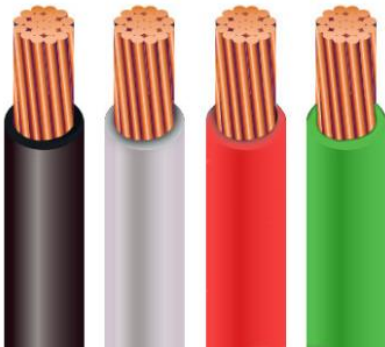

Figure: Color-coded solar wires

When installing electrical systems, adherence to the guidelines outlined in the National Electrical Code (NEC) is crucial. If uncertain about the suitable conductor and insulation for a specific application, seeking assistance from a certified electrician is advisable.

Wire rating and thickness

PV wires are rated based on their maximum amperage capacity. Solar panels generating higher amperage require thicker wires with a higher rating. It's essential to verify your system's amperage rating and utilize wire capable of handling the anticipated load. For instance, if your system produces 9 amps, select 9-amp or slightly higher rated wire (10 or 11 amps).





Figure: PV wires of different thickness, source: <https://www.kvcable.com/products/solar-cable/>

Selecting a solar wire with a lower rating can result in voltage drops, leading to overheating and potentially increasing the risk of fire. Generally, the thickness of the wire corresponds to its amp capacity. Always opt for wire that is adequately thick or slightly thicker to accommodate occasional power surges. Identify the appliance with the highest amperage and select a wire capable of handling that current. Online wire sizing estimators can assist in making informed decisions.

Wire length

In addition to wire rating and thickness, consider the wire's length. Longer wire distances result in increased electrical resistance and higher amperage consumption. It's advisable to use slightly thicker wire for added safety, especially for longer distances.

For instance, an installation spanning 5 meters with a maximum load of 10 amps and allowing a 3% acceptable cable loss could use a solar cable of 6mm. However, the same installation extending to 15 meters might require a thicker 25mm solar cable. Using wires with lower ratings increases the risk of voltage drop, overheating, and fire hazards. Electricians often recommend preparing for future load requirements, thus it's safer to use thicker wires during the initial installation.

2.3.1.3 DC solar cable

In a photovoltaic (PV) system, there are typically three types of cables utilized: DC solar cables, solar DC ground cables, and solar AC connecting cables.

Solar DC cables are available in modular or cabled configurations, usually consisting of single-core copper cables with insulation and protective sheathing. These cables come equipped with appropriate connectors and are integrated into photovoltaic solar panels during



manufacturing, making them unchangeable in most cases. At times, a DC solar cable might be necessary to link panels to each other.



Figure: A main DC cable source: <https://mrsolarchecheche.com/dc-solar-cables/>

Main DC cable

Main DC cables serve as larger power header cables, establishing connections between the positive and negative cables originating from the generator junction box and leading to the central inverter. Commonly used sizes for main DC cables include 2mm, 4mm, and 6mm solar cables.

Experts often prefer outdoor installations for DC cables. To prevent short-circuiting and grounding issues, it's advisable to run cables with opposing polarities away from each other.

Main DC cables can be either single-core or two-core. Single-core wires with dual insulation represent a reliable and practical solution. Meanwhile, for wiring purposes between the solar inverter and generator junction box, two-core DC cables are frequently chosen.

2.3.1.4 AC connecting cable

The AC connection cable links the solar inverter to the protective equipment and the power grid.

AC cables are used in solar systems but are less common. Typically, these cables connect the primary solar inverter to the household's electrical grid. In solar setups, 5-core AC cables are utilized, featuring three wires for the phases carrying the current, one wire to isolate the current from the device, and one wire for grounding/safety purposes, establishing a connection between the solar casing and the ground.

The size of the solar system often determines the type of AC cable required. Some systems may only necessitate 3-core cables. However, this is variable and not universally applicable

because different regions enforce distinct regulations, mandating compliance from professionals installing the cables.

Tip: For a PV system equipped with a single-phase inverter, it's recommended to use a three-core AC cable.



Figure: AC Cables Single Core, source: <https://www.valsa.co.za/pv-solar-products/pv-solar-cables/>

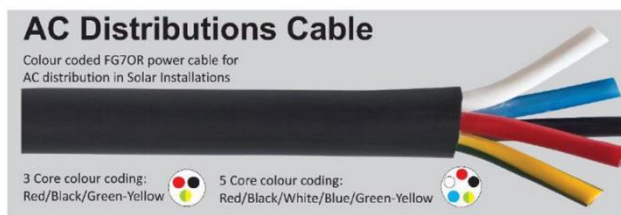

Figure: AC Cables 3 core and 5 core, source: <https://www.valsa.co.za/pv-solar-products/pv-solar-cables/>

2.3. Connecting elements and technology in photovoltaic system installation.

2.3.2 Solar Panel Connectors

In the past, solar modules were typically constructed with a junction box on the back, necessitating manual wire attachment to positive and negative terminal posts. While this method is still in use, it's gradually becoming obsolete. Modern solar modules increasingly employ MC4 connectors due to their simplicity and speed in wiring solar arrays.

MC4 connectors consist of male and female types designed to snap together, simplifying the installation process. Their locking mechanism ensures the connectors remain securely

plugged and well-suited for outdoor environments. Separating these connectors requires a specialized MC4 unlocking tool.

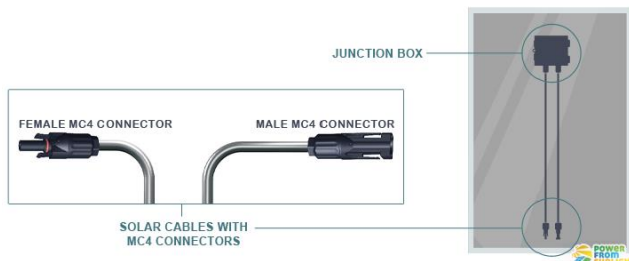

Figure: A junction box with two connectors, source: [www.power from sunlight](http://www.powerfromsunlight.com)

The term "MC" derives from "Multi Contact," the brand name of an American manufacturer, while the number 4 denotes the cross-section of the contact pin in mm².

The structure of an MC4 solar connector resembles that of a socket, comprising a female and a male component.

For optimal performance, double-insulated solar cables are recommended. These cables possess an additional black coating providing protection against UV light exposure. Consequently, they are resilient against sunlight and weather, safeguarding against heat, moisture, and temperature fluctuations.

When using MC4 solar connectors, it's essential to ensure the solar cables have a suitable diameter. An inappropriate cable diameter might result in an inadequately closed connection.

2.3.2 Solar Panel Connectors

MC4 solar connectors offer the advantage of easy hand assembly while ensuring a secure connection. Once joined, the plug connection can only be released with a suitable tool. This prevents accidental disconnection, such as when pulling on a solar cable.



Figure: Male MC4 and Female MC4 connectors source: <https://www.solar-electric.com/learning-center/how-to-use-mc4-connectors-cables.html/>

When using MC4 solar connectors, it's crucial to match solar cables with the appropriate diameter for a properly closed connection. An incorrect cable diameter might lead to an insecure connection.

Typically, in a DC circuit, the female MC4 connector corresponds to the positive lead while the male connector corresponds to the negative lead. However, this arrangement might vary, so it's advisable to confirm the polarity by checking markings on the junction box or using a digital voltmeter.

Unlocking Tool For MC4 Cable Connectors

Unplugging MC4 connectors once they're locked together can be challenging. To facilitate unplugging, a specific tool is recommended. If you only need to unplug MC4 cables, a single tool suffices.



Figure: Unlocking Tool For MC4 Cable Connectors
source: <https://www.solarelectric.com/ditoformc4co.html>

However, for separating and screwing them back together (as depicted in picture), two tools are necessary.

2.3.2.1 Series connection of PV modules equipped with MC4

In a series connection of PV modules equipped with MC4 connectors, the positive lead (male connector) from one module is connected to the negative lead (female connector) of another module. This interconnection forms a chain, where the male connector snaps directly into the female connector of the adjacent module. Here's a simple diagram illustrating this.

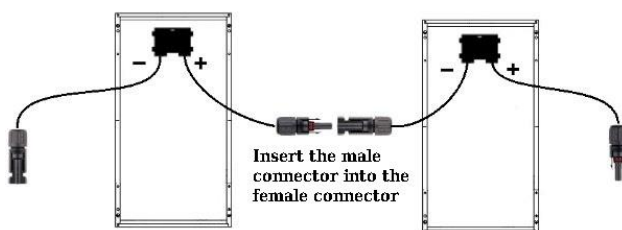

Figure: Series connection diagram of PV modules equipped with

MC4 source: <https://www.solar-electric.com/learning-center>

As you can see from the figure.

Connecting solar modules in series leads to an increase in the overall circuit voltage while maintaining a consistent current at maximum power (I_{mp}) throughout the series circuit.

When you connect two solar modules in series, the total voltage of the circuit adds up. For instance, if each module is rated for 18 volts at maximum power (V_{mp}), connecting them in series results in a combined voltage of 36 V_{mp} (18 volts + 18 volts). Similarly, if three modules are connected in series, the total V_{mp} will be 54 volts (18 volts + 18 volts + 18 volts).

However, it's important to note that while the voltage increases in a series connection, the current at maximum power (I_{mp}) remains constant. The current is determined by the lowest current produced by a single module within the series configuration. This relationship is crucial to consider when designing or configuring solar panel arrays for specific applications.

2.3.2.2 Wiring MC4 Equipped Modules in Parallel

When wiring solar modules in parallel, the positive leads are connected together, and the negative leads are also connected together. This setup increases the total current at maximum power (I_{mp}) while maintaining a constant voltage. For instance, if each module is rated for 8 amps I_{mp} and 18 volts V_{mp} , connecting two of them in parallel results in a total current of 16 amps I_{mp} while the voltage remains at 18 volts V_{mp} .

For the parallel connection of two modules, using MC4 multibranch connectors is an efficient method. These connectors facilitate the connection by reducing the number of wires from two positive and two negatives to one positive and one negative. Multibranch connectors come in two types: one type accepts two male MC4 connectors on the input side and has a male MC4 connector for its output, while the other type accepts two female MC4 connectors and has a female MC4 connector for its output.

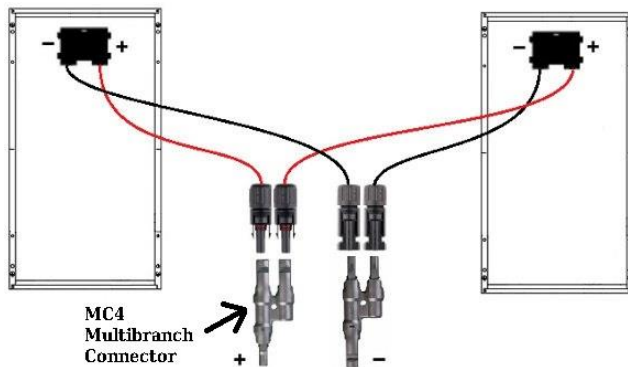

Figure: Parallel connection diagram of two PV modules equipped with MC4 source: <https://www.solar-electric.com/learning-center>

However, if you're paralleling more than two modules or strings of modules, a PV combiner box becomes necessary. A combiner box eliminates the need for multibranch connectors, as it performs the same function on a larger scale. It's important to note that multibranch connectors are only suitable for paralleling two modules together. When connecting more than two modules or strings in parallel, a combiner box is the appropriate choice. The number of modules that can be combined using a combiner box depends on its electrical rating and physical size.

Whether using multibranch connectors or a combiner box to combine modules, understanding how to select and use MC4 extension cables is crucial for proper installation and configuration in a solar setup.

2.3.2.3 MC4 Extension Cable and How do I use them?

An MC4 extension cable functions similarly to an electrical extension cord. Much like an extension cord, which has a male plug on one end and a female plug on the other, an MC4 extension cable features a male connector on one end and a female connector on the opposite end. These extension cables come in various lengths, ranging from 6 meters to 30 meters.

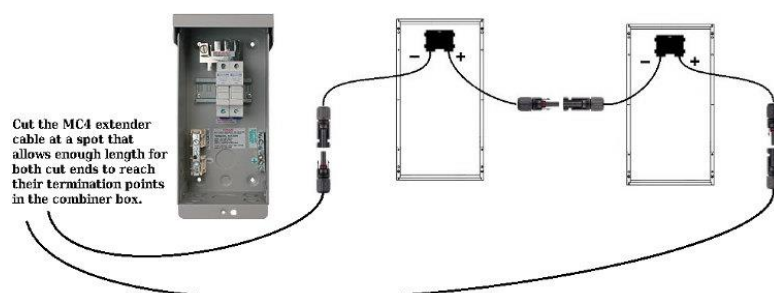

Figure: This diagram shows you an example connection of an MC4 extension cable
source: <https://www.solar-electric.com/learning-center/how-to-use-mc4-connectors-cables.html/>

For instance, in the scenario of wiring two modules in series, after connecting the two modules in series, you'll need MC4 cables to transport that generated power to where your electrical components are typically located. In applications like RVs and boats, where systems often use two modules, you can usually employ extension cables to cover the entire distance required.

However, when it comes to installing solar panels in homes or cabins, the distance the wire must traverse is usually too extensive for practical use of extension cables alone. In these situations, extension cables are utilized to connect the panels to a combiner box. This approach allows for the use of less expensive wiring, such as THHN-rated insulation, within the electrical conduit, covering longer distances at a significantly reduced cost compared to using MC4 cables throughout the entire span.

2.4. The inverter's role, functional capabilities, and the different types.

2.4.1 The Inverter- Introduction

An inverter serves as a crucial component in a solar photovoltaic system by converting the direct current (DC) produced by solar panels into alternating current (AC) with a fixed frequency and consistent voltage, typically 220V at 50Hz sine wave. The primary purpose of the inverter is to make solar-generated energy usable for various appliances in homes or to feed it back into the electrical grid.



Figure: The solar inverter, source: <https://www.cleanenergyreviews.info/blog/2015/5/28/solar-and-hybrid-inverter-introduction>

Apart from this fundamental function, inverters also offer additional essential features, notably online monitoring of the PV system's performance. These inverters can connect to the internet, allowing users to access real-time data regarding their system's energy production

and consumption. This access proves invaluable for monitoring energy usage compared to utility bills and ensuring the system operates optimally.

Inverters are rated in kilowatts (kW), slightly lower than the kilowatt-peak (kWp) rating of the solar array. This is to optimize efficiency since inverters generally perform better when operating close to their maximum power capacity, whereas the solar array may not always be at peak power output.

Another crucial role of the inverter is to manage the optimal operational mode of the PV panel system. Thus, selecting an appropriate location for installation that ensures easy access becomes important.

In summary, the inverter performs two primary functions:

Maximizing energy yield from photovoltaic panels. Converting DC from the panels into AC for household use or exporting to the national grid. Furthermore, modern inverters often come with internet connectivity, enabling remote monitoring via apps or web browsers. This technology not only allows users to monitor their systems remotely but also increases awareness of energy usage, promoting sustainability and potential cost savings.

2.4.2 Components of Solar Inverters

What components are solar inverters made of?

Solar inverters consist of several essential components that enable the conversion of direct current (DC) generated by solar panels into alternating current (AC) for use in homes or the grid. Here are the key components and functionalities typically found in solar inverters:



Figure: A photo of the device and elements of an inverter. source: <https://sinovoltaics.com/learning-center/inverters>

- 1. Switching Components (Field-Effect Transistors - FETs, Triacs, Bipolar Transistors with IGBT):** These components are crucial for the switching function within the inverter. Field-effect transistors (FETs) are commonly used due to their low conduction losses in switching mode. Bipolar transistors with insulated-gate bipolar transistors (IGBT) are found in some designs as well.
- 2. Filtering Components (Inductors and Capacitors):** Inductors and capacitors are used to filter the output of the inverter, ensuring that the produced AC power is clean and without distortions.
- 3. Control of Amplitude, Frequency, and Phase:** Inverters manage the amplitude, frequency, and phase of the output AC power. The process involves adjusting these parameters to match the required specifications for grid-tied inverters.
- 4. Maximum Power Point Tracking (MPPT):** Some inverters incorporate MPPT functionality, optimizing the solar panel's output by tracking the point of maximum power.
- 5. Conversion to Mains Frequency and Filtering:** For pure sine wave inversion, the inverter converts DC to high-frequency AC and then back to mains frequency while filtering the output. Sine Wave Pulse Width Modulation (SPWM) is used to achieve a pure sinusoidal waveform.
- 6. Control Circuit and Microcontroller:** Control circuits, often managed by microcontrollers, regulate the PWM and other functions within the inverter.
- 7. High-Frequency Switching and Transformers:** High-frequency switching allows for the use of lighter transformers, reducing overall weight. Transformers provide isolation to ground on the load side and the panel side but add significant weight to the inverter.
- 8. Transformerless Designs:** Modern transformerless inverters are gaining popularity due to their reduced weight and improved efficiency (by approximately two percent) compared to inverters with transformers. These designs eliminate the need for a transformer, enhancing efficiency and reducing weight.

These components collectively enable the solar inverter to efficiently convert DC power from solar panels into AC power suitable for home consumption or grid integration while ensuring optimal performance and compatibility with various applications.

2.4.3 Types of solar inverters

Solar inverters come in various types, each with its unique features and benefits catering to different installation needs. Here's an overview of different types of solar inverters:

String Inverters: These are the traditional and most common type of inverters used in solar installations. They manage the power conversion for a string of solar panels connected in

series. They are cost-effective and work well when there is minimal shading or when all panels are oriented in the same direction.

Microinverters: Unlike string inverters, microinverters are installed individually on each solar panel, converting the DC power generated by each panel into AC. This design allows each panel to operate independently, maximizing the system's overall performance, especially in shaded conditions. They also enable precise monitoring of individual panel performance.

Optimized String Inverter: Similar to standard string inverters, these inverters incorporate power optimizers installed under each solar panel. Power optimizers act as "smart panels," monitoring and communicating each panel's performance independently. This setup optimizes the overall system efficiency, similar to microinverters but with a different architecture.

Hybrid Inverter: Hybrid inverters combine PV (photovoltaic) inverter functionalities with battery inverter capabilities. They are designed to manage solar panels, batteries, and the utility grid simultaneously. These inverters are popular among homeowners interested in backup power solutions as they make integrating batteries more cost-effective.

Hybrid inverters are a comprehensive solution that can efficiently handle power from solar panels, batteries, and the grid. They provide versatility and intelligent management of energy sources, making them an increasingly common choice for those seeking a more integrated and flexible energy system.

Each type of solar inverter has its advantages, making them suitable for different scenarios, preferences, and installation requirements. Choosing the right type depends on factors like shading, panel orientation, monitoring needs, and the desire for battery integration.

2.4.3.1 Circuit symbols and functionality

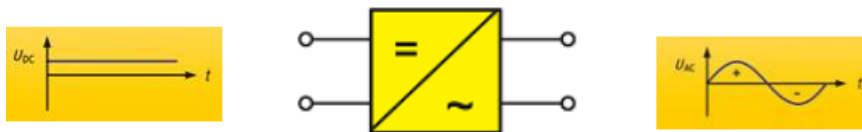

Figure: Inverter circuit symbol

the circuit symbol depicted in the figure represents an inverter, which is essentially a device used to convert direct current (DC) into alternating current (AC). Modern power electronics allow this conversion with minimal losses, making inverters integral in various applications.

Inverters can be categorized into two primary groups based on their purpose and usage:

Grid-Tied Inverters (Grid Inverters): These inverters are specifically designed to connect with the public power grid. In grid-connected PV systems, the inverter facilitates the direct connection of solar-generated electricity to the grid. This allows surplus power generated by the solar panels to be exported to the grid, offsetting utility-provided electricity or even earning credits through net metering schemes.

Stand-Alone Inverters: Stand-alone inverters are used in systems that operate independently, without a connection to the main power grid. They are commonly employed in off-grid or remote areas where there is no access to utility-provided electricity. Stand-alone inverters allow the use of conventional AC loads in these setups, enabling appliances and equipment to operate using power converted from solar panels or other DC sources, such as batteries or wind turbines.

In the case of grid-connected systems, inverters can also be integrated with home grids. This allows the electricity generated by solar energy to be consumed within the household premises first. Any excess power not used by the home's electrical loads is then supplied to the public electricity grid, contributing to the overall grid supply.

The choice between grid-tied and stand-alone inverters depends on various factors, including the location of the system, the availability of the main power grid, desired energy independence, and the specific needs and goals of the user or installation.



Figure: Depending on the mission of each inverter, a distinction is made between inverters that are connected to grid systems (grid inverters) or in stand-alone systems (stand-alone inverters). source: <https://www.cleanenergyreviews.info/blog/what-is-a-hybrid-inverter>

Inverters can be broadly classified into two types: Voltage Source Inverter (VSI) and Current Source Inverter (CSI). This classification is based on the input source i.e. whether the input source is voltage source or current source (see figure).

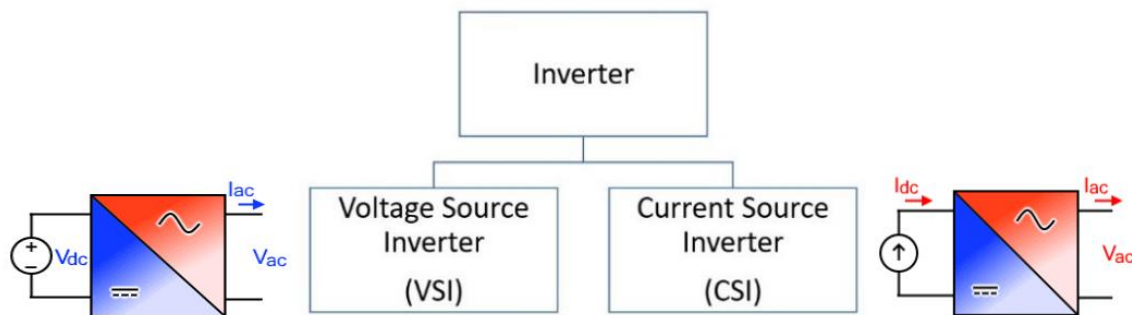

Figure: Scheme of a voltage source inverter (VSI) and a current source inverter (CSI)

Solar inverters perform the following functions:

- ✓ Conversion of the direct current generated by the PV generator into a grid-compliant alternating current
- ✓ Adaptation of the operating point of the inverter to the MPP of the PV generator (MPP control);
- ✓ Operational data acquisition and signaling (e.g. display, data storage, data transmission);
- ✓ DC and AC protective device (e.g. reverse polarity protection, overvoltage and overload protection, monitoring and protective devices to comply with the VDEW guidelines for in-house generation systems);
- ✓ Grid monitoring, if necessary grid management (e.g. reactive power generation)

2.4.3.2 String inverters

A string refers to a chain of panels connected in series. String inverters are the most prevalent type, earning their name from the wiring of solar panels in 'string circuits' linked to the inverter. This configuration represents the most fundamental inverter system. For optimal efficiency, all panels within a string must share the same tilt and orientation. Many string inverters feature 2 or even 3 MPPTs (Maximum Power Point Tracking), allowing different strings of panels to connect to each MPPT. Typically, higher-capacity inverters accommodate a greater number of string circuits. For instance, a 10-kW inverter may have 2 or 3 circuits, while a 60-kW inverter might include 12.

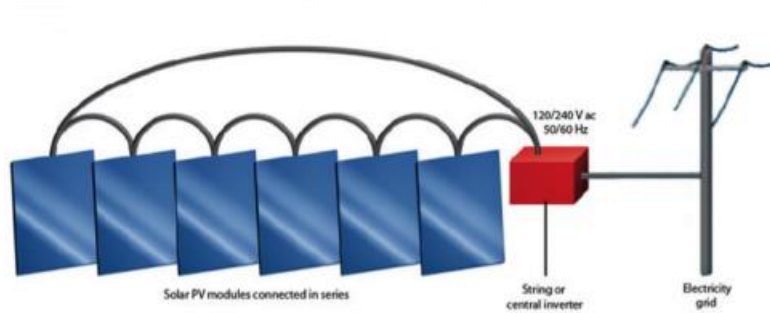

Figure: A solar string inverter system, source: <https://www.powerfromsunlight.com/important-facts-solar-string-inverter/>

2.4.3.3 Microinverters

Microinverters, on the other hand, are small devices that directly link to solar panels, bypassing the need for a central string inverter. Unlike power optimizers, which don't perform conversion, microinverters convert DC to AC power right at the panel. Consequently, they eliminate the necessity for a string inverter. Additionally, due to their panel-level conversion, if one or more panels are shaded or underperforming, the remaining panels' efficiency remains unaffected. While string inverters display the performance of each string, microinverters monitor the performance of each individual panel. This makes microinverters ideal for installations facing shading issues or incorporating panels on multiple planes with different orientations. Although microinverter systems can be more efficient, they often come with a higher cost. It's important to note that the installation of an inverter on each panel increases both installation costs and time. Maintenance for these systems is also more intricate - having 300 solar panels would mean managing 300 microinverters.

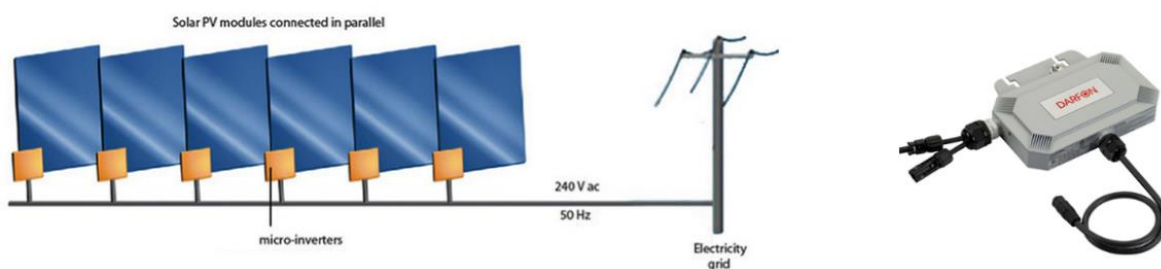

Figure: A micro-inverter based PV system, source: <https://mk2i.hk/Optimisers-vs-microinverters/>

Despite their drawbacks, microinverters have emerged as excellent options for residential and business solar applications. Initially, their cost was a significant barrier, but recent advancements have made them more affordable.

Presently, numerous panel manufacturers provide microinverters integrated into the panel, akin to smart modules, referred to as AC modules. This integration simplifies and reduces installation costs. Presently, numerous panel manufacturers provide microinverters integrated into the panel, akin to smart modules, referred to as AC modules. This integration simplifies and reduces installation costs.

2.4.3.4 Optimized inverter system

A hybrid technology merging microinverters and string inverters delineates the responsibilities of an inverter. Behind each panel, optimizers manage Maximum Power Point Tracking (MPPT) duties, effectively isolating any shading or fault issues. These optimizers link to a central inverter, which can operate more efficiently due to a consistent voltage supply from the panels (unlike string inverters that contend with varying voltages). Additionally, these systems are internet-connected, enabling proactive maintenance. In case of a fault, your installer receives an email alert, facilitating a prompt and accurate response.

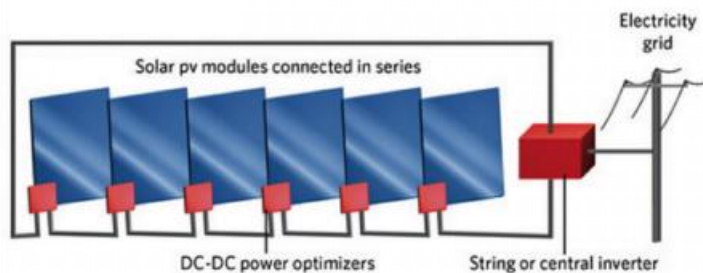

Figure: The optimized inverter system is a hybrid of microinverters and string inverters, source: <https://mk2i.hk/Optimisers-vs-microinverters/>

The generated power is transmitted at high DC voltage (typically 200-500VDC), while the typically wall-mounted inverter performs the DC to AC conversion. This setup provides the advantages of panel-level optimization alongside cost savings from using a single string inverter.

2.4.3.5 Inverter battery for home or off-grid inverter

Most off-grid solar systems charge their own batteries. However, these systems face difficulties in charging batteries during winter or under heavy shading.

This home inverter type is bi-directional, serving as both a battery charger and an inverter. It can be utilized in off-grid, grid-connected, or grid-interactive setups at home. This system necessitates an alternator to initiate the conversion between AC and DC.

These inverters are commonly referred to as off-grid inverters, although this label can be somewhat misleading: they cannot establish an off-grid system without batteries. For this purpose, a hybrid or grid-tie inverter is required. Their primary function is converting DC current from batteries into usable AC current. They cannot directly power loads from solar panels, hence the term 'battery inverters'. If either the battery or charge controller fails, the entire system ceases to operate, even if the PV modules function perfectly. Despite these limitations, off-grid systems utilizing these inverters are simple and cost-effective. This makes them an ideal choice for mobile applications like powering boats or RVs.

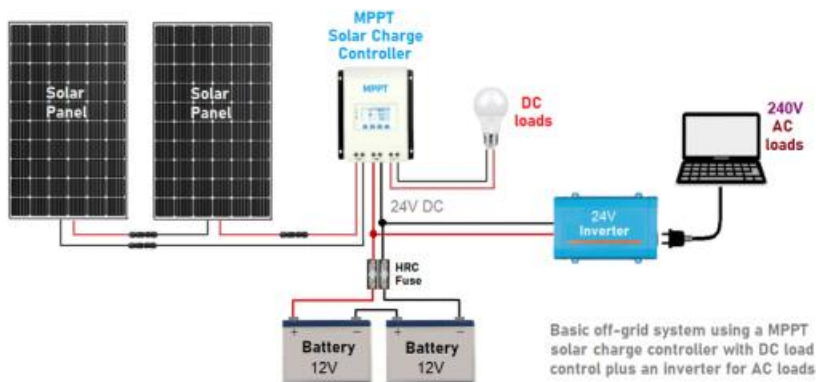

Figure: Small scale off-grid system with a single MPPT solar charge controller and small battery inverter. source: <https://www.cleanenergyreviews.info/>

Small-scale off-grid solar systems and DIY setups in caravans, boats, small homes, and cabins use MPPT solar charge controllers, also known as solar regulators. These controllers are installed between the solar panel/s and battery to ensure proper battery charging, preventing overcharging. Most small 12V/24V solar charge controllers feature load output terminals often used for basic DC lighting circuits. In small DIY systems, simple 'plug-in' style inverters are employed to provide 240V or 120V AC power. These inverters come in various sizes, ranging from tiny 150W inverters to 3000W or higher.

2.4.3.6 Central inverters

Central inverters, similar to string inverters but on a larger scale, can accommodate more strings of panels. Unlike string inverters where strings directly link to the inverter, in central inverters, the strings are combined in a central combiner box. The DC power from this combiner box is then directed to the central inverter where it undergoes conversion into AC power. While central inverters require fewer component connections, they necessitate a pad and a combiner box.

This setup involves connecting the generated DC power from several series of solar panels in parallel at a combiner box. The combined DC output from the combiner box is then directed to a single central inverter. The rated Maximum DC input power (P_{dcmax}) for these inverters typically ranges from 50 to 1MWp

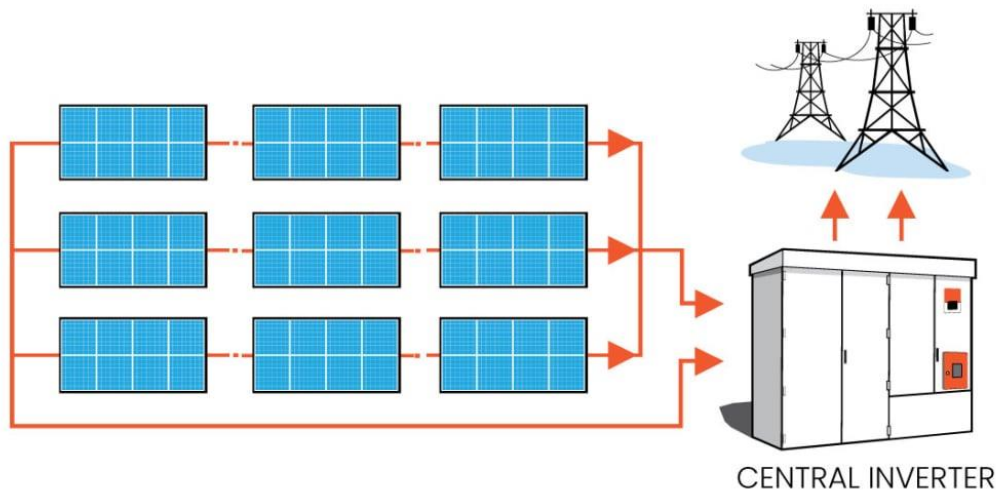

Central Inverter

Figure: Schematic connection of one central inverter, source: <https://sinovoltaics.com/learning-center/inverters>

2.4.3.7 Hybrid inverter

Traditional inverters are primarily designed for one-way power flow—from solar panels to the building and, when applicable, sending excess electricity to the grid. However, with the integration of battery systems in many solar setups, the operation becomes more intricate as electricity can now move in various directions. Some instances include:

- ✓ From solar panels to the building
- ✓ From solar panels to batteries
- ✓ From solar panels to the power grid
- ✓ From batteries to the building
- ✓ From batteries to the power grid
- ✓ Simultaneously from solar panels and batteries to the building

A conventional string inverter isn't equipped to handle these diverse power flows; hence, a hybrid inverter is necessary to utilize solar power alongside energy storage.



The hybrid inverter, a multi-mode system, requires both battery and inverter installations. Apart from supplying DC power to the batteries, a solar hybrid inverter also delivers AC electricity to the grid and household appliances. Enabled with Maximum Power Point Tracking (MPPT), it monitors the power required by the batteries and optimizes their charge, considering grid electricity costs.

Once the battery reaches full charge, surplus power can be directed back to the grid via a charge controller. Rather than shutting down completely, these home solar inverters can switch to standby mode in case of any system issues.

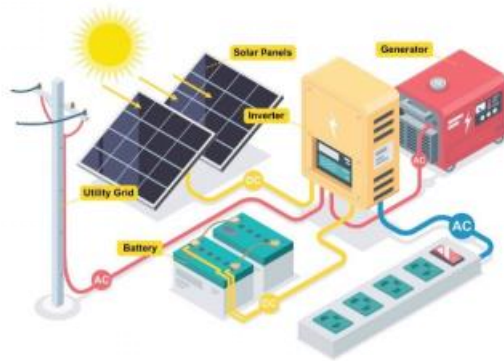

Figure: A hybrid Inverter, source: <https://palmetto.com/learning-center/blog/hybrid-inverter-for-solar-guide-pros-cons>

Hybrid inverters often feature integrated monitoring tools, offering comprehensive insights into system performance. This functionality allows users to track how much solar-generated electricity is consumed within the building, stored in the battery system, and exported to the grid.

2.4.3.8 Single-phase and three-phase inverter

Most residential homes typically utilize a single-phase power supply, while three-phase power is more common in industrial settings due to its capacity to transfer higher power levels, effectively powering large machinery, heaters, electric car chargers, among other heavy-duty equipment. The power transfer in alternating current (AC) occurs at a frequency of 50 - 60 Hz. Transmission lines usually feature multiples of three lines to support three-



phase power transfer. In three-phase systems, power transmission involves three different currents that are phase-shifted from one another.

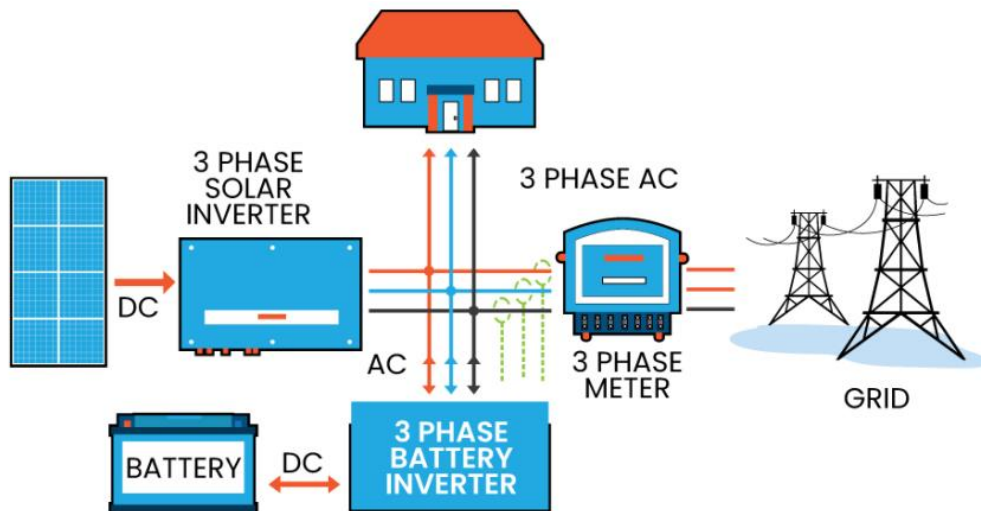

Figure: Three phase solar inverter, source: <https://sinovoltaics.com/>

What are the main differences between single-phase and three-phase inverters?

A single-phase inverter generates single-phase power from PV modules and connects to either single-phase equipment or the grid. There are two types of single-phase inverters: full bridge inverters and half bridge inverters.

Conversely, a three-phase inverter produces three-phase power from PV modules and can be connected to three-phase equipment or the grid. It converts the DC input from solar panels into three-phase AC output. The three phases of the output are typically delayed by a 120° angle to generate the 3-phase AC supply. While a three-phase inverter is preferred for installations with a three-phase power source, a single-phase inverter is more commonly used and suitable for single-phase sources.

Using a three-phase inverter enables the generation of greater power for direct use and facilitates sending substantially more solar energy back into the grid compared to a single-phase system.

2.4.3.9 Type of Solar Inverters - Diversity and Examples

Numerous companies and commercial platforms annually conduct rankings to highlight the most popular and best-selling inverters in various regional solar markets worldwide.

Below, we present an example of such an evaluation, emphasizing that this assessment remains non-binding and represents just one of many similar studies available online. It's

essential to note that these evaluations lack definitive claims regarding evaluation criteria and the thoroughness of the analysis conducted by the respective companies.





Inverter evaluation criteria



To determine the current top-performing solar inverters, the assessment incorporates continuous feedback gathered from solar installers and industry professionals. Primarily, the comparison focuses on regular grid-connected (single-phase) solar inverters. However, hybrid inverter models, designed for the growing demand in battery technology, are also considered.

While efforts are made to include a broad range of inverter models, it's important to acknowledge that some newer brands might not be featured due to factors such as limited installer feedback, insufficient real-world performance and reliability data, or lower exposure in the market from the manufacturers.

Quality and reliability; Service and support; Monitoring; Warranty; Characteristic; Price

Picture	Make	Model	Sizes (kW)	Warranty	Key Features	Price EURO
	<u>Fronius</u>	Primo	3,4,5,6,8.2	10 Year	Snap-in design, Hidden connections, LCD display, Dynamic shade function, Austrian made	850÷÷1600

Picture	Make	Model	Sizes (kW)	Warranty	Key Features	Price EURO
	<u>SolarEdge</u>	HD Wave	3,4,5,6,8,10	12 Year	DC Optimisers , panel level monitoring	950÷÷1730
	<u>Huawei</u>	SUN2000 L1	3,3.6,4,5,6	10 Year	Hybrid inverter, optional DC optimisers	817÷÷1078
	<u>SMA</u>	Sunny Boy	3,3.6,4,5,6	5+5 Year*	German made, Shadefix setting	784÷÷1200
	<u>Sungrow</u>	UNO DM PLUS	2,2.5,3,5,8	10 Year	LCD Display, very high efficiency	580÷÷980

Picture	Make	Model	Sizes (kW)	Warranty	Key Features	Price EURO
	<u>FIMER</u>	UNO DM PLUS	3,3.3,4.6,5	10 Year	High MPPT current for Parallel strings	955÷÷1740
	<u>Goodwe</u>	DNS Series	3,3.6,4.2,5,6	5 Year*	LCD Display, shadow scan setting	450÷÷620
	<u>DELTA</u>	Home Series	2.5,3,4,5	5 Year*	Very low startup voltage, high efficiency	620÷÷882

source: <https://www.cleanenergyreviews.info/blog/best-grid-connect-solar-inverters-sma-fronius-solaredge-abb>

The indicated prices should be considered as indicative only and strongly depend on regional specifics.

Detailed inverter comparison charts

Clicks the links below to see our detailed inverter comparison charts

Solar Inverters - Single phase: <https://www.cleanenergyreviews.info/solar-inverter-comparison>



Co-funded by
the European Union

Funded by the European Union. Views and opinions expressed are however those of the author(s) only and do not necessarily reflect those of the European Union or the European Education and Culture Executive Agency (EACEA). Neither the European Union nor EACEA can be held responsible for them.

Hybrid Inverter - Single-phase: <https://www.cleanenergyreviews.info/hybrid-solar-inverter-comparison>

Hybrid Inverters - 3-phase: <https://www.cleanenergyreviews.info/3-phase-hybrid-solar-inverters>

Off-grid Inverter-chargers: <https://www.cleanenergyreviews.info/solar-hybrid-off-grid-inverter-comparison>

2.4.3.9. Type of Solar Inverters - Diversity and Examples

While this article is primarily focused on the leading residential, single-phase string solar inverters, most manufacturers also produce a range of inverters designed for larger 3-phase residential and commercial applications. String solar inverters up to and above 100kW are also increasingly popular for use in utility-scale solar farms due to the advantages of string level monitoring and ease of servicing compared to single central inverters. Below is our list of the most popular 3-phase inverters on the market in the 8kW to 30kW, and 30kW to 100kW categories.

Best 3-phase solar inverters - 8kW to 30k

Fronius - SYMO and ECO



FRONIUS SYMO

Symo 3.0-3-M → Symo 20.0-3-M



FRONIUS ECO

Eco 25.0-3-S Eco 27.0-3-S

Sungrow - SG & CX range

SolarEdge - SE 3-phase



Co-funded by
the European Union

Funded by the European Union. Views and opinions expressed are however those of the author(s) only and do not necessarily reflect those of the European Union or the European Education and Culture Executive Agency (EACEA). Neither the European Union nor EACEA can be held responsible for them.

Commercial Three Phase Inverter
(82.8K & 100K model)



Commercial Three Phase Inverter
(50, 55K & 66.6K model)



Huawei - SUN2000-KTL range



SMA - Sunny Tripower range



Best 3-phase solar Inverters - 30kW to 100kW+



Co-funded by
the European Union

Funded by the European Union. Views and opinions expressed are however those of the author(s) only and do not necessarily reflect those of the European Union or the European Education and Culture Executive Agency (EACEA). Neither the European Union nor EACEA can be held responsible for them.

1. **Sungrow - CX range**
2. **Huawei - SUN2000-KTL range**
3. **SMA - Sunny Tripower Core 1**
4. **FIMER - PVS-TL range**
5. **SolarEdge - SE range**

Note: The above company analysis should be considered only as a snapshot of the rapidly changing inverter market.

2.5. Solar batteries. 2.5.1. Introduction.

2.5.1 Introduction. Why are solar batteries needed in a photovoltaic system?

Solar batteries serve as essential components within a photovoltaic system by storing surplus energy generated by solar panels. This stored energy becomes instrumental in powering your home during cloudy, rainy days, or after sunset.

In the absence of a mechanism to store the energy produced by solar panels, solar power utilization becomes inefficient. Appliances can only operate when sunlight is available, and the panels are actively producing electricity. Unused energy at the moment of generation goes to waste, unavailable during nighttime hours. Solar batteries resolve this by storing excess energy from the panels for use when needed. They complement or supplement feeding power back to the grid, enhancing household or facility independence during power outages and, in some cases, facilitating a complete disconnection from the grid.

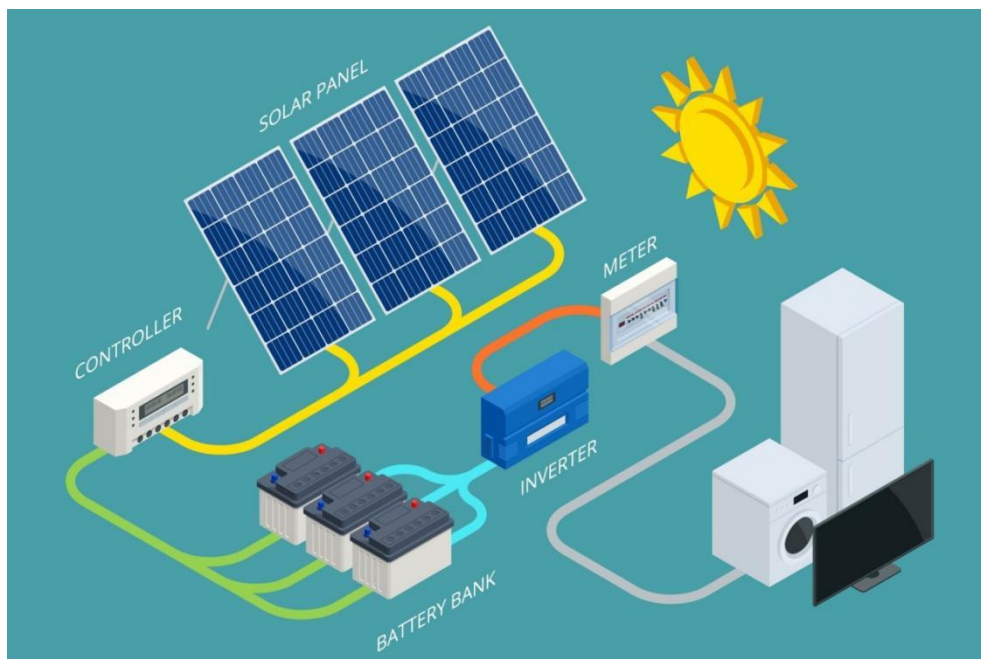

Figure: A photovoltaic autonomous system with a battery bank, source: <https://sunlightsolar.com/how-do-solar-batteries-work/>

Typically, a household might utilize 35% to 50% of the generated system power without a battery. This utilization may increase if the house is occupied for extended periods during the day. However, integrating battery storage can elevate this utilization to 80%. If your PV system fully consumes all generated energy and you have no surplus, battery storage might not be necessary. Yet, if excess energy is available, integrating batteries can further reduce your energy bill effectively.

It's worth noting that modern battery systems prioritize household loads before charging the battery. However, some systems allow users to customize load priorities according to their preferences.

2.5.2. Solar Battery Types -Lead-Acid Battery

Solar power systems rely on four primary types of batteries: lead-acid, lithium-ion, nickel-cadmium, and flow batteries.

Lead-Acid Battery

These batteries have been extensively utilized for decades, prominently in automotive and industrial applications. They possess a relatively low energy density, indicating a lower energy storage capacity per kilogram. Despite this, they remain cost-effective and dependable, making them a popular choice for residential solar setups. Available in flooded and sealed variants, lead-acid batteries are categorized as shallow cycle or deep cycle based on their intended use and safe depth of discharge (DOD). Recent technological advancements have extended their lifespan, solidifying lead-acid batteries as a viable choice for numerous homeowners.





Figure: LED acid tall tubular solar batteries, source: <https://kenbrooksolar.com/solar-battery>

Presently, the lead-acid tall tubular battery represents a proven, time-tested, and reliable solar battery technology. It's an enhanced iteration of standard batteries optimized for home solar panel usage. These C-10 rated batteries are specifically tailored to cater to diverse solar applications.

Lead-acid tall tubular batteries require periodic water top-ups every 3 to 6 months and boast superior energy storage capabilities compared to other battery types.

These deep-cycle solar tubular batteries have undergone rigorous testing and are suitable for deployment in off-grid solar systems, hybrid solar setups, and solar home lighting systems

Lead-acid batteries

Advantages	Disadvantages
High-efficiency batteries	Tall tubular batteries are heavy
More than 1500 life cycles	You need to refill these batteries timely
5 to 7 years long working life	More space is required compared to lithium-ion batteries
Cost-effective	
Easy to maintain, install, and access	
No need of heavy maintenance	
Very low repair/maintenance cost	

2.5.2 Solar Battery Types - Lithium-ion solar battery



Lithium-ion batteries are widely used in solar applications due to their high current rating and extended cycle life. Among their key advantages is their remarkable longevity, capable of enduring up to 5000 cycles, enabling efficient energy utilization from solar panels.

Solar Battery Types

Nickel-Cadmium solar battery

Nickel-iron (NiFe) batteries are primarily utilized in off-grid systems, especially when high capacities and discharge rates are essential. Ni-Cd batteries exhibit exceptional resilience, withstanding overcharging, undercharging, and freezing conditions, ensuring longevity and enduring numerous cycles.

They offer protection against inadvertent deep discharges and are ideally suited for daily cycling in off-grid battery banks.

NiFe battery packs are typically designed for an 80% depth of discharge (DOD), allowing for the use of smaller battery packs.

Nickel-cadmium batteries (Ni-Cd) are rechargeable batteries known for their ability to be deeply discharged and their extended service life. They perform reliably even at low temperatures, maintaining good performance levels. Ni-Cd cells typically have a nominal cell potential of 1.2 V.





Figure: Nickel-cadmium batteries, source: <http://www.ariapower.com/nickel-cadmium-batteries/>

Unlike lead-acid batteries, it's challenging to monitor the state of charge (SOC) of Nickel-Cadmium (Ni-Cd) batteries using a voltmeter or hydrometer, complicating the assessment of their condition. Ni-Cd batteries are more expensive than lead batteries.

Additionally, Ni-Cd batteries are susceptible to the "memory effect." Without proper maintenance involving periodic full discharges, these batteries tend to retain the memory of previous discharges, which limits their recharge life.

Another consideration is that Ni-Cd batteries require a charger with higher voltage compared to one used for lead-acid batteries. Charging efficiency for Ni-Cd batteries is typically lower, averaging between 70-75%.

Nickel-iron batteries boast a long service life of over 40 years, but they have high initial costs, higher self-discharge rates, and require periodic maintenance.



Although Ni-Cd batteries are rarely employed in residential settings, they are popular in airline and industrial applications due to their durability and ability to function in extreme temperatures. These batteries also necessitate relatively low maintenance compared to other types.

One significant drawback of Ni-Cd batteries is the use of cadmium, a highly toxic element. Improper disposal of cadmium can significantly harm the environment.

Nickel-Cadmium solar battery

Advantages

Disadvantages

Long service life (10,000+ cycles)

Durability (can be recharged and deep discharged)

Resistant to freezing, even if diluted.

Large acceptable operating temperature range
(approximately -20°F to 190°F)

Best among daily discharge/charge systems (non-
floating)

High price

Moderate efficiency (80%)

Need for water and ventilation

High rate of self-discharge (30%
per month)



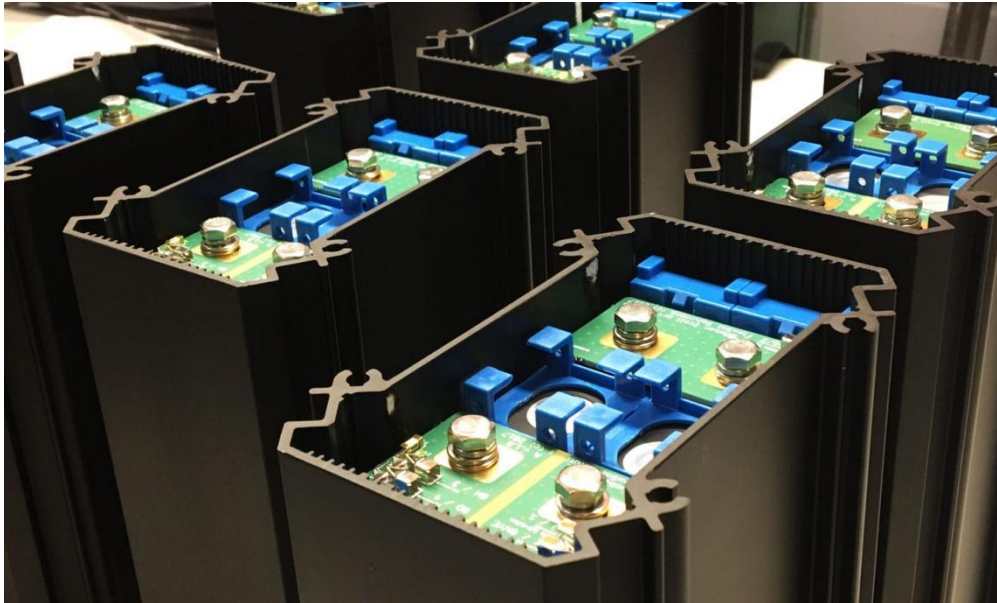

Figure: A lithium iron phosphate (LiFePO₄) battery

source: <https://flexsolutions.com/soluxio/advantages-lithium-batteries/>

The lithium iron phosphate (LiFePO₄) battery stands out as the optimal lithium-ion variant for solar power applications. LiFePO₄ batteries offer complete safety, non-flammability, stability for 15 to 20 years, and require minimal maintenance.

Additionally, these batteries exhibit superior electrical performance and low resistance, making them a preferred choice across various solar applications, including integrated solar street lights and solar-powered vehicles.

With ongoing advancements, lithium-ion batteries are available in diverse sizes, ranging from modular configurations starting at 1.2 kWh and extending up to 10 kWh batteries.

Despite the advantages of lithium-ion batteries, lead-acid batteries still hold relevance, especially in off-grid applications, providing a cost-effective solution, particularly for irregular usage scenarios.

All batteries benefit from a battery manager, significantly prolonging their lifespan. In the case of Li-Ion batteries, this functionality is often integrated. Compatibility between the battery and any inverter/charger unit is crucial for optimal performance.



Lithium iron phosphate (LiFePO₄) battery

Advantages

95% depth of discharge (DoD)
More than 5000 life cycles
Higher energy density
More efficient than Lead-Acid batteries
Do not require maintenance
Eco-friendly solar batteries

Disadvantages

Comparatively more expensive

2.5.3 Factors contribute to the performance of solar battery.

Battery Life

The lifespan of a battery is influenced by various factors, including its age, type, quality, and depth of discharge. Consulting the manufacturer's specifications provides insight into the expected lifespan. Generally, lead-acid batteries last anywhere from one to 10 years, depending on usage patterns. Meanwhile, lithium-ion batteries typically endure seven to 15 years.

Depth of Discharge (DoD)

Depth of discharge indicates the extent to which a battery's stored energy is utilized before recharging. Deeper discharges typically shorten a battery's lifespan. Batteries often specify both a cycle life estimate (indicating the number of cycles it can endure at a specific depth of discharge) and a recommended maximum depth of discharge.

While both lead-acid and lithium-ion batteries deteriorate more rapidly with deep discharges, lead-acid batteries generally exhibit lower tolerance for such discharges. Regular deep discharging significantly reduces the life expectancy of lead-acid batteries compared to lithium-ion batteries.



Battery capacity

The storage capacity of a battery, measured in Ampere-hours (Ah), signifies the amount of energy it can store.

1A delivered in 1 hour = 1Ah

Multiplying this capacity by the battery voltage, we get an amount of energy in watt-hours (Wh).

Example:

12V/100Ah battery capacity $100\text{Ah} \times 12\text{V} = 1200\text{ Wh}$ or 1.2 kWh

The capacity of batteries is indicated in Ah for a certain voltage.

Example:

100Ah at 12V. This is usually for 20 hours.

A 100Ah battery will supply 5A for 20 hours

The capacity rating serves as a standardized measure to compare different batteries, but it doesn't directly determine how long a battery will last.

Batteries are electrochemical devices affected by various factors such as climate, charge/discharge cycles, temperature, and age. The performance of a battery relies on these variables, including the climate, location, and usage conditions.

Typically, for every 1Ah drawn from the battery, about 1.25Ah needs to be recharged to restore the battery's charge level to its previous state. However, this figure can vary based on factors like temperature, battery type, and its aging characteristics.

2.5.3.1 Factors on which capacity depends - Battery charge/discharge cycle

The factor on which the capacity depends are:

Battery charge/discharge cycle; Effect of temperature; State of charge and degree/depth of discharge; Self-discharge; Efficiency; C-rated

Battery charge/discharge cycle

The charge/discharge cycle of a battery results in a gradual reduction of its capacity, which is a crucial factor as excessive discharge can cause permanent damage.



Consequently, battery life is linked to the number of charge/discharge cycles and the rate of discharge.

The number of cycles significantly varies based on the battery type (Open Lead, AGM, GEL, OPzS, OPzV, Lithium).

Depth of Discharge tolerance and discharge cycles

Depth Of Discharge (DOD) pertains to how deeply the battery is drained in each cycle. Deeper discharges lead to a reduction in the number of discharge cycles and, consequently, a shorter battery service life. Lithium batteries can be discharged up to 95%, whereas lead batteries are limited to 50%. The graph below illustrates the relationship between the depth of discharge and the number of cycles for both lead and lithium batteries.

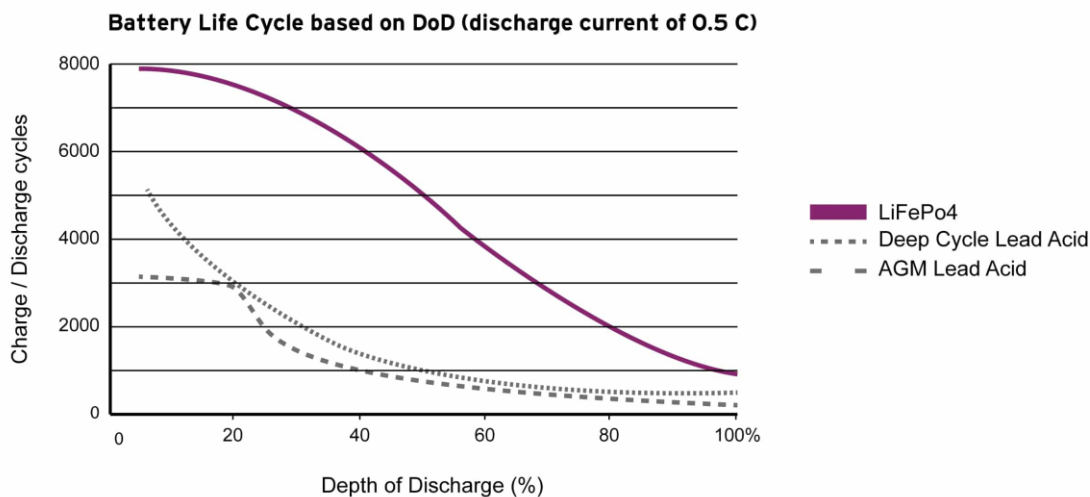

Figure: The number of charge/discharge cycles as a function of the depth of discharge source: <https://flexsolutions.com/soluxio/>

To achieve approximately 2000 cycles (equivalent to $2000/365$ days = 5.5 years), lead batteries should only be discharged between 25-35%, while for lithium batteries, it's around 80%. This means you'd need at least four times the capacity of a lithium battery to attain the same lifespan for a lead battery! In other words, if you utilize 80% of a battery's capacity, a lead battery would last for only 250-500 cycles compared to 2000 cycles for a lithium battery. A lead battery would require replacement 4-8 times more frequently than a lithium battery!

Turnaround cycle efficiency



The turnaround cycle efficiency denotes how effective the battery is during a complete charge and discharge cycle. Typically, for lead batteries, this hovers around 75%. This implies that if you charge a lead battery with 1000Wh, you'll only retrieve 750Wh for actual device power. Therefore, there's a 25% loss in system efficiency in batteries alone! For solar streetlights or similar solar-powered systems, this necessitates about 25% more solar panels to power the same load. Under such conditions, the system inevitably becomes more expensive (or performs worse for an equivalent configuration). In contrast, lithium batteries showcase a turnaround cycle efficiency of roughly 98%. Hence, the upsurge in the adoption of this battery technology comes as no surprise.

2.5.3.1 Factors on which capacity depends - Battery charge/discharge cycle

Factors on which capacity depends

Battery charge/discharge cycle

Batteries are rated both by the energy they can provide and by their cycles. They are divided into shallow and deep:

- ✓ shallow - number of discharges up to 85-90% of capacity (Ah);
- ✓ deep - number of discharges up to 30-50% of capacity (Ah).

Shallow discharge cycle batteries, such as those found in cars, are designed to deliver hundreds of amps for a few seconds. They are called starters. They start the engine, the alternator kicks in and recharges the battery very quickly.

Deep cycle batteries on the other hand deliver several amps for hundreds of hours between charges. These two types of batteries have completely different applications and should not be interchanged. Deep cycle batteries are designed to withstand multiple deep discharges and are the most suitable batteries for PV systems.

The differences between lithium and lead batteries mean for the performance and durability of a solar light pole.

	Lead	Lithium
High temperature tolerance	20oC	45oC
Low temperature tolerance	>0oC	<0oC



Turnaround cycle efficiency	75%	98%
Charge rate	0.2C	>5C
DOD tolerance	50%	95%
Discharge cycles @ 80% DOD	400-500	2000
Discharge cycles @ 30% DOD	1500	7000
Weight (vs Lead)	100%	±25%
Replacement timeframe	1.5-3 years	8-10 years
Complexity	Easy	Complicated
Environmental impact	Higher	Lower
Total cost of ownership	Higher	Lower

2.5.3.1 Factors on which capacity depends - High temperature resistance

Factors on which capacity depends

High temperature resistance

Batteries are adversely affected by high temperatures, leading to reduced service life. However, elevated temperatures impact lead-acid batteries far more than lithium batteries. Temperatures above 20°C significantly diminish the lifespan of lead-acid batteries, while lithium batteries can endure temperatures up to 45°C. For instance, when the temperature elevates from 20°C to 30°C, the service life of lead-acid batteries (e.g., AGM/GEL)* is halved. *(AGM (Absorbent Glass Mat) batteries utilize lead-acid chemistry, where the electrolyte is absorbed in a fiberglass mat, whereas GEL (Gelled Electrolyte) batteries employ a similar lead-acid chemistry but with the electrolyte in a gel-like form. AGM and GEL batteries have different charging requirements.) The following graphs clearly depict this, illustrating capacity retention against the number of charge cycles at both 20°C and 33°C. In regions like the Middle East, solar street lighting powered by lead-acid batteries will likely require replacement within 2 years (or 750 cycles). At temperatures rising from 20°C to 40°C, the service life of lead-acid batteries plummets by a significant factor of 4. Conversely,

Cycle life comparison in hot climate (33 °C)

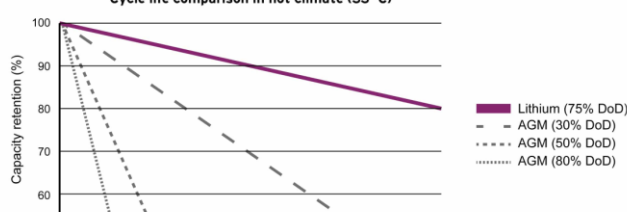

Cycle life comparison in moderate climate (20 °C)

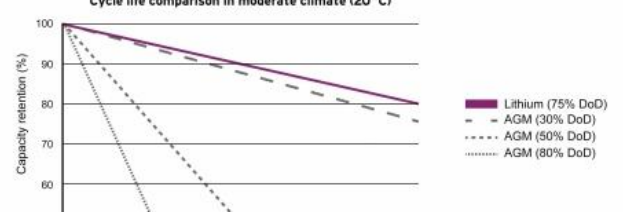

lithium-based battery technologies remain unaffected by temperatures of 40°C. Given that solar street lighting is prevalent in warm, sunny areas (where ambient temperatures often exceed 20°C), employing lithium batteries is highly recommended. Both lithium and lead batteries experience diminished energy capacity in cold weather.

Figure: Graph of the capacity variation function of the number of charge cycles for 20°C and 33°C.

Low temperature resistance

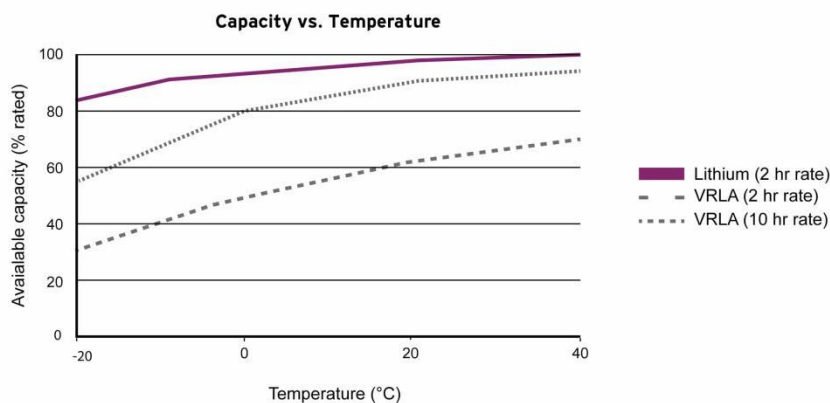

Figure: Function of Capacitance Variation with Temperature



However, lead batteries are more severely affected. At temperatures of -20°C , the useful energy capacity of lead-acid batteries decreases to 30%, as depicted in the graph below. In similar discharge conditions, lithium batteries retain 82% of their energy capacity. Consequently, lithium batteries not only endure longer in regions with high temperatures but also in areas with extremely cold conditions, such as mountainous regions

2.5.3.1. Factors on which capacity depends - C-rated

The charge and discharge rates of a battery are described by C-rates. Battery capacity is often rated at 1C, indicating that a fully charged battery with a 1Ah rating should supply 1A for one hour. In the same way, when discharging at 0.5C, it provides 500mA for two hours, and at 2C, it delivers 2A for 30 minutes. Rapid discharges lead to losses that reduce the discharge time, which also affects charge times.

A C-rate of 1C is also referred to as a one-hour discharge; 0.5C or C/2 signifies a two-hour discharge, while 0.2C or C/5 means a 5-hour discharge. Certain high-performance batteries can be charged and discharged above 1C with moderate stress.

Table illustrates typical times at various C-rates.

C-rate	Time
5C	12 min
2C	30 min
1C	1h
0.5C or C/2	2h
0.2C or C/5	5h
0.1C or C/10	10h
0.05C or C/20	20h

Battery capacity, representing the amount of energy a battery can store, can be measured using a battery analyzer. (Refer to BU-909: Battery Test Equipment.) The analyzer discharges the battery at a calibrated current while recording the time until it reaches the end-of-discharge voltage. Typically, the end-of-discharge voltage is 1.75V/cell for lead acid, 1.0V/cell for NiCd/NiMH, and 3.0V/cell for Li-ion batteries. If a 1Ah battery supplies 1A for

one hour, an analyzer displaying results as a percentage of the nominal rating will show 100 percent. If the discharge lasts only 30 minutes before hitting the end-of-discharge cut-off voltage, the battery has a capacity of 50 percent. Some new batteries are occasionally overrated and can surpass 100 percent capacity, while others are underrated and may never reach 100 percent, even after priming.

2.5.4 Battery Connection Diagram in Series and Parallel

There are mainly three types of connections are used for the battery with the aim of requirement of capacity. Those three connections are - 1. Series Connection 2. Parallel Connection 3. Series and Parallel Combination. This knowledge helps a lot to understand the capacity of a whole battery bank, or when you going to make a battery bank for UPS or Inverter system.

2.5.4.1 Battery Connection in Series

When we need more voltage than the voltage of one battery, we have to connect several batteries in series. In the figure below you can see three batteries connected in series.

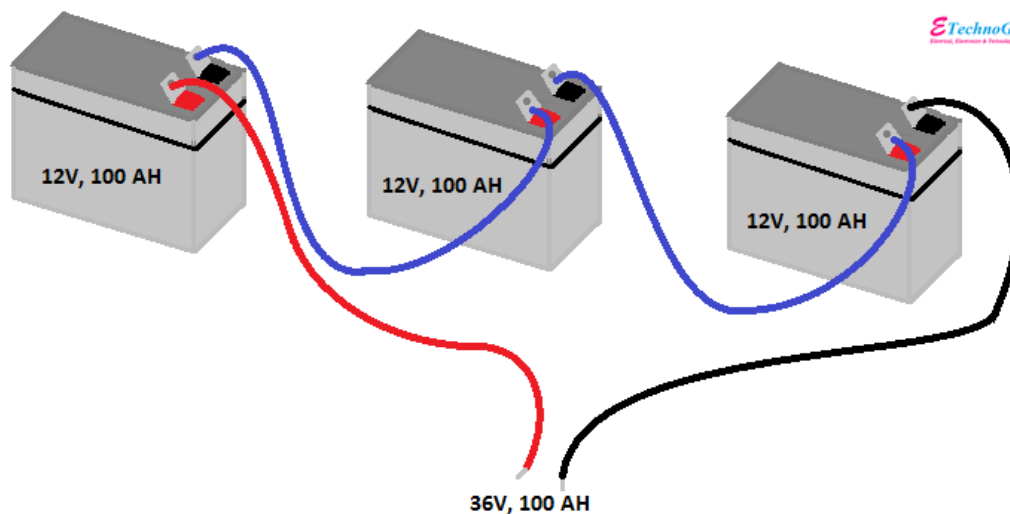

Battery Connection in Series

source: <https://www.etechnog.com/2021/05/battery-connection-diagram.html>

In the series connection of the batteries, the total voltage will increase while the current capacity remains the same. Here, you can see in the above figure, three 12V, 100AH batteries are connected in series. So the total capacity of the output will be 36V, 100AH. Remember that while connecting batteries in series, all batteries should be in the same category and in good condition. If one of them is damaged or not able to provide the rated voltage, then the output voltage of the circuit also be affected.

2.5.4.2 Battery Connection in Parallel

When we required the high ampere-hour capacity, then we need to connect batteries in parallel. Here you can see in the below figure, three batteries are connected in parallel.

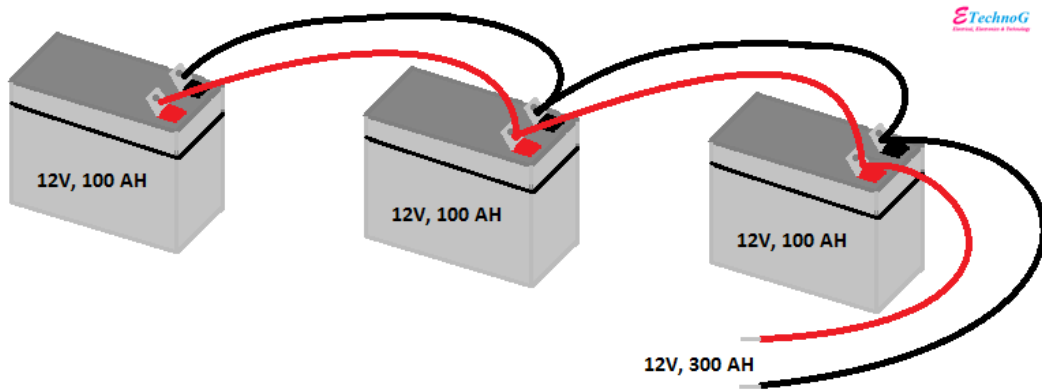

Battery Connection in Parallel

source: <https://www.etechnog.com/2021/05/battery-connection-diagram.html>

Here, you can see three 12V, 100AH batteries are connected in parallel. So the capacity of the output of the circuit will be 12V, 300AH. Here also all batteries should be in good condition. In a series connection, if any one battery is damaged then the total output voltage will be affected but in the parallel connection, if any battery damaged or not able to provide full rated voltage then the output AH capacity of the circuit will be affected.

2.5.4.3 Battery Connection Diagram in Series and Parallel

Connection of Battery in Series and Parallel Combination

Multiple batteries are needed to connect in series and parallel combination when both output voltage and ampere-hour need as per our requirement.



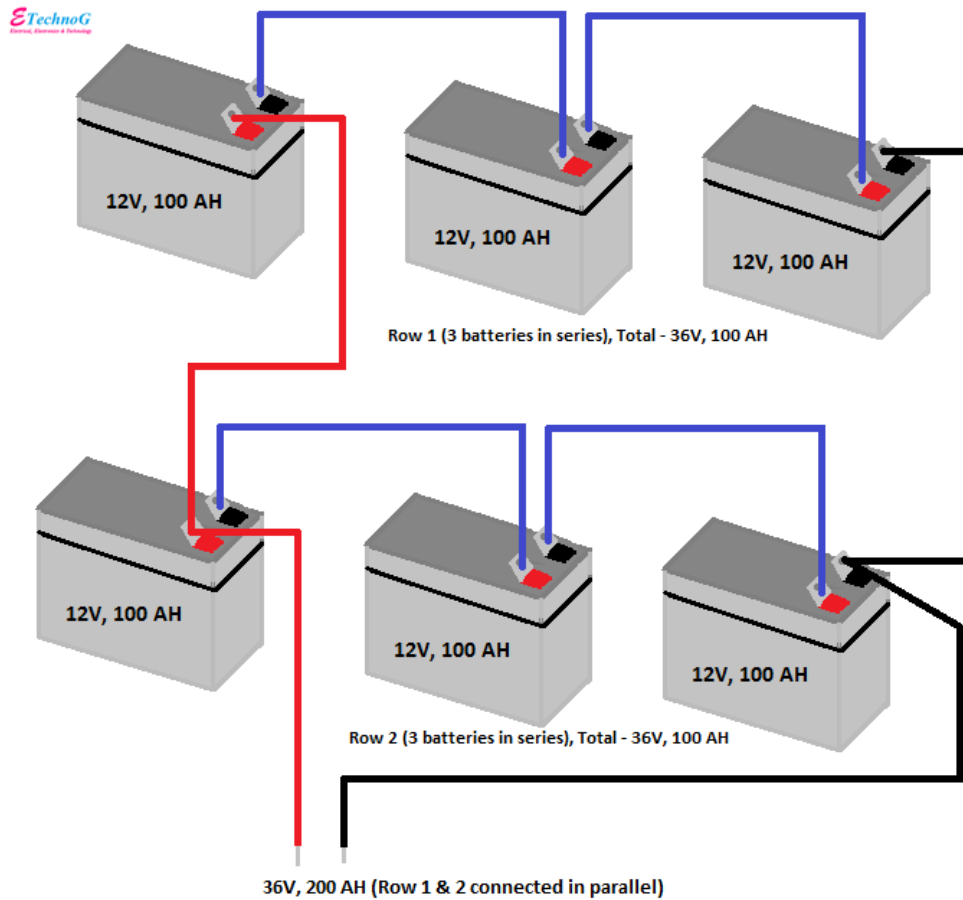

Battery Connection in Series and Parallel Combination

<https://www.etechnog.com/2021/05/battery-connection-diagram.html>

Here, you can see a total of six batteries are connected in series and parallel combination. Row 1 consists of three batteries(12V, 100AH) connected in series. So the output of Row 1 will be 36V, 100AH.

Row 2 also consists of three batteries(36V, 100AH) connected in series. So the output of Row 2 also is 36V, 100AH.

Now both rows are connected in parallel. So, the output of the total circuit will be 36V, 200AH.

2.6. The role of the DC and AC load switches. 2.6.1 Introduction.

2.6.1 Introduction.



Co-funded by
the European Union

Funded by the European Union. Views and opinions expressed are however those of the author(s) only and do not necessarily reflect those of the European Union or the European Education and Culture Executive Agency (EACEA). Neither the European Union nor EACEA can be held responsible for them.

A typical solar PV system incorporates two types of circuit breakers, each serving distinct functions and possessing different technical specifications.

The first breaker is the Array DC disconnect, designed to interrupt the DC current flow from the modules before it reaches the inverter.

The second is the AC disconnect, responsible for separating the inverter from the mains. Usually placed on the wall between the inverter and the meter, this AC breaker can either be a service panel breaker or a stand-alone switch.

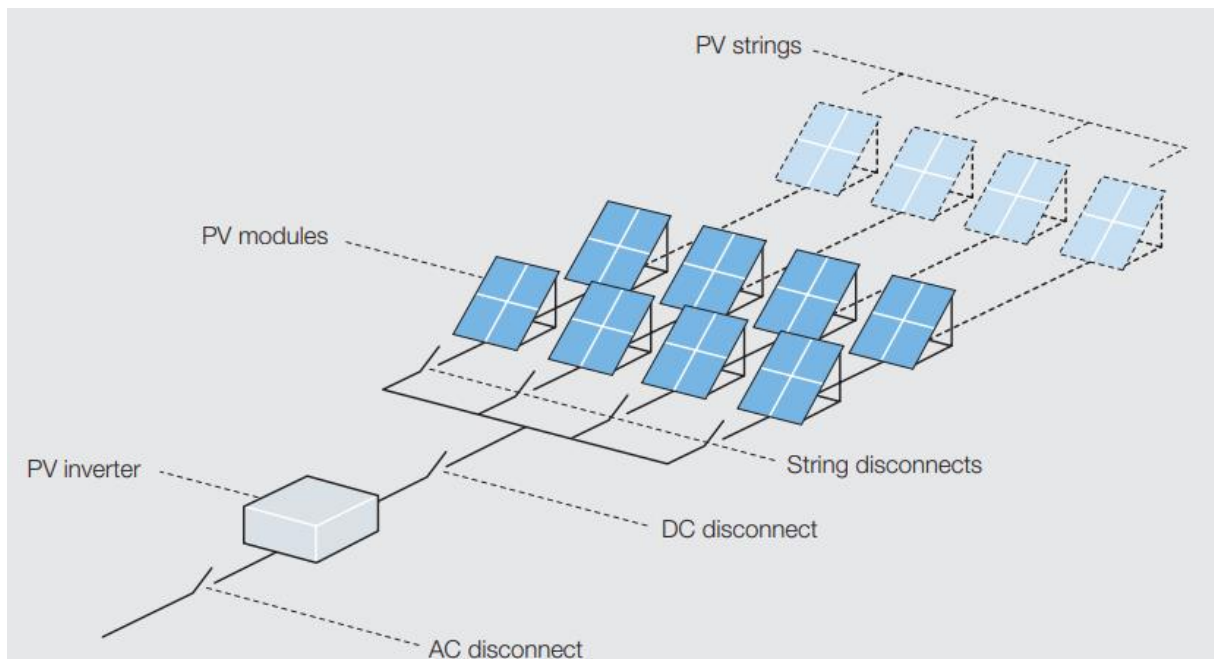

Figure: Typical design of a photovoltaic system with two types of circuit breakers (DC and AC),

source: <https://www.ee.co.za/wp-content/uploads/legacy/Vector%202012/the%20role%20of%20dc.pdf>

2.6.2 The importance of DC switch in PV system

In Germany, the Netherlands, etc. European countries, it is recommended that inverter manufacturers configure a standard built-in DC switch for each inverter.

This allows disconnection and reliable isolation of inverter from all DC sources.



Additional switching equipment can be used to switch off parts of the photovoltaic matrix, to ground the system or to switch possible energy storage circuits.

DC switch is an important protection device in the application of photovoltaic system, which directly affects the safe and reliable operation of the photovoltaic system. Thus affecting the stability of the entire photovoltaic power generation and revenue, especially in the DC 1500V photovoltaic system. To ensure the safe, stable and reliable operation of photovoltaic systems, as well as safety maintenance system operation and maintenance installation and commissioning process, selecting a suitable DC switch is of vital importance.



Figure: A DC switch source: <https://www.chinasuntree.com/suntree-news/the-importance-of-dc-switch-in-pv-system-application.htm>

Presently, the so-called PV DC switches available in the domestic market are primarily AC switches or their modified versions, lacking the safety interrupter and high power cut-off functionality required in a photovoltaic system. These AC switches possess notably low arc capacities and insufficient rated load cut-off power, leading to potential overheating, leaks, sparks, and severe risks such as fires in the entire photovoltaic power plant. Thus, selecting a qualified PV DC switch becomes a critical necessity.

2.6.2. The importance of DC switch in PV system

The importance of DC switch in PV system

The selection of qualified PV DC switches is critical.



Here are some steps to choose a DC switch:

First step sizing the system voltage

The rated operating voltage of the circuit switch must be equal to or greater than the system requirements. It is common to meet UL508i 600V, IEC60947-3 1000V and 1500V. Typically, the system voltage connected to single-phase inverters is up to 600V, three-phase string inverters or centralized inverters up to 1000V or 1500V.

Second step - number of strings to be isolated

2 Pole - Single string, 4 Pole - Two string, etc.

For built-in DC Isolators, the number of MPPT's of the inverter determines the poles of a DC Isolator. Common string inverters are with a single MPPT, dual MPPT's and a few, triple MPPT's. Generally speaking, an inverter, power rating at 1kW ~ 3kW, is designed with single MPPT; 3kW ~ 30kW with dual MPPT's or few triple.

For external DC Isolators, you can choose 4 Pole, 6 Pole, 8 Pole for multi-string solar panels or select 2 Pole for one string of solar panel, based on the different system design (see Figure)

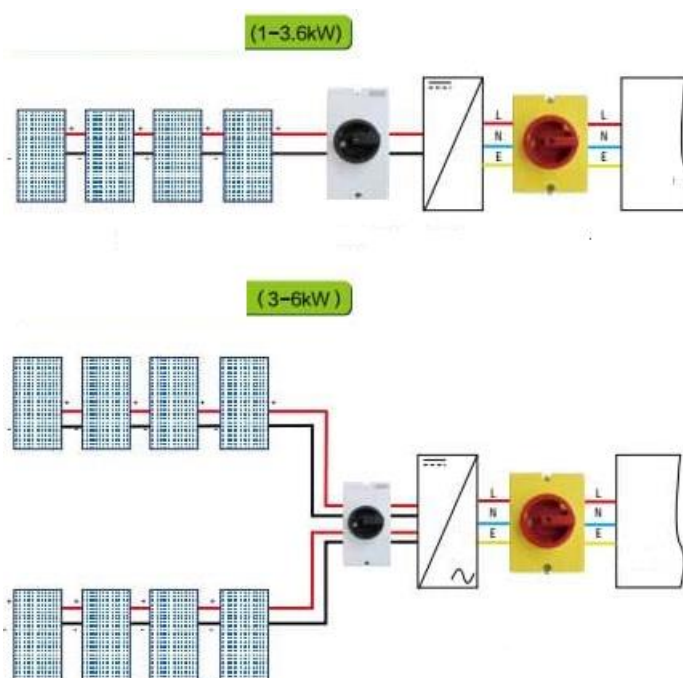

Figure: Single-string and multi-string DC circuit breakers, source: <https://www.projoy-electric.com/A-Principle-of-Selecting-DC-Isolators-for-PV-Systems>

2.6.2 The importance of DC switch in PV system -Sizing Example

The importance of DC switch in PV system

Sizing Example - Disconnect Switches Applications in Photovoltaic Systems

Assume that a disconnect switch must be chosen to provide means for disconnecting an inverter from its source. The supplying solar PV array consists of 20 parallel-connected **PV**-strings. Each string consists of 30 series-connected **PV**-modules, each of them having a maximum V_{oc} of 28.4 V_{DC} and an I_{sc} rating of 7.92 A. The highest inverter power output is obtained at the maximum power point, which occurs with approximately.

146 A (IMPP) at the inverter input.

The V_{oc} determines the minimum voltage rating of the disconnect switch:

$$30 \times 28.4 \text{ V} = 852 \text{ V.}$$

Selecting a disconnect switch with a V_i and V_e of 1000 V DC would give a safety margin greater than 15%.

The sum of ISC parallel-connected strings determines the current-capability requirements for the switch. The sum of ISC gives:

$$20 \times 7.92 \text{ A} = 158.4 \text{ A.}$$

At a minimum, NEC 690.8 requires this value to increase by **125% (or $158.4 \times 1.25 = 198\text{A}$)** to address increased currents during solar noon.

If the ambient temperature at the installation site may rise, e.g., up to 60 °C, a temperature-derating factor must be taken into account. For 60 °C the factor is 0.80. Applying the factor by dividing the maximum power-point current by the factor tells us how the disconnect switch should be rated under normal conditions: **$146 \text{ A} / 0.80 = 182.5 \text{ A}$** . The calculations have now given us a picture of the requirements for the disconnect switch and can be used to properly select a disconnect switch for a given PV application.

Environment and Installation

The working environment temperature, protection level and fire protection level should be determined according to the environment. Generally a good PV DC isolator switch can be used safely at an ambient temperature of -40°C to 60°C. Generally, the protection level of the external DC isolating switch should reach IP65; the built-in DC isolator switch should ensure



that the equipment reaches IP65. The fire rating of the housing box or main body shall comply with UL 94V-0, and the handle shall comply with UL 94V-2.

2.6.3 Miniature circuit breakers



Figure: A miniature circuit breaker, source: <https://www.eaton.com/>

Miniature circuit breakers - internationally known as MCB (miniature circuit breaker) they automatically disconnect the system from the mains if an overload or short circuit occurs.

Protects cables and electrical installation from damage caused by excessive heating as a result of excessively high current. Miniature circuit breakers can be turned on again after tripping if the fault has been rectified. In the case of direct power supply, the circuit breaker is designed according to the cable cross-section of the power cable and the information provided by the inverter manufacturer. They are also often used as AC circuit breakers.

An MCB is a better alternative to a **Fuse** since it does not require replacement once an overload is detected. Unlike a fuse, an MCB can be easily operated and thus offers improved operational safety and greater convenience without incurring a large operating cost.

A Miniature Circuit Breaker is a switchgear which is usually available in the range of 0.5A to 100A. Its Short circuit rating is given in Kiloamps (kA), and this indicates the level of its ability to work.



2.6.4 Residual Current Device (RCD)



Figure: A residual current circuit breaker, source: <https://www.ledcontrols.co.uk>

The residual current circuit breaker - also known as FI switch, internationally called **RCD** (residual current protection device) - serves to interrupt the currents of in the event of insulation failure, earthing or closing of the circuit through the body. The residual current circuit breaker monitors the current flowing in the outgoing and return conductors of the circuit. If the difference between the two currents exceeds 30 mA, the FI switch breaks the circuit within 0.2 seconds. The switches used must comply with VDE 0664-100.

If you have fixed **RCD** protection, it will reduce the risk of electric shock to you and the people who use your equipment.

2.7 Monitoring and control of PV installations. 2.7.1. Introduction

2.7.1 Monitoring and Control – Introduction

The integration of renewable energy sources and storage in buildings requires improved control and monitoring systems. These systems not only ensure optimal performance, but also aim to accelerate return on investment. Various environmental factors such as pollution, temperature and radiation can affect photovoltaic performance. Therefore, the implementation of an effective real-time monitoring system for a solar PV system can greatly



improve the accuracy and overall performance of the system.

Understanding the performance of your PV system is essential to understanding energy production, identifying problems early and taking appropriate action. The figure below illustrates the operation of a photovoltaic system.

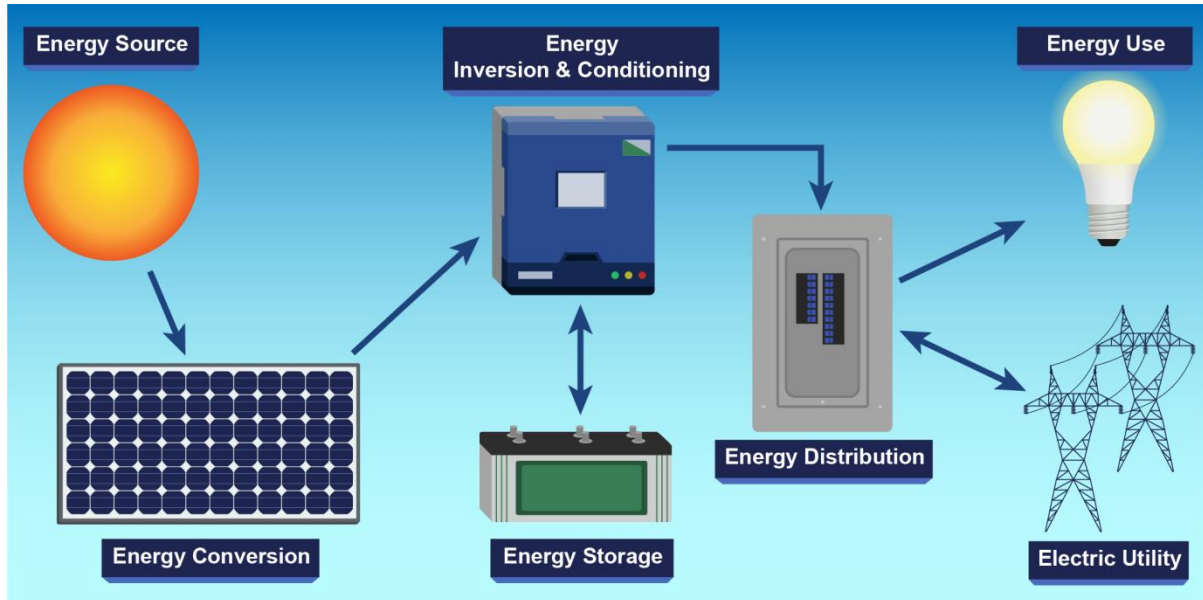

Figure: Basic diagram of a photovoltaic system and the connection of individual components. source:

<https://energyresearch.ucf.edu/>

Photovoltaic systems differ from conventional electromechanical generation systems mainly because of the equipment used. Nevertheless, the principles of operation and integration with other electrical systems are in accordance with established electrical codes and standards.

While a photovoltaic array generates energy when exposed to sunlight, several components are required to properly manage, control, convert, distribute, and store the energy produced. These components may include essential items such as a DC-AC power inverter, battery, system and battery controllers, auxiliary power sources, and sometimes certain electrical loads (appliances). In addition, a variety of balance of system (BOS) hardware may be required, including wiring, overcurrent, surge protection, tripping devices, and other power handling equipment.

Batteries play a vital role in PV systems by storing the energy generated by the PV arrays during the day and delivering it to electrical loads as needed, especially at night or during periods of cloudy weather. In addition, the batteries help operate the PV array near the maximum power point, providing stable voltages to electrical loads and supplying inrush

currents to electrical loads and inverters. In most cases, a battery charge controller is used to protect the battery from overcharging and overdischarging.

2.7.2. Monitoring and control of PV installations - Electric Meters

Meters are often underestimated components of a solar system, yet they serve as a crucial link to understanding your solar investment. They provide essential information such as the amount of electricity your system generates, your energy consumption, and the energy you still purchase from the utility company.

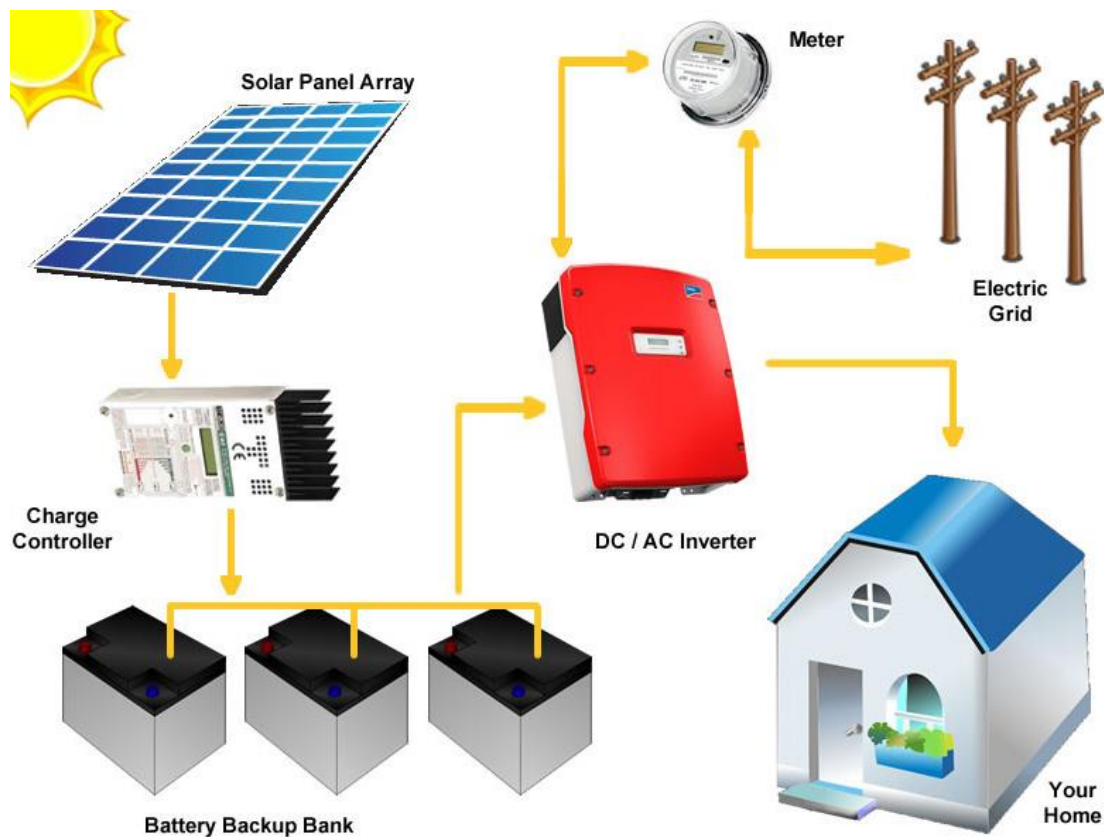

Figure: A Electric Meters, source:<https://www.ledwatcher.com>

Traditionally, utility meters were unidirectional, measuring electricity consumption flowing from your property to the power company. However, with the installation of solar systems, the needs for metering expand beyond the capability of a traditional one-way meter. Many solar systems employ net meters or smart meters that operate bidirectionally, accurately accounting for your net energy usage, calculated as the energy consumed minus the energy generated by your solar system.

Most solar systems remain interconnected with the utility grid, known as grid-tied systems, combining the cost-saving and energy independence benefits of off-grid solar power with the readily available electricity from the grid.

While a grid-tied solar system can offset 100% of your usage, it's essential to note that solar systems produce electricity only when the sun is shining. Hence, an efficient system is designed to generate surplus electricity during sunny periods.

The challenge arises when you need electricity when your solar system isn't producing. Two primary options address this issue: battery storage or utilizing the utility grid.

Batteries find common usage in small-scale residential applications, although their cost remains a limitation for many homeowners, despite ongoing technological advancements and price improvements.

Alternatively, the utility grid presents a more popular and economical solution. Through a program like net metering, available in many EU countries, surplus electricity can be stored on the grid, earning you credits from the utility company. Subsequently, during periods when your system isn't producing, you can draw electricity from the grid using these credits.

2.7.3 Monitoring and control of PV installations -Bi-directional utility meter (Smart meter)

Every owner of a grid-tied solar system requires a bi-directional utility meter to accurately track the electricity transferred to and from the grid. These meters not only measure the electricity drawn from the utility grid but also quantify the electricity sent back to the grid from your solar system.

This net usage is a measure of how much electricity you contributed to the grid relative to how much you utilized from it, resulting in either a surplus of credits or charges on your utility bill.





Figure: A smart meter, source: https://www.smartestenergy.com/en_gb/business/smart-meters/

PV Meters Connected to the Internet

Several PV meters need internet connectivity, greatly facilitating the monitoring of your solar system's production. Rather than physically checking the meter outside, you can easily access its readings through your computer or smart device. Major inverter manufacturers like SolarEdge, SMA, and Enphase collaborate with metering companies, integrating this data into the system's dashboard or online portal for convenient monitoring.

Internet-connected PV meters also enable remote monitoring by installers, aiding in maintaining system performance and fulfilling their performance guarantees.

Accessing the Vital Information for Your Solar Investment

Though often overlooked, meters play a crucial role in comprehending and monitoring your solar investment. They serve not only as vital components for net metering and performance guarantees but also provide peace of mind by offering insights into your solar system's functionality and your overall electricity usage.

2.7.4. Monitoring and control of PV installations - The digital architecture of monitoring, control and optimization functions

Monitoring and control

To comprehend the utilization of electrical energy and optimize its use, the owner of a PV system must:



Track the consumption, storage, or injection of produced photovoltaic (PV) energy into the grid.

Monitor and analyze PV production trends in conjunction with load consumption.

Calculate the economic benefits associated with reduced grid energy consumption.

A comprehensive PV monitoring system should encompass asset management functions. This includes evaluating PV system performance, detecting deviations or malfunctions, and promptly reporting any issues.

As PV inverters can influence the power quality of the electrical installation, it's advisable to measure and monitor power quality disturbances, particularly harmonics and unbalance.

2.7.4 The digital architecture of monitoring, control and optimization functions

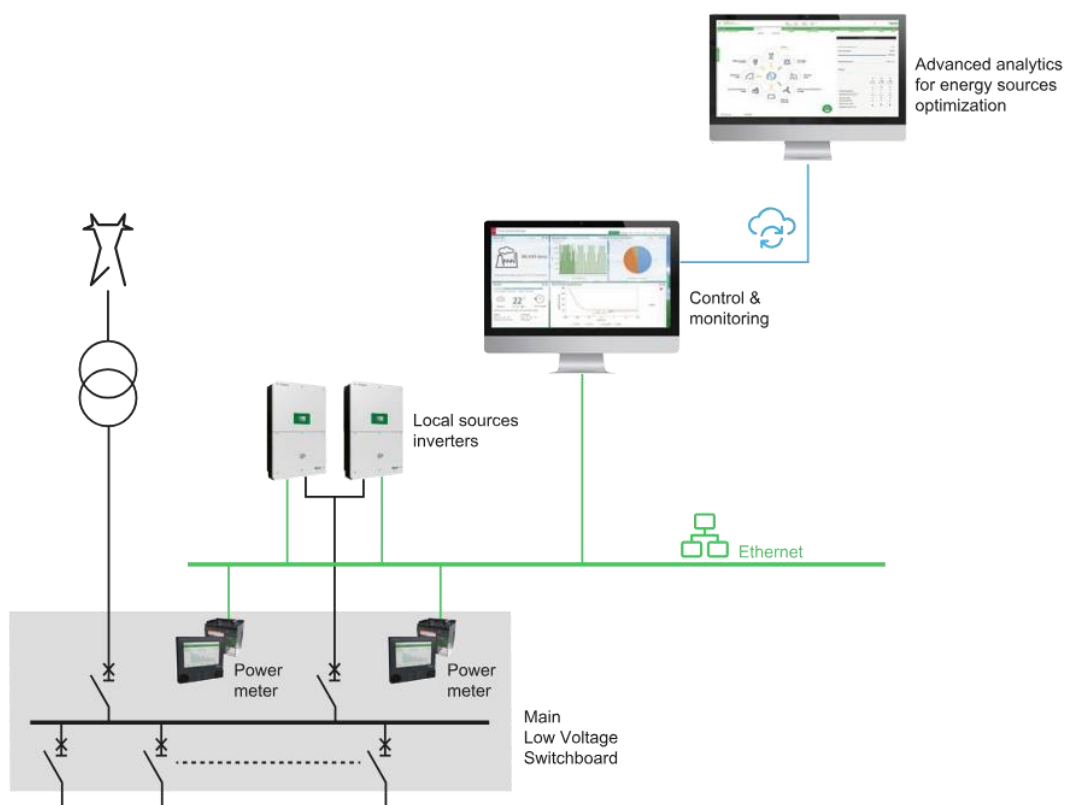

Figure: Example of digital architecture source: <https://www.electrical-installation.org/enwiki>

The initial step involves gathering input data such as:

- ✓ Photovoltaic production and inverter status from the PV inverters.
- ✓ Power measurements, energy usage, and power quality data from the power meters.
- ✓ Information on weather conditions, including temperature and irradiance, provided by sensors.

These data are collected using communication networks. High-end power measurement devices and PV inverters are typically directly connected via Ethernet. Gateways may be required for sensors and other devices.

For monitoring purposes, the data acquisition frequency can average every 10 minutes. However, when local control functions are necessary, more frequent data collection becomes essential.

The collected data are utilized by an on-premises control system to efficiently operate the electrical installation equipment. Algorithms and analytics can determine optimal set points for local energy sources and controllable loads.

Moreover, the collected data are employed by on-premises or cloud-based software for visualization, analysis, and reporting purposes.

2.7.5.-6. Monitoring and control of PV installations - Inverter Monitoring, - Weather monitoring

2.7.5 Inverter Monitoring

Remote monitoring of a solar PV inverter is crucial for efficient system operation. The inverter provides essential information related to the solar PV plant, including voltage, current, and power. This data is communicated to the Remote Monitoring System (RMS) using the Modbus communication protocol. The collected information is then retrieved from the data logger/data gateway and uploaded to a web server. System operations professionals can access this data through a highly interactive user interface.

There are various parameters monitored by an inverter through RMS:

Voltage, current, power, and energy on AC and DC sides.

Frequency and power factor.

Inverter and fault status.

Runtime of the solar PV inverter.





Figure: Monitoring information from the inverter connected to a photovoltaic plant.

2.7.6 Weather monitoring

Weather conditions significantly impact the operation and lifespan of a solar PV installation. Therefore, weather monitoring is crucial to optimize overall performance and operational efficiency. Key parameters affecting energy yield and efficiency include:

- ✓ Solar Irradiance: Measures system performance compared to ideal conditions, aiding in planning maintenance activities.
- ✓ Module/Ambient Temperature: Provides insights into module efficiency changes due to temperature fluctuations.
- ✓ Wind Speed/Direction: Monitored for plant safety; strong winds may require maintenance to prevent damage to the solar PV system



Figure: a PVmet weather station source: <https://www.powerwisesystems.com>

2.7.7. Monitoring and control of PV - String monitoring

String monitoring involves monitoring all strings of solar PV panels to track individual module output and system performance. Real-time monitoring of individual string current, common bus voltage, and internal temperature ensures effective monitoring. Data on string current, voltage, and temperature are transmitted via RS-485 cable using the Modbus protocol.

Main advantages of string monitoring:

- ✓ Identifying microcracks or defects that may reduce energy production.
- ✓ Detecting Potentially Induced Degradation (PID), which can cause efficiency losses in PV panels.
- ✓ Recognizing shading issues caused by clouds or trees that may impact system performance.

String monitoring is essential to track the solar PV system and identify key issues with the solar PV panels.





Figure: Monitoring allows individual string current and common bus voltage to be monitored in real time

2.7.8 Monitoring and control of PV installations -Administrative and preventive maintenance

PV maintenance includes Administration and Preventive maintenance.

Support Administration:

Administering the PV system ensures regular monitoring and quality performance of system activities. It involves controlling and documenting necessary tasks based on monitoring results, ensuring timely and responsible maintenance. Proper administration ensures fewer errors and well-documented operational processes, allowing the maintenance team to achieve optimal PV plant performance.





Figure: The administrative and preventive maintenance is important, source: <https://trackso.in/predictive-maintenance-on-a-solar-pv-site>

Preventive maintenance:

Preventive maintenance is a consistent plan to ensure all system components function correctly and prevent technical problems from degrading the system. Solar arrays should undergo preventive maintenance inspections at least annually, adjusted based on system size. This includes comprehensive testing of physical and electrical components, focusing on panels, electrical connections, and inverters. Corrective maintenance is applied if issues arise.

Why is preventive maintenance important?

Preventive maintenance ensures maximum yield, uptime, and efficiency of solar arrays, safeguarding the investment and maintaining optimal system performance. Regular maintenance prevents potential malfunctions that could diminish the system's financial value. Investing in preventive maintenance protects the system's efficiency, overall production, and system safety.

Without routine maintenance, the likelihood of larger problems impacting production increases. Engaging in preventive maintenance is crucial to optimize system performance and return on investment (ROI).

3. Site survey and shading analysis are important elements for the proper functioning and efficiency of the PV system.

Content

- 3.1. Different types of sun shades
- 3.2. Shading serial connections
- 3.3. Shading in parallel connections
- 3.4. Possible options to reduce the effect of shading
- 3.5. Overcoming the shading problem using power electronics devices to the modules



3.1. Different types of sun shades

Solar shades and photovoltaic systems

Shading analysis stands out as one of the pivotal steps in designing or analyzing a solar energy system. In many instances, overshadowing is a prevailing concern. Hence, conducting a shading analysis during the site survey becomes imperative to evaluate potential obstacles, such as trees or buildings, that might obstruct sunlight. Equations are available to compute solar shading, offering customers a realistic expectation regarding the energy output achievable by the PV system.



Figure: A different types of solar shading, source: <https://a-sol.si/solar-edge-en/shading-of-pv-systems-the-solution/>

Different Types of Sun Shades:

Temporary Shading

Temporary shading encompasses shade occurrences resulting from clouds, bird droppings, dust, or fallen leaves.

Building-Generated Shading

Shadings arising from buildings are critical due to direct shadow creation. Examples include chimneys, lightning conductors, satellite dishes, antennae, roof and façade protrusions, offset building structures, and roof superstructures, among others.



Location-Induced Shading

Shading from the surroundings of the building is derived from factors like trees or bushes, cables traversing over buildings, neighboring or distant buildings, which may cause horizon darkening.

Self-Shading

In rack-mount systems, self-shading can occur due to the arrangement of modules. In such cases, optimizing the slope and distance between module rows becomes necessary.

Direct Shading

Direct shading can lead to significant energy losses as nearby objects casting shadows hinder solar PV panels from capturing light efficiently.

3.2. Shading in serial connections

How does solar panel shading work?

Solar panel connections in traditional setups were often arranged in parallel "strings." These interconnected panels functioned collectively, whereby the system's output was diminished to the level of the weakest panel.

In a series connection, shading affecting a single panel within the string, be it due to a tree or obstruction, impacts the output of the entire string. The shading of a single cell in a module could halve the power generation. Even with numerous cells within the string, the shaded cell would determine the output power of the entire module, effectively reducing it to zero.

Shading in Series Connections

It's crucial to note that while voltage increases when panels are connected in series, the current remains constant.

When shading affects only one panel, it diminishes the current level. In series connection, the string's current is dictated by the lowest value within it. For instance:



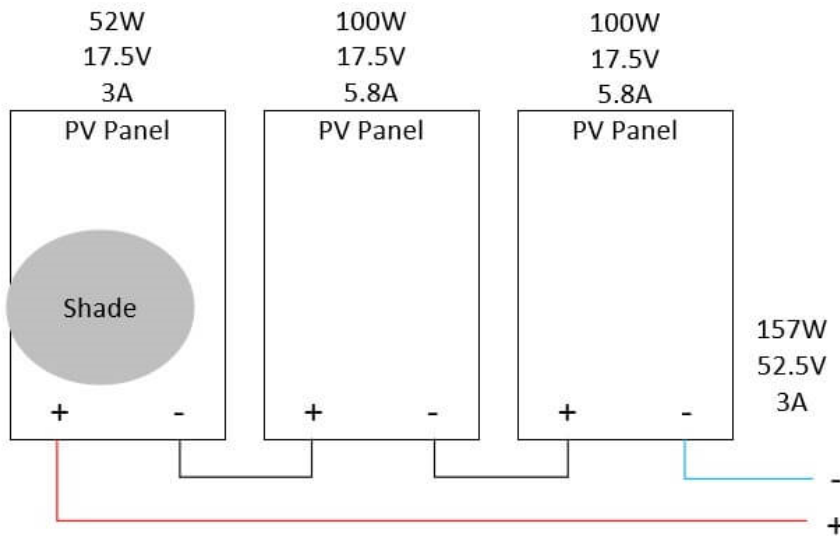

Figure: Serial connection panels, source: <https://cleversolarpower.com/shading-solar-panels/>

If shading affects one panel, reducing its output to 3 amps at 52.5 volts, the entire string of panels will produce a total power of 157 watts (52.5 volts x 3 amps), significantly less than the original 300 watts (52.5 volts x 5.8 amps).

3.3 Shading in parallel connections

How Does Solar Panel Shading Work?

Effect Of Shading In Parallel Connections

In parallel connections, conducting the same experiment yields higher power output.

This occurs because in parallel connections, the voltage remains consistent, while the current accumulates.

It's important to remember that solar irradiance (sunlight) affects only the current and not the voltage.

If we add up the currents - 3 amps + 5.8 amps + 5.8 amps - we get a total of 14.6 amps. When multiplied by a voltage of 17.5, this results in 255 watts, surpassing the 157 watts generated in a series connection.



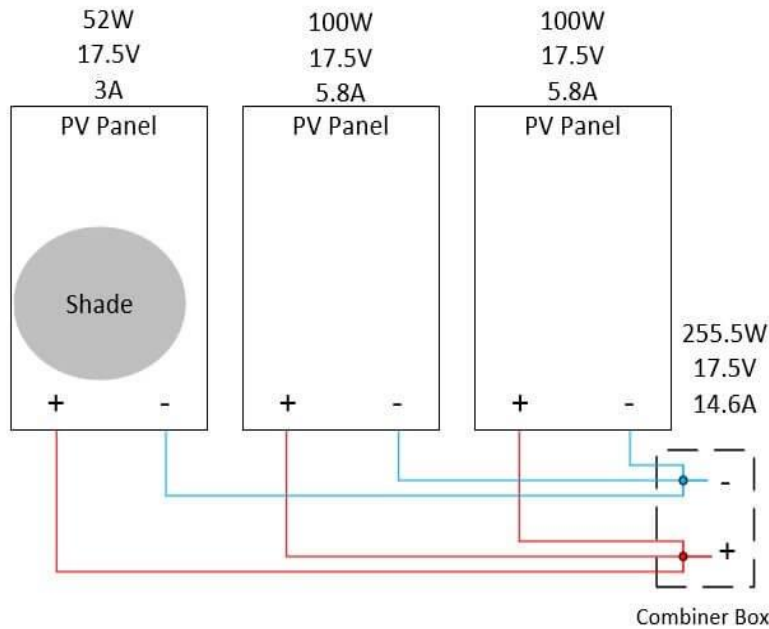

Figure: In parallel connection panels, source: <https://cleversolarpower.com/shading-solar-panels/>

3.4. Possible options to reduce the effect of shading

Possible options to reduce the effect of shading

Shading can significantly reduce the effectiveness of a solar power generation system, even if only a small portion of the array is affected. To mitigate this impact, additional design considerations are necessary.

Let's explore the potential of several options in minimizing the consequences of shading on photovoltaic panels:

Bypass Diodes: Bypass diodes are embedded within solar modules and enable electrical current to bypass shaded sections of the module. This functionality allows the unshaded cell strings to carry higher current by redirecting it around shaded areas. However, the drawback is the loss of solar output from the skipped-over PV cells. Typically, a solar module contains a limited number of bypass diodes, often grouping cells into series cell strings.

String Inverters: String inverters are commonly used in solar arrays. They convert the direct current (DC) produced by solar panels into alternating current (AC) for use in the home



or grid. However, shading on any part of a string affects the overall output, impacting the efficiency of the entire string.

Microinverters: Microinverters are installed on each individual solar panel. They convert the DC power generated by each panel directly into AC power, minimizing the effect of shading on the entire system. This means that shaded panels do not affect the performance of unshaded panels, thereby optimizing the overall power output.

Power Optimizers with String Inverters: Power optimizers work in conjunction with string inverters. They are placed on individual panels, enabling panel-level optimization while still using a string inverter. This setup allows for better performance, especially under partial shading conditions, by mitigating losses due to shading on a specific panel.

Bypass diodes, string inverters, microinverters, and power optimizers are among the solutions used to alleviate the impact of shading on solar panel systems, each offering distinct advantages and trade-offs.

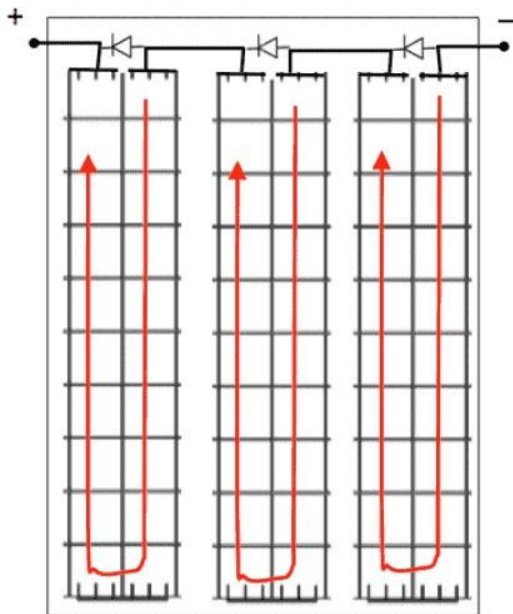

Figure: PV module containing three cell strings in series, each with a parallel bypass diode, source: <https://aurorasolar.com>

3.4. Possible options to reduce the effect of shading

Blocking Diodes and Bypass Diodes in Photovoltaic Systems



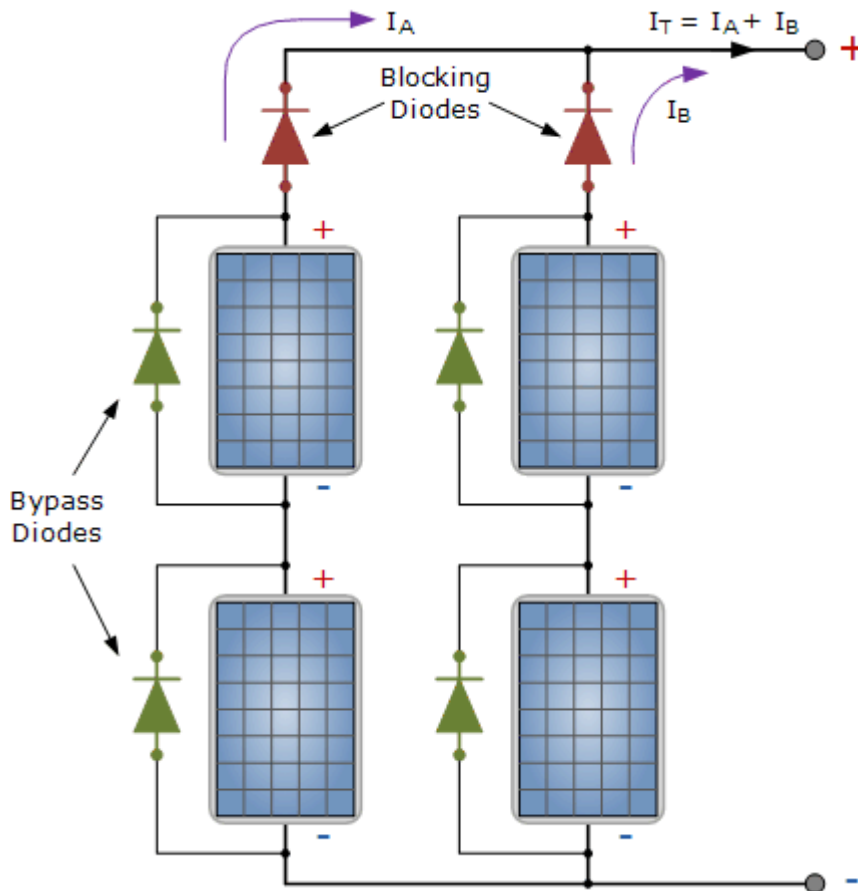

Figure: Bypass diodes and blocking diodes in **photovoltaic** arrays, source: <https://www.electronics-tutorials.ws/>

Blocking diodes

Blocking diodes are distinct from bypass diodes in their function and installation method. They are connected in series with the photovoltaic (PV) panels to prevent the current from flowing back into them. While the physical diode might often be the same as a bypass diode, the installation and purpose are different. In a series array, blocking diodes, typically colored red, are connected, with each diode installed in series with a series branch.

These blocking diodes, also known as series or isolation diodes, ensure that electrical current flows only in one direction—out of the series array to external loads, controllers, or batteries. This directionality prevents current from parallel-connected PV panels in the same array flowing back through a weaker, shaded network and also prevents fully charged batteries from discharging back through the array at night. When multiple solar panels are connected in parallel, blocking diodes should be used in each parallel-connected branch.

Bypass Diodes



Bypass diodes, marked in green, are installed in parallel with each solar panel to offer a low-resistance path. These diodes allow a safe path for current flow in the event of shading or panel malfunctions. There are two primary types of diodes used as bypass diodes in solar panels: the PN-junction silicon diode and the Schottky barrier diode. Both types come with various current ratings. The Schottky barrier diode typically has a lower forward voltage drop, around 0.4 volts compared to the silicon diode's 0.7 volts, enhancing efficiency by reducing power dissipation in the blocking diode.

Most solar panel manufacturers incorporate both blocking diodes and bypass diodes into their panels, streamlining the design process and ensuring the system's effectiveness.

3.5. Overcoming the shading problem using power electronics devices to the modules

Micro-inverters and DC optimisers how they work?

Micro-inverters and DC optimizers serve as module-level power electronics (MLPE) aimed at enhancing the performance of solar panels, particularly in situations where shading or varying conditions might hinder the overall system output.

Micro-Inverters:

A micro-inverter is a type of MLPE that performs DC to AC conversion at the module level. It functions by managing each solar panel independently, optimizing the power output of individual panels irrespective of the others in the array. When connected to a solar panel, the micro-inverter converts the DC power generated by the panel directly into AC power. By handling the DC to AC conversion at the module level, each panel operates independently and efficiently.

The micro-inverter continuously tracks the maximum power point of each module, even when panels are connected in parallel. This allows for better performance, especially in scenarios where shading or other factors might affect the output of specific panels. Unlike conventional solar installations with string inverters, micro-inverters ensure each panel operates optimally on its own.

DC Optimizers:

Similar to micro-inverters, DC optimizers are another type of MLPE designed to improve the performance of solar panels. They work by performing Maximum Power Point Tracking (MPPT) at the module level, optimizing the DC output of individual panels before transmitting it to a central inverter for conversion to AC power. DC optimizers regulate the voltage of each panel, allowing them to perform at their maximum capacity, regardless of shading or differing conditions affecting other panels in the array.

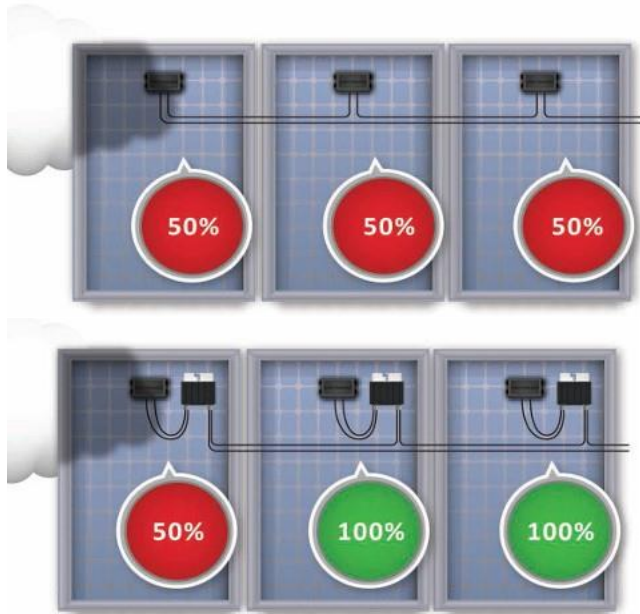

Figure: An example of overcoming the shading problem using power electronics devices to the modules, source:<https://a-sol.si/solar-edge-en/shading-of-pv-systems-the-solution/>

DC optimizers operate by adjusting the voltage of each panel to ensure that the system can overcome partial shading or other limitations, thereby maximizing the energy harvest from the entire array.

The Micro-Inverter

Both micro-inverters and DC optimizers provide enhanced efficiency by addressing issues like shading, soiling, or varying conditions that might hinder the overall output of a solar panel array. They offer flexibility and improved performance compared to traditional string inverters, particularly in scenarios with partial shading or panel mismatch.

Micro-inverters and DC optimizers function as module-level electronics integrated into solar systems to improve overall performance, particularly in scenarios involving shading or varying panel conditions.

The Micro-Inverter

In traditional solar setups, panels are connected in series to form a string, connected to a standard string inverter. Consequently, shaded panels within the string can negatively affect the performance of other modules.

Micro-inverters work differently. Instead of connecting solar panels in series, they attach directly to individual panels. This means each panel functions independently, converting DC



power from the panel to AC power. By doing so, micro-inverters maximize the output of each panel, unaffected by shading or differing conditions affecting other panels in the array.

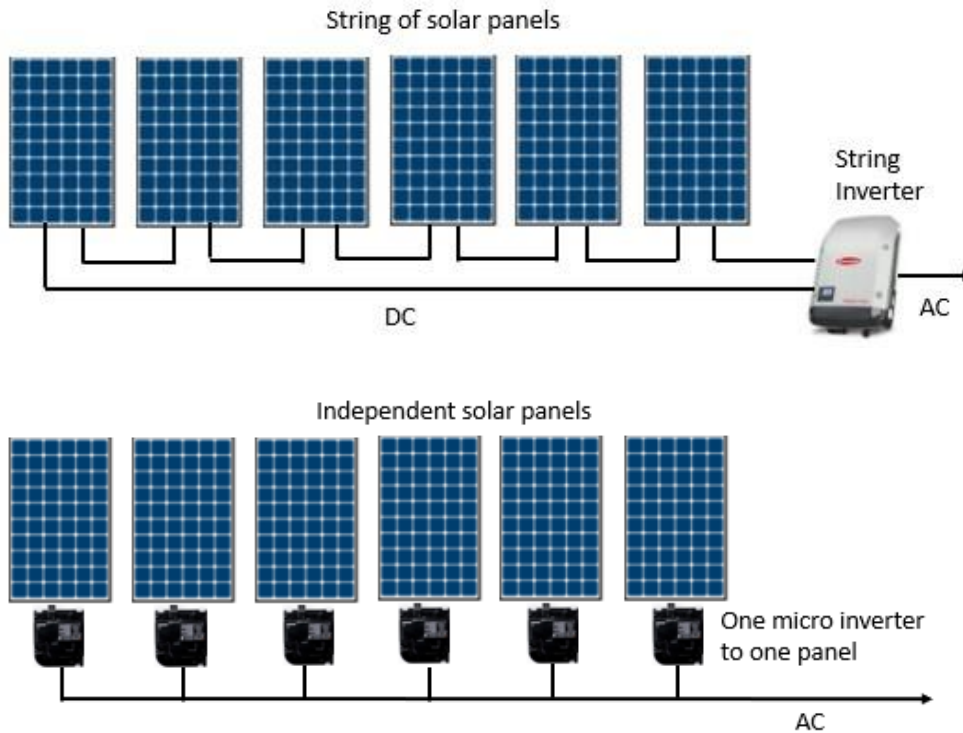

Figure: A typical solar system (string inverter) versus a micro inverter solar system, source: <https://instylesolar.com/blog/micro-inverters-vs-dc-optimisers/>

The DC Optimizer

In a conventional solar setup, DC optimizers are added to the system to enhance the DC output of each solar panel before sending it to the central string inverter for DC to AC conversion.

The DC optimizer doesn't significantly alter the typical solar power system. It's installed behind the solar panels to optimize the DC output of each panel. The optimized DC power is then transmitted to the central inverter for conversion to AC power.

Both micro-inverters and DC optimizers aim to improve the overall efficiency of solar systems by addressing issues like shading or panel mismatch, ensuring that each panel operates optimally. While micro-inverters directly convert DC to AC at the module level, DC optimizers enhance the DC output of individual panels before reaching the central inverter.

These technologies help maximize the energy harvest of solar panel arrays, especially in situations with shading or varying panel conditions.

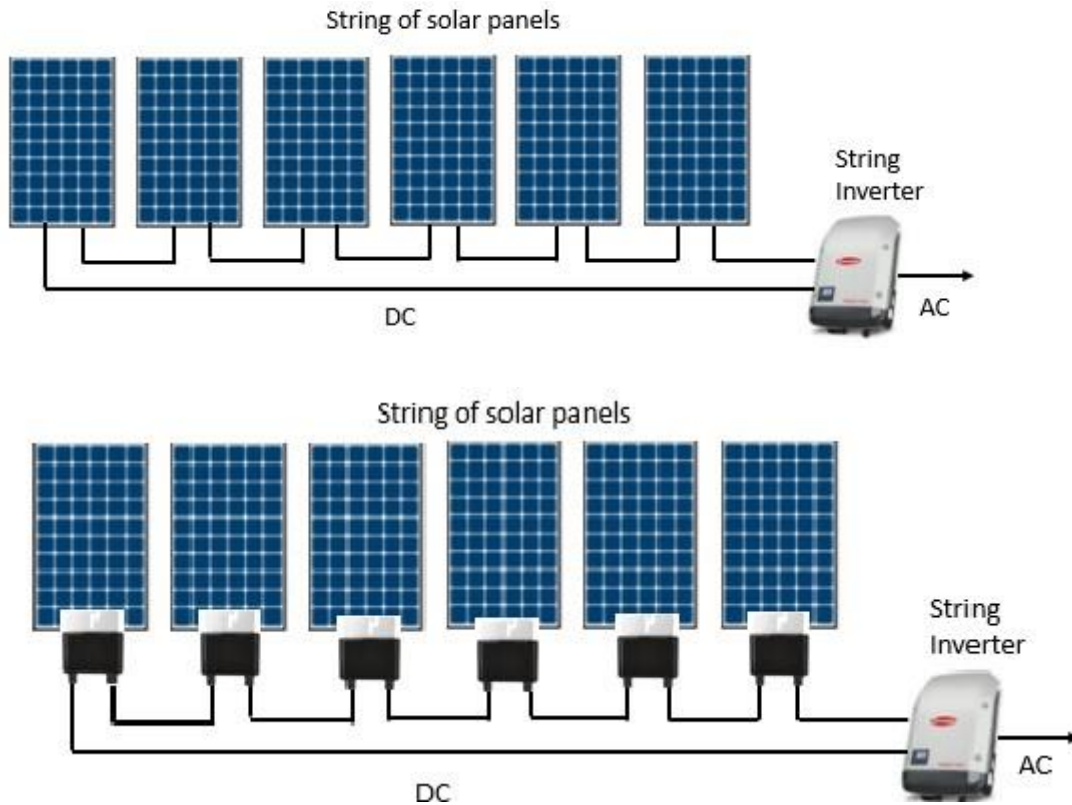

Figure: A typical solar system vs a DC optimiser solar system,
source: <https://instylesolar.com/blog/micro-inverters-vs-dc-optimisers/>

Micro-inverters and DC optimizers, known as module-level power electronics (MLPE), offer several shared advantages in enhancing solar system performance:

- Improved solar production under shading
- Reduction of panel mismatch losses
- Rapid shutdown requirement
- Improved solar energy efficiency
- Module monitoring

1. Improved Solar Production With Shading Performance

MLPE facilitates Maximum Power Point Tracking (MPPT) individually for each module, ensuring that the power output of each panel operates independently of others in the array. In scenarios involving shading (from new buildings, neighboring houses, or trees), systems with

centralized or string inverter topologies might see reduced power production as the whole string's output diminishes to the level of the weakest, shaded module. MLPE technology mitigates this issue. If an individual module is shaded in an MLPE system, it operates below its optimum level but doesn't affect the output of other unshaded modules, thereby ensuring the unshaded modules continue to work at their maximum potential. Both micro-inverters and DC optimizers excel in this function.

2. Reduction of "mismatch" losses.

Absolutely, the reduction of "mismatch" losses is a critical advantage provided by micro-inverters and DC power optimizers in solar installations. Mismatch losses occur when different modules within a solar array have varying maximum power points, typically due to differences in orientation, shading, or changes in individual module performance.

Here's a more detailed breakdown of how mismatch losses can occur and how MLPEs such as micro-inverters and DC optimizers mitigate these losses:

- **Different Orientations and Mismatch Losses:** In situations where space limitations dictate the installation of solar modules in different orientations, mismatch losses can arise. These losses result from each string of modules receiving varying levels of solar radiation throughout the day, leading to different maximum power points. With a central inverter, when performing Maximum Power Point Tracking (MPPT), it can only approximate a setting for the entire string, causing losses in power production.
- **Effect of Module Replacement on Mismatch Losses:** Additionally, in cases where a single module within the system needs replacement due to damage or other reasons, finding an exact match might be challenging as solar technology evolves, rendering certain models obsolete. Installing a module with different characteristics or specifications in a string-connected system can lead to significant power losses due to mismatched maximum power points.
- **Role of Micro-Inverters and DC Optimizers:** Micro-inverters and DC optimizers eliminate mismatch losses effectively by allowing each module's power output to operate independently of the others. With MLPE technology, every panel is optimized separately, ensuring that each module performs at its maximum power point. This independence means that modules can have varying orientations or characteristics without negatively affecting the performance of the entire system, mitigating mismatch losses entirely.

The ability to avoid mismatch losses entirely is a significant advantage of MLPEs, as it allows for flexibility in module orientation and replacement, ensuring the overall efficiency and output of the solar system are maximized regardless of individual module differences.

3. Rapid shutdown requirements



Certainly, both micro-inverters and DC optimizers play a critical role in meeting rapid shutdown requirements for PV systems, particularly when it comes to ensuring safety in the absence of mains power, whether it be locally or remotely. Here's how these devices satisfy fast shutdown requirements:

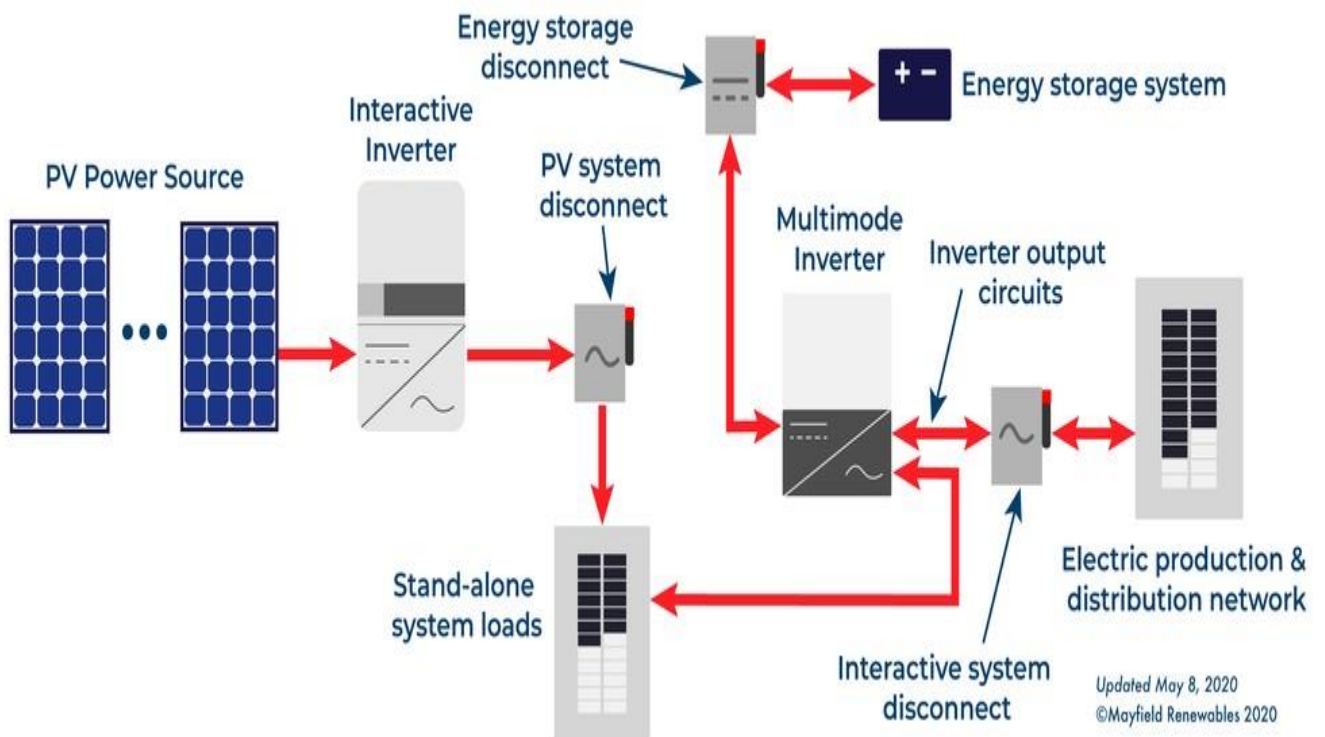

Figure: An AC-coupled multimode system with three system shutdown buttons, source:<https://www.mayfield.energy/blog/nec-2017-pv-disconnect-placement>

- ◆ **Local and Remote Rapid Shutdown Capability:** Micro-inverters and DC optimizers offer the capability for both local and remote rapid shutdown. These devices have built-in mechanisms that allow for immediate deactivation of solar modules at the module level, ensuring a quick reduction of DC voltage in the absence of mains power. They can be remotely controlled or activated locally through specific systems or devices.
- ◆ **Compliance with Rapid Shutdown Requirements:** National electrical codes, including those in Europe, mandate rapid shutdown requirements that necessitate the ability to rapidly reduce DC voltage from all system components, including solar modules, to a minimum level during emergencies or power outages. Micro-inverters and DC optimizers fulfill this requirement effectively by lowering the voltage output at the module level to comply with **safety standards**.
- ◆ **Module-Level Shutdown Performance:** Micro-inverters set the module's voltage output to zero, ensuring complete de-energization of the panel. On the other hand, DC optimizers reduce the module voltage to a safe level of around 1 volt. Both approaches effectively minimize electrical hazards, ensuring safety for firefighters, maintenance personnel, and others in unforeseen circumstances, even in the absence of mains power.
- ◆ **Safety Benefits During Unusual Conditions:** These module-level power electronics (MLPE) are designed to ensure that the system remains safe during abnormal conditions, such as power outages or emergencies. By meeting rapid shutdown requirements and swiftly deactivating module voltage, micro-inverters and DC optimizers enhance safety for personnel and first responders, even when the main power supply is unavailable.
- ◆ **System Costs and Savings:** While rapid shutdown requirements may increase the initial cost of the solar system due to the need for specific combiner boxes, incorporating micro-inverters or DC optimizers ultimately provides cost-saving benefits. The enhanced safety features they offer contribute to long-term savings by reducing potential risks, ensuring compliance, and protecting both the system and personnel from electrical hazards.

4. Solar Energy Efficiency

- **DC Optimizers Efficiency:** Manufacturers often advertise DC optimizers as highly efficient, claiming efficiencies of around 99.5%. However, these devices act as DC-DC converters. While their own efficiency may be high, they don't directly convert DC to AC. Instead, this task is performed by the central inverter, which introduces some losses. Factoring in the central inverter's efficiency, the overall weighted efficiency of a system using DC optimizers averages around 98.8%.
- **Micro-inverters Efficiency:** Micro-inverters directly convert DC to AC at the module level. Their rated efficiency typically represents the overall output power efficiency and



is usually stated around 97%. While this might be slightly lower compared to DC optimizers, it's worth noting that the efficiency loss is generally minimal, usually around 2%. This difference may vary based on brand and model.



Figure: A string Inverters /A micro Inverters and DC Optimizers,
source: <https://kubyenergy.ca/blog/stringvsmicro-inverters>

5. Module Monitoring

- ✓ **Monitoring via MLPE:** Module-level power electronics (MLPE) such as micro-inverters and DC optimizers provide a significant advantage in system monitoring. These systems allow the tracking of each module's performance, providing an estimate of expected energy output and peak power from individual panels.
- ✓ **Assessment of PV System Performance:** This monitoring capability is valuable when assessing the overall performance of the PV system against its design. It allows users to check if the system is functioning as expected.
- ✓ **Fault Detection:** MLPE enable easier detection of faults or issues within the system. By monitoring individual panels' output power, these systems allow for more precise identification of any underperforming or malfunctioning modules, aiding in quicker fault detection and troubleshooting.

In summary, both DC optimizers and micro-inverters offer high efficiency with slight differences, and both provide robust module-level monitoring, allowing users to assess system performance accurately and quickly detect and address any issues that may arise within the system.



Micro-inverters and DC Optimisers - Differences

Since microinverters and power optimizers (DC optimizers) for optimizing solar panels are very different, sometimes one may be more suitable than the other.

The differences between microinverters and DC optimisers can be seen in:

- ✓ System's expansion restriction
- ✓ Safety concerns
- ✓ Effect against PID (potential induced degradation)
- ✓ System's reliability
- ✓ Cost
- ✓ Power clipping
- ✓ Compatibility with solar batteries

1. Expanding PV System

Micro-inverters: Highly suitable for system expansion due to their independent operation. Adding more solar panels involves simply adding the corresponding number of micro-inverters. This flexibility makes scaling up the system straightforward.

DC Optimisers: Expansion can be more complex as the system's size needs to align with the maximum DC voltage input of the central or string inverter. Adding panels beyond this limit might require changing the inverter, leading to higher costs.

2. Safety concerns

Micro-inverters: Offer enhanced safety by self-extinguishing arc faults between conductors, reducing potential hazards in regular operation.

DC Optimisers: While both micro-inverters and DC optimisers shut down during grid failures or when turned off, the configuration of DC optimisers can lead to increased DC voltage, which is considered more dangerous. The modules connected in series may collectively increase voltage levels, posing a potential safety risk.

These distinctions are critical when choosing between micro-inverters and DC optimisers, especially concerning ease of system expansion and safety considerations.

Micro-inverters and DC Optimisers - Differences

3. Potential Induced Degradation (PID)

DC Optimisers: These devices conduct Maximum Power Point Tracking (MPPT) at the module level but maintain high output voltage levels for the entire system. As a result, DC

optimisers do not effectively mitigate the risks associated with PID. Since the overall system voltage remains high, the likelihood of PID-related issues is not significantly reduced.

Micro-inverters: In contrast, microinverters manage voltage and power conversion at the module level. By doing so, they maintain lower voltage levels within individual modules. This approach substantially minimizes the probability of failure due to PID within a PV system.

The distinction between how micro-inverters and DC optimisers handle PID underscores how micro-inverters' module-level operation can effectively reduce the potential risks associated with this phenomenon compared to DC optimisers.

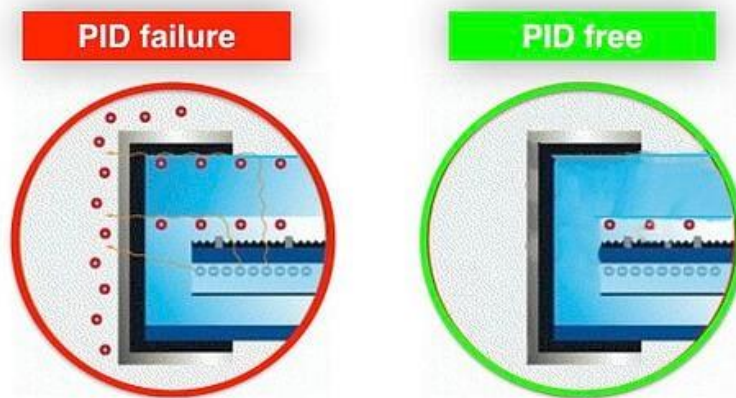

Figure: An example of the Potentially Induced Degradation effect (PID),
source: <https://www.novogenio.com/>

Micro-inverters and DC Optimisers - Differences

4. System's reliability

DC Optimisers: A notable disadvantage of DC optimisers is the potential for a single failure to impact the entire string or even the entire PV array. In a system utilizing DC optimisers, if any individual optimiser, communication system (between optimiser and inverter), or the central inverter fails, it can lead to the failure of the entire solar system.

Micro-inverters: Microinverters exhibit high reliability as their AC power output sources are decentralized. Each solar panel attached to a microinverter operates independently. If a microinverter fails, only the production from the specific panel connected to that microinverter is affected, minimizing the impact on the entire system.





Figure: Micro-inverters or DC Optimisers, source: <https://www.solarquotes.com.au/>

5. Cost

Micro-inverters: The main downside of microinverters is their higher cost compared to other PV system configurations. Because each module requires its own microinverter, the system involves additional electronic devices, leading to a relatively higher overall cost.

DC Optimisers: In comparison, DC power optimisers tend to have a lower cost per Watt. According to SolarEdge, the cost per Watt for DC power optimisers ranges from approximately 0.4 to 0.55 USD, while micro-inverters are typically priced between 0.56 and 0.66 USD per Watt.

Micro-inverters and DC Optimisers - Differences

6. Power clipping

SolarEdge DC Power Optimisers: SolarEdge DC power optimisers are designed to work with modules of up to 420 Wp and 125 Vdc, enabling maximum DC power output based on radiation levels. This DC power is then converted to AC power by the inverter. These optimisers are configured to start early in the day, maximizing power collection.

Enphase Microinverters: Enphase microinverters have specific limitations concerning the maximum DC power module that can be connected, and the AC output limit. For instance, the Enphase IQ7 Plus, the latest microinverter, allows a maximum DC power input of 440 Wp, resulting in a maximum AC output of 295 VA (assuming a power factor of 1, the active power would be 295 W, approximately 70% of the module's maximum peak power).

The issue arises due to power clipping, where the microinverter's output is limited, causing potential loss of power generation from the modules. This limitation is not as prominent with



DC optimisers. The concept of power clipping is illustrated by curves depicting the power output from different-sized panel arrays using a smaller inverter. While the green curve (representing a larger 13.5kW array with a smaller inverter) seems slightly larger than the blue curve (10kW array with a larger inverter), the area under the green and blue curves combined is significantly larger, demonstrating the impact of matching the inverter size to the array.

In summary, power clipping can lead to the loss of potential power output from the panels when using microinverters, especially when the module's DC power exceeds the microinverter's output capacity. This issue might impact the overall system efficiency and power generation potential.

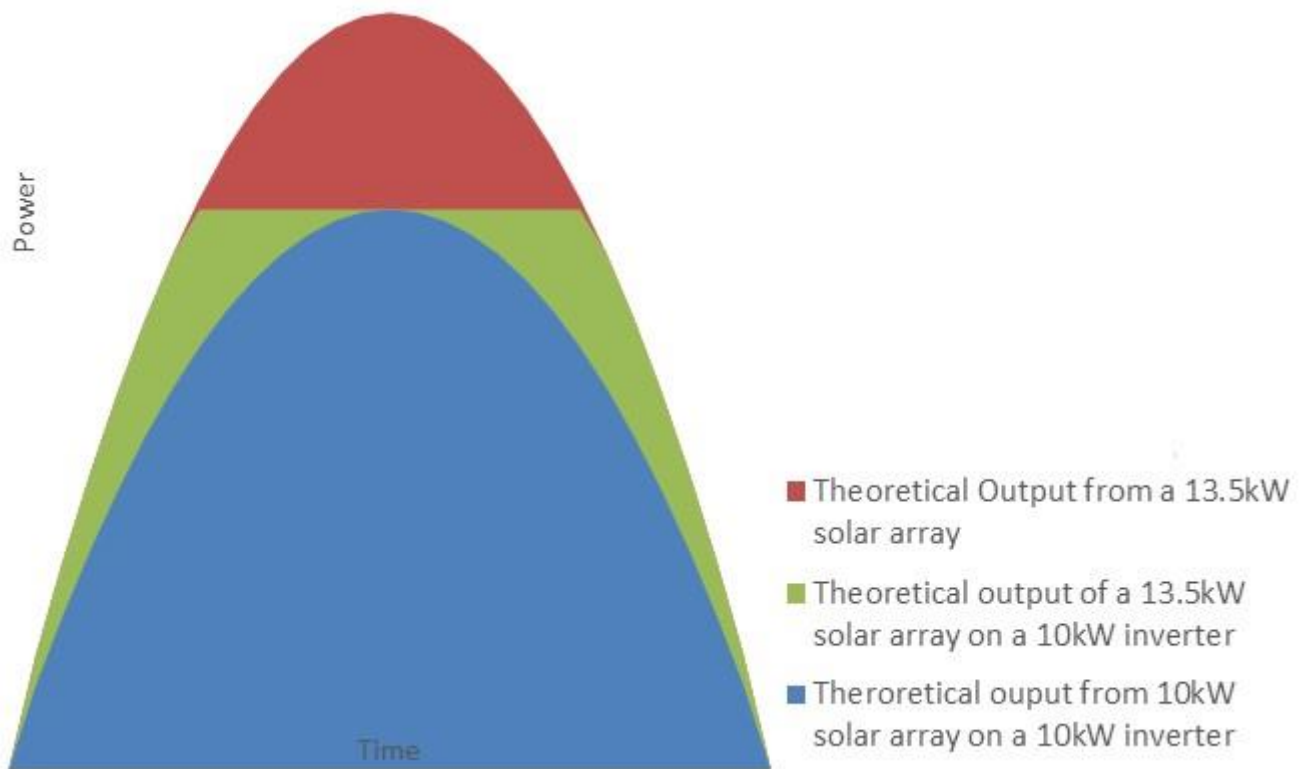

Figure: Differences between the operating modes of microinverters and DC optimizers, source: <https://newenglandcleanenergy.com/energymiser/> ;

Micro-inverters and DC Optimisers - Differences

7. Compatibility with solar batteries



DC Optimisers: DC optimisers can interface with batteries due to their DC power output, which can connect to charge controllers for battery charging purposes. The DC output from optimisers can be directed to charge controllers to charge the batteries, providing power to DC loads or the inverter. However, using batteries with DC optimisers usually requires pairing them with specific inverters like the StorEdge inverter to activate backup functionalities. Without the compatible inverter, the system will shut off during grid outages as a safety measure.

Microinverters: The AC output of microinverters presents a challenge for connecting directly to charge batteries. This limitation means that a battery-based inverter, utilizing AC to charge batteries, needs to be installed separately. Enphase offers a solution called IQ Storage, an integrated system combining an inverter and a battery of 1.2 kW standard capacity. However, the system's limitations are apparent as it doesn't support backup or off-grid capabilities. Users can only store solar energy for later use when the feed-in tariff is higher, restricting its functionality to peak-time energy usage and not for backup or off-grid purposes.

In summary, while DC optimisers allow more straightforward integration with batteries and potential backup configurations (when combined with specific compatible inverters), microinverters like Enphase IQ Storage offer a battery solution with limited functionalities and applicability mainly for optimizing energy usage during higher tariff periods rather than backup or off-grid scenarios.

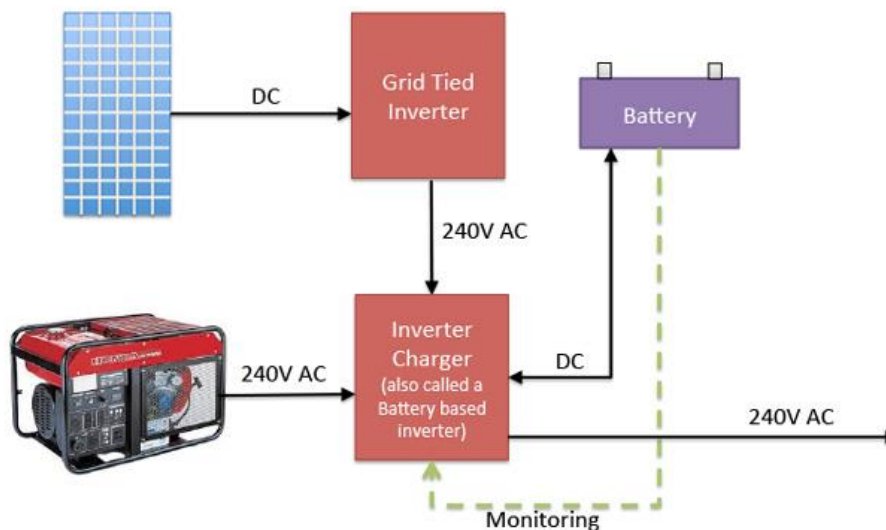

Figure: An AC coupled system using a grid tie inverter and an inverter/charger (also known as a battery based inverter), source: <https://www.solarquotes.com.au/blog/microinverters-battery-backup-compatible/>

4. Installation of a PV system depending on the purpose and according to the architectural features of the building.

Content

- 4.1. Roof-based Photovoltaic systems- Introduction.
- 4.2. Architectural types of roofs
- 4.3. Mounting solar panels on shingle roofs
- 4.4. Mounting solar panels on metal roofs
- 4.5. Mounting solar panels on tar and gravel roofs
- 4.6. Specifics of installing photovoltaic systems on building facades
- 4.7. Different Type of Building-Integrated Photovoltaics (BIPV) Technology
- 4.8. Peculiarities when installing light roof constructions - Glass roofs PV systems.
- 4.9. Installation of ground-based PV systems
- 4.10. Types of Solar Trackers systems and their pros & cons.



4.1. Roof-based Photovoltaic systems/Architectural types of roofs - Introduction.

Solar technology is incredibly versatile, finding its place in various locations, from rooftops to parking lot canopies, open fields, and even floating arrays in bodies of water. Solar panel systems generally fall into four main categories: residential, commercial & industrial, community solar, and utility-scale. While they all utilize similar technology, their distinctions lie in size, location, cost, and purpose.

Practically any building surface exposed to direct sunlight is suitable for installing photovoltaic systems, including sloped and flat roofs as well as facades. Solutions can be categorized as either additive or integrative, with the flexibility to utilize unused open spaces.

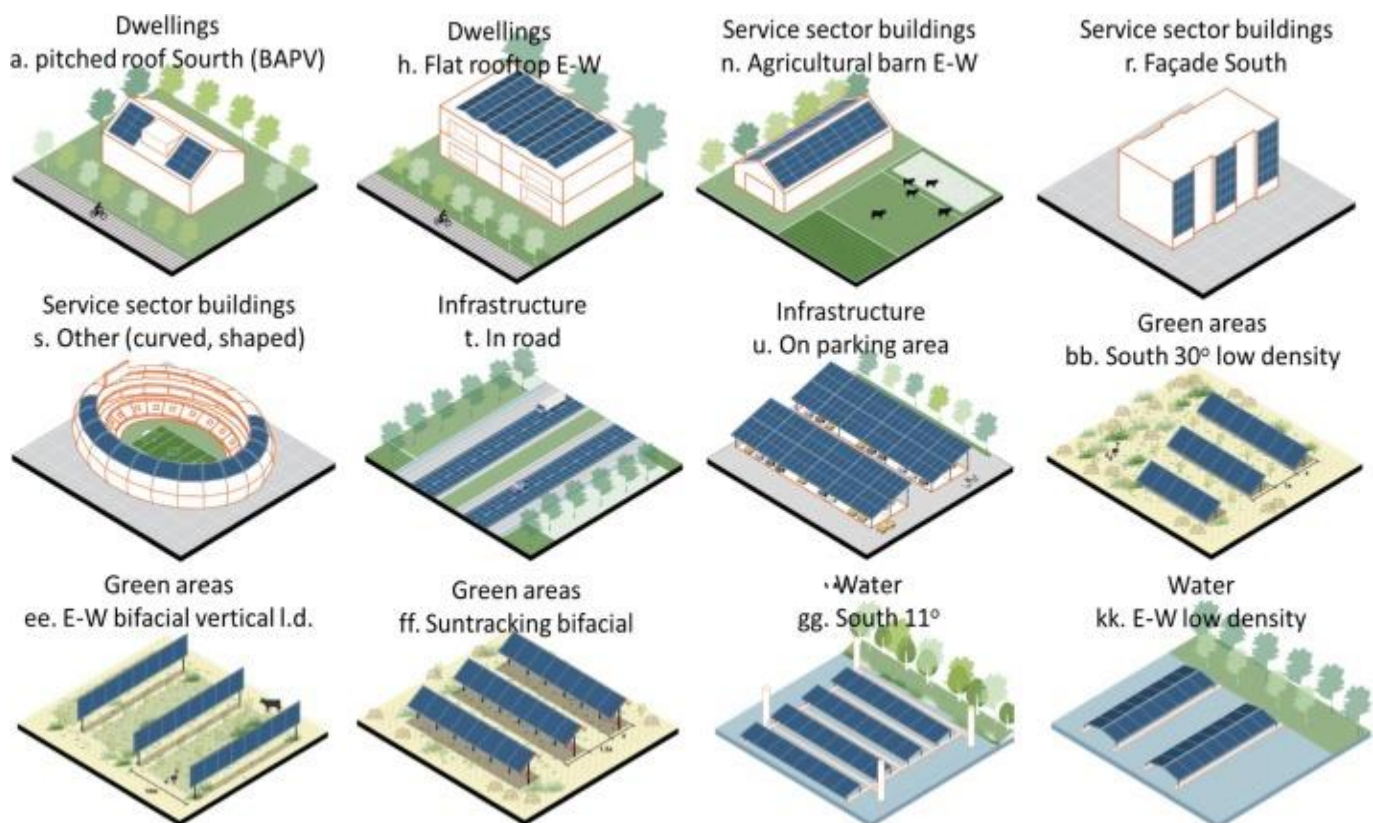

Figure: Different architectural solutions for building photovoltaic systems,
source: <https://doi.org/10.1016/j.solener.2022.07.048>

In an additive solution, photovoltaic modules are typically affixed to a metal structure atop the roof or in front of the facade, serving solely to generate electricity as an additional technical structure on the building.

Conversely, the integrative solution involves replacing components of the roof or facade with photovoltaic elements. Here, the photovoltaic system becomes an integral part of the building structure, providing not just electricity but also fulfilling functions such as weather protection, thermal insulation, noise reduction, sun shielding, and security. This approach leverages synergy effects and enables visually sophisticated integrated solutions.

4.2. Architectural types of roofs

The primary functions of a roof are not inherently linked to photovoltaics. Thus, it becomes crucial to assess how the roof's attributes impact the PV system. Equally important is to prevent any degradation of the roof's properties caused by the installation of photovoltaic panels. Understanding the structure and purpose of the specific roof is essential. Consideration should be given to the following roof-related aspects:

- ◆ **Architectural Appearance:** The aesthetic appeal of the roof.
- ◆ **Load Absorption:** Capacity to withstand forces from the roof skin, wind, rain, and snow.
- ◆ **Thermal Protection:** Capability to provide heat insulation.
- ◆ **Acoustic Insulation:** Capacity to reduce sound transmission.
- ◆ **Fire Resistance:** Ability to block fire for enhanced fire protection.
- ◆ **Design Elements:** Includes shape, color, material, and surface structure.

The properties mentioned must not be impaired by the photovoltaic system.





Figure: The properties of the roof and the PV system. source: <https://www.rikurenergy.com>

4.2. Architectural types of roofs

Roofs can be broadly classified based on their pitch:

- Flat Roofs: Inclination less than approximately 5°
- Flat-Pitched Roofs: Inclination ranging from 5° to 22°
- Normal Pitched Roofs: Inclination between 22° to 45°
- Pitched Roofs: Inclination greater than 45°

Generally, all roof surfaces except those facing north are viable for solar energy utilization. Curved surfaces, owing to varying angles of inclination and possible orientations, create diverse irradiation conditions within the PV generator. It's crucial to consider these variations when connecting the strings to ensure optimal energy yields.



Roofs exhibit diverse styles and materials, each influencing the installation of solar panels differently. Understanding these nuances is vital when planning solar panel integration.

Different Types of Roofs

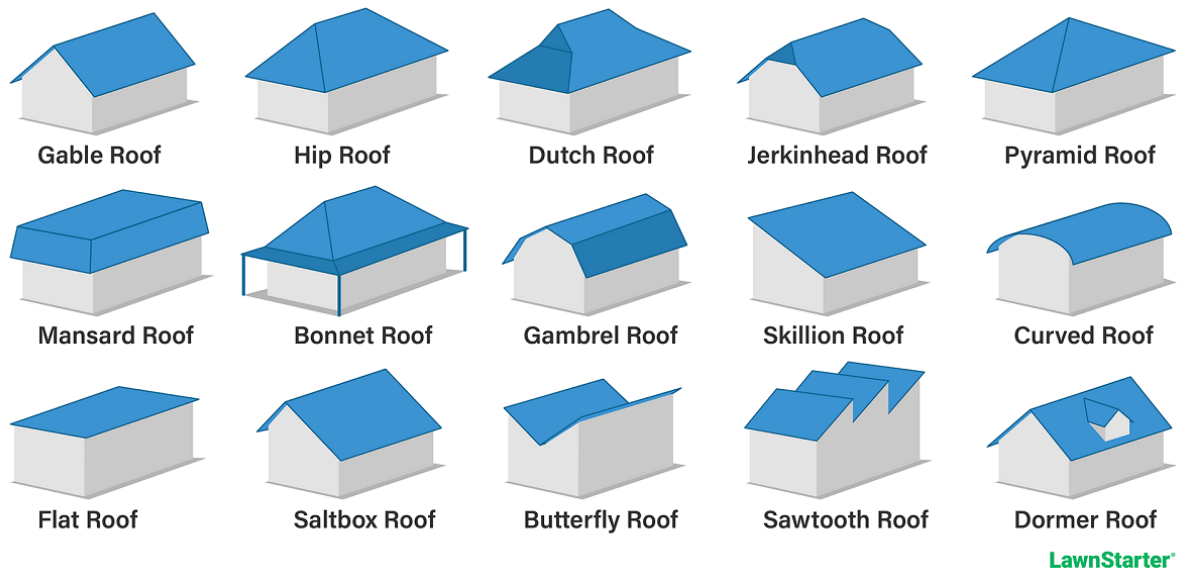

Figure: In architecture there is a great variety of different types of roofs,
source: <https://www.lawnstarter.com/>

4.3. Mounting solar panels on shingle roofs

PV panels on shingle roofs

Shingle roofs, primarily composed of composite or asphalt shingles, are the most prevalent roofing types in homes. Their popularity stems from being cost-effective, durable, with a lifespan ranging from 12 to 20 years, making them an ideal base for solar panel installation that may remain in place for decades.

Tips for *Installation* on Tile Roofs

Composite shingles incorporate various materials like laminate, wood, and slate, while asphalt shingles are composed of either a cellulose mat or fiberglass material combined with asphalt during the final production stages. Among these, composite shingles generally exhibit greater durability compared to their asphalt counterparts.



The process of installing solar panels on shingle roofs is straightforward, involving standard penetrating mounts for attachment. Installation necessitates drilling studs into the roof to affix the solar panels. To prevent water seepage between the panels and studs, crucial flashings seal off these spaces, safeguarding against potential leaks into the home.



Figure: Mounting PV panels on shingle roofs,

source: <https://www.solarpowerworldonline.com/2015/09/eight-tips-for-mounting-solar-on-tile-roofs/>

4.4. Mounting solar panels on metal roofs

PV panels on metal roofs

Metal roofs present an ideal substrate for installing solar panels, especially those with standing seams. Their design eliminates the need for drilling during panel attachment, reducing labor costs in the installation process.

Moreover, metal roofs have a cooling advantage; they reflect solar radiation not captured by solar panels, helping maintain a cooler home environment.



These roofs boast an impressive lifespan, ranging between 40 to 125+ years, making them a durable choice for homeowners.

Vertical seam panels, commonly found in flat metal panel roofs with seams running along the roof at regular intervals, offer versatile options for solar panel integration.

However, it's worth noting that metal roofs tend to be pricier compared to other roofing materials. Additionally, during adverse weather, they can produce higher noise levels. Fortunately, the installation of solar panels helps mitigate some of this noise.

Here are five key advantages to consider when installing PV panels on a metal roof:

1. Easy mounting process for solar panels on metal roofs.
2. Metal roofs accommodate both thin film panels and standard photovoltaic panels.
3. Durability of metal roofs often surpasses the lifespan of solar panels.
4. Solar panels enhance the cooling benefits of metal roofs.
5. The combination of metal roofs and solar panels contributes to an eco-friendly home.

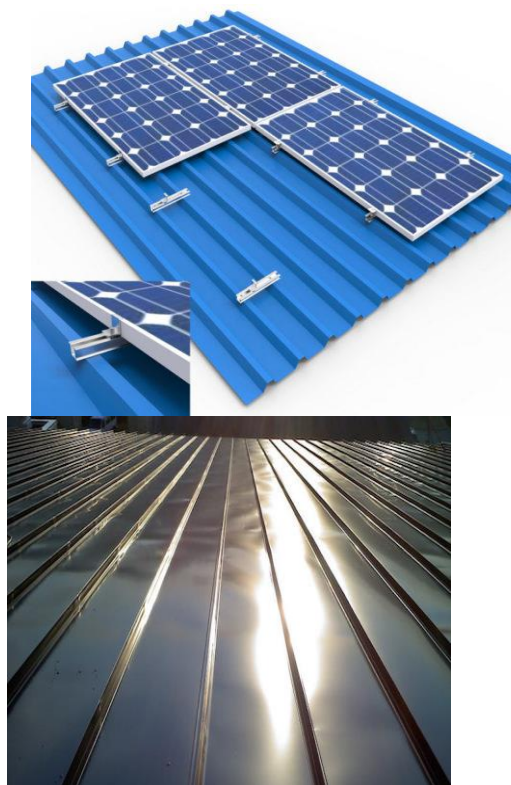

Figure: PV panels on metal roofs, source: <https://www.solarpartscomponents.com/metal-roof-solar-mounting-systems-u-rail>

Mounting solar panels on tile roofs

Clay tile roofs are a prevalent roofing style in Central and Southern Europe.

Historically, installing solar panels on clay tile roofs was considered more complex and risky compared to other roofing types, like composite shingles or metal roofs. The fragility and relative expense of clay tiles, along with the risk of compromising the roof's waterproofing, posed challenges during installation.

Some solar installers employ a technique known as a "comp-out" to simplify solar installations on clay tile roofs. This method involves replacing the clay tiles beneath the designated solar panel area with composite shingles. Once the shingles are in place, traditional solar roof mounts, rails, and panels can be installed.

The installation process typically involves removing tiles in the target area, attaching brackets securely to the roof's structure (such as rafters or RCC roof), and then re-installing the tiles. The solar panel railing systems are affixed to the steel brackets, creating a gap between the roof and the panel. This space allows for crucial air circulation, preventing overheating of the solar panels during hot summer months. In the case of RCC roof, a drilling depth of 50mm is necessary.

The solar panel mounting system utilizes rails and brackets to secure the solar power system to the roof frame, distributing the weight of the panels evenly across the covered area. While robust, the panels are relatively lightweight, with the combined weight of panels, brackets, and frame averaging around 13kg per square meter of roof spa

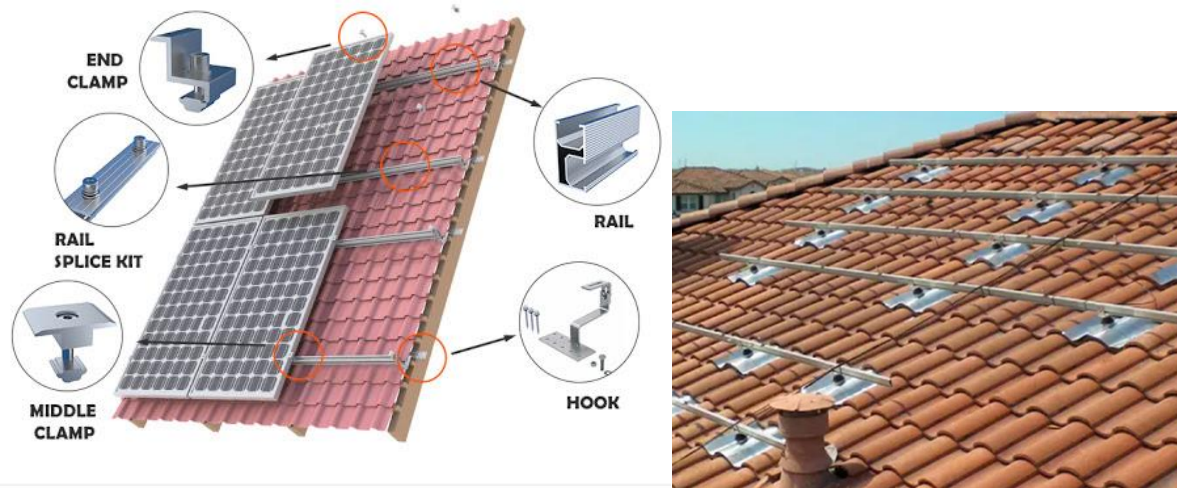

Figure: Installation of photovoltaic panels on tile roofs, source: <https://blog.gogreensolar.com/installing-solar-panels-spanish-tile-roof>

4.5. Mounting solar panels on tar and gravel roofs

Mounting solar panels on tar and gravel roofs

Tar and gravel rooftops are favored by many homeowners due to their cost-effectiveness and relatively long lifespan of about 20 to 25 years. These roofs are tightly sealed to prevent cracks and leaks and offer a flat, stable surface for solar panel installation. Ideal for hot and dry climates, the tar and gravel roof membrane use hot tar and roofing felt for sealing, with a layer of crushed rock aiding in preventing sun damage.

The primary function of a roofing system is to safeguard what lies beneath it. Understandably, both building owners and installers are hesitant to puncture this multi-layered protective system, which could potentially void the roof warranty. While ballast systems do not penetrate the roof, they come with certain drawbacks.

Strengthening the system with concrete blocks is one approach to counter these disadvantages. However, the labor involved in moving these blocks to their designated location is considerable. Ballast adds significant weight to the roof, sometimes surpassing the building's structural capacity in a 100% ballast PV system. Misplaced ballast blocks can abrade the roof membrane, compromising the waterproofing layer intended to remain intact.

Moreover, without a protective roofing sheet or a solid layer over the insulation, ballast can compress the insulation, creating depressions that may collect water and dirt. This can potentially harm the membrane and void the warranty. The natural expansion and contraction of the metal frame during thermal cycling can also present issues.



Figure: PV system on one tar and gravel

roofs, source: <https://www.greentechrenewables.com/customer-project/235kw-sunny-sausalito-ca-solar-install>

Mounting solar panels on tar and gravel roofs

When designing and installing a photovoltaic (PV) system on a roof with tar and gravel covering, it is essential to adhere to specific requirements:

1. **Secure Waterproof Fixing:** Ensuring the solar panels are securely and watertight fixed to the roof surface is critical to prevent leaks and potential damage.
2. **Water Resistance:** The installation should not impede water flow, preventing debris accumulation and the creation of ponds or lakes on the roof surface.
3. **Accurate Load Calculation:** Any additional weight added by the solar panel system must be precisely calculated to layout the fixing elements effectively without compromising the roof's structural integrity.
4. **Avoiding Perishable Materials:** The use of adhesives or mastics prone to deterioration should be avoided, ensuring longevity and reliability of the installation.
5. **Manufacturer and Contractor Approval:** Prior approval and oversight from the roofing system's manufacturer and contractor are essential to safeguard the roof warranty.

There are engineered solutions specifically designed for fixing solar panels on flat roofs. One such solution is the IFP from Nicholson, featuring a low-profile, puck-shaped stainless steel fixing point. This fixing point comes with a factory-fixed membrane flange, with the specific membrane type designated during the specification of the fixings. The installation involves fixing the point to the structural roof deck through the insulation, limiting the penetration points to factory-produced areas. This approach allows roofing contractors to weld the membrane flange consistently, utilizing their existing skills.





Figure: One engineering solutions for fixing PV arrays on flat roofs,
source: <https://www.singleply.co.uk/fixing-solar-panels-to-flat-roofs-why-we-recommend-an-engineered-solution/>

Benefits of the IFP Solution:

- Compatible with bituminous and single-ply membranes (PVC, TPO, EPDM, PIB).
- Low-profile, standing 45mm above the finished roof surface.
- Applicable with direct or thermally broken fixings.
- Allows direct fixing to the roof structure with calculable pull-out value for precise design of fixing layouts.
- All fixing points are beneath the membrane.
- Covered by roofing system warranty where approved.
- Offers universally accepted M10 anchor points, ensuring ease of use.

Mounting solar panels on tar and gravel roofs

Two Engineered Solutions for fixing solar panels to flat roofs

Solar Panel Support Post™ by Latchways





Figure: One engineering solutions for fixing PV arrays on flat roofs,

source: <https://www.singleply.co.uk/fixing-solar-panels-to-flat-roofs-why-we-recommend-an-engineered-solution/>

1. Solar Panel Support Post™ by Latchways

The Solar Panel Support Post, developed from Latchways' Constant Force® post technology utilized in their award-winning ManSafe® fall protection system, comprises a coated aluminium baseplate and body, alongside an electro-polished stainless steel dome with stainless steel fixings. The specifier selects an approved membrane, and the baseplate and body undergo specialist coating in the factory, tailored for use with the chosen membrane, allowing hot air welding on site post-installation.

Benefits:

- ✧ Suitable for bituminous, PVC, and selected FPO/TPE single-ply membranes, as well as standing seam and secret fix roofing.
- ✧ Utilizes innovative Constant Force post technology with over 12 years of proven use.
- ✧ Each post can resist a maximum tensile, shear, and imposed load of 2.5 kN.
- ✧ Designed for a lifespan of over 20 years.
- ✧ Incorporates the Latchways Overload™ feature to indicate excessive uplift in the PV array and safeguard roof membranes during uplift incidents.
- ✧ Can be installed and inspected simultaneously with a ManSafe fall protection system if both systems are installed together.

Conclusion



When installing solar panels on various roof types, specific expertise is necessary. Based on the information provided, metal roofs with standing seams on structural components are the easiest to install. They are cost-effective and may not require additional sealing to prevent water seepage.

Concerns about potential roof damage caused by solar panels are valid. It's crucial to review the manufacturer's warranty or recommendations before installation. Additionally, consulting your local building inspectorate or authority for regulations pertaining to solar panel installations on different roof types is advisable.

4.6. Specifics of installing photovoltaic systems on building facades

Facade PV systems

Photovoltaic (PV) technology has found versatile applications in architectural facades, offering distinct advantages over traditional roof-mounted solutions. While facades may receive lower radiation and yield compared to optimally inclined roofs, integrating PV elements into facade designs proves advantageous. Substituting expensive facade materials, like natural stone or stainless steel plates, with photovoltaic elements incurs minimal additional costs, rendering the system economically compelling.

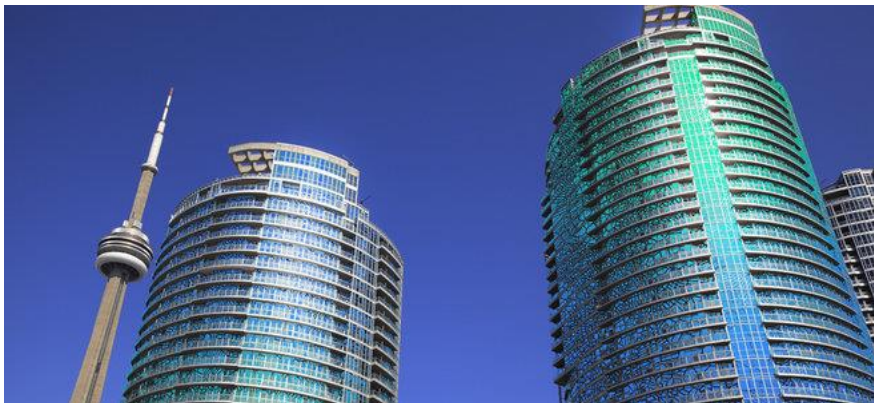

Figure: Two examples of facade architectural solutions of PV systems,
source: <https://www.reminetwork.com/articles/benefits-of-building-integrated-photovoltaics/>; <https://evershinesolar.com/building-integrated-photovoltaics-bipv/>

The advent of Building Integrated Photovoltaics (BIPV) in the 1990s marked a significant milestone, introducing products explicitly designed as part of the building envelope. Recent technological strides have further simplified the creation of architectural designs seamlessly integrating solar energy collection into building structures.

The initial investment in BIPV is balanced by reductions in expenses for conventional building materials and labor typically used in construction. Once operational, solar energy



generated from sunlight yields ongoing savings. These financial benefits fuel BIPV's rapid growth in the photovoltaic industry.

Various building components—spandrel glass, skylights, roofs, windows, and facades—easily lend themselves to substitution with photovoltaics in BIPV applications. Unlike mere add-ons, BIPV systems blend seamlessly with the building's structure and aesthetics.

Modern advancements facilitate curved surfaces and transparent modules, transforming building design. BIPV systems can either harmonize with traditional building materials or manifest a sleek, high-tech appearance, catering to diverse client preferences.

Semi-transparent modules have emerged, replacing conventional glass elements such as windows and skylights. Solar cells seamlessly integrate into facades, complementing or replacing traditional view or spandrel glass.

New technologies enable retrofitting facades on existing buildings, providing a fresh aesthetic. These retrofit modules, applied onto the building's facade atop the existing structure, enhance the building's appeal and resale value. This retrofit method, termed Building-Applied Photovoltaics (BAPV), breathes new life into established structures.

Facade PV systems

The modules used open up a multitude of design options. They can be manufactured in any shape and size and equipped with all optical and functional product properties of glasses. The photovoltaic elements are attached like conventional glasses. Single or multi-sided storage is just as possible as point attachments or glued assembly in structural glazing systems.

When designing and installing it is necessary to consider the possibility of replacement in case of failure, care should be taken with PV modules that the lines, electrical connections and bypass diodes are easily accessible and easy to solder.

Photovoltaic modules can be very easily attached to existing facades.

This is, for example, the option of using protective walls or windowless facades on large industrial and commercial sites. When there are no special requirements for the shape and dimensions of the modules, it is possible to use standard modules. As the modules do not have to provide weather protection, they can be assembled freely, for example to create inscriptions and emblems for advertising purposes or simply to create models in the sense of "solar art". The usability of the modules according to the construction law and electrotechnical national standards and regulations in these cases must be strictly observed.





Figure: PV plant on the façade of an industrial building,
source: <https://www.solar mango.com/dictionary/bipv>

BIPV is still an emerging segment in PV systems. Products in this segment are based on either thin-film or crystalline technologies. It's better to choose thin-film technologies while integrating them in buildings. This is because of thin-film technologies offer better aesthetic and flexible structural characteristics.



Figure: Building-integrated photovoltaics produced by Mitrex.



source: <https://urbantoronto.ca/news/2021/10/making-construction-industry-more-sustainable-integrated-solar-technology>

Facade PV systems

The new City Hall in Freiburg (Germany) – one of largest solar glass facades in Europe

The company a2-solar designed and supplied the solar modules for the facade of this unique European project.

With a surface area of approximately 13,000m², the energetically optimized facade has been designed by the renowned architects at Ingenhoven Architekten and executed in close cooperation with the metal construction company HW Würfel Metallbau and a2-solar. The facade consists of metal frames aligned towards the sun, for which the solar modules have been specifically customized by a2-solar (see figure). Figure: The new City Hall in Freiburg (Germany), source: Archdaily

The overall output of 220kWp is generated by a total of 880 solar modules, which a2-solar has manufactured as special seamless double-glass modules with exceptional dimensions of 3.5m in height and 60cm in width, weighing almost 100kg each. Thanks to this innovative solar facade, this new municipal building fulfills all of the EnEV requirements as one of the first public buildings. This City Hall completely aligns with the principal standards of a zero-energy building. The “green building” concept with 100% energy self-sufficiency, however, was only successfully achieved by using the facade surface in addition to the photovoltaic rooftop system. Also, the Fraunhofer Institut für Solare Energiesysteme (ISE) validates this project for its holistic characteristics of sustainability and integrity.



Figure: The new City Hall in Freiburg

(Germany), source: <https://www.archdaily.com/885885/freiburg-town-hall-ingenhoven-architects>

Module details:

Size: 594mm x 3494mm

Technology: Glass-Glass (2 x 5mm)

Output: 245 Wp

Building facade made of vertically integrated, semi-transparent solar panels, which are installed on sun-exposed frontiers. Due to the ENEC regulations, all buildings and facades are to be equipped with energy-saving components in the future.

Solar Balcony Railings

Solar panels are not limited to rooftops and building facades; they can also be integrated into balcony railings, offering a complementary solution. While each product has its advantages and drawbacks, solar panel railings can enhance overall efficiency when combined with other solar solutions.

The cost of railings constitutes a relatively small percentage (about 1-2%) of a project's total expenses. Incorporating solar panels into balcony railings doesn't significantly impact the overall cost of a construction project, considering the necessity of balcony railings.

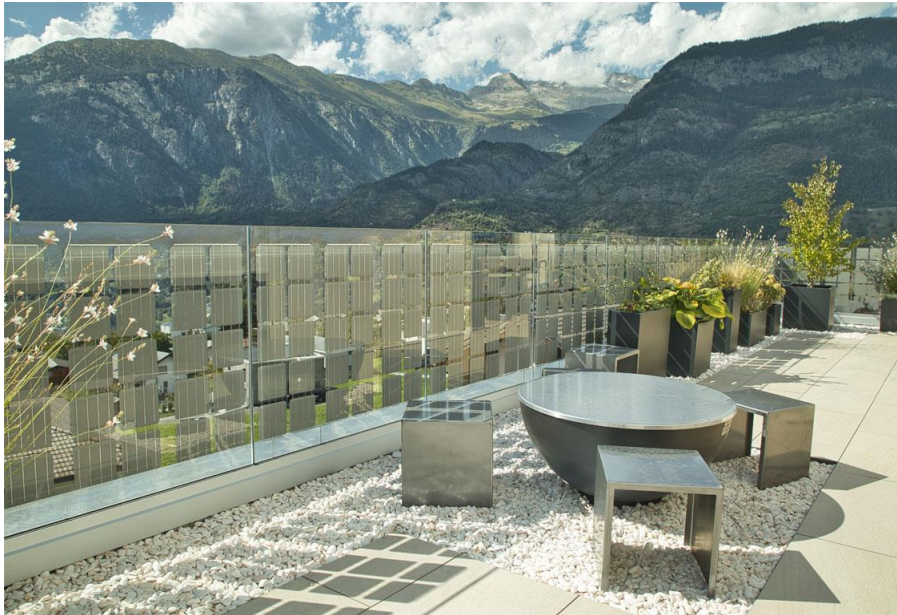

Figure: PV loft in the Swiss Alps town of Thermen, source: <https://a2-solar.com/en/solar-modules-for-solar-attika-in-switzerland/>

The solar railing featured above consists of 32 modules (including 1 dummy module) with sizes ranging from 1200mm x 1147mm to 1665mm x 1147mm, utilizing 2x10mm double glass technology. These modules were elegantly mounted on a simple aluminum floor rail without a top-mounted handrail, creating a seamless and modern look. Designed as 30, 35, and 40 cell modules with 5mm spaces in between, the entire solar balcony system achieves an output of approximately 3.7kWp. Thanks to its favorable location, snow reflections, and weather conditions, this solar system can yield up to 5,500kWh annually.

When combined with a rooftop system, the solar power generated covers the electricity needs of the ownership community (5 parties) and is stored in a 13.6kWh storage system. Any surplus solar power is fed directly into the public grid.

Solar Balcony Railings

Contemporary photovoltaic (PV) modules, readily available in the market, are transforming balconies into innovative and profitable "solar power plants." These installations not only meet current energy-saving regulations but also adhere to the highest aesthetic and architectural standards. The notion that photovoltaic systems are restricted to roofs or solar parks is now a thing of the past.





Figure: One intelligent solution has been realized at an object in the Swiss city of Bern, source: <https://a2-solar.com/en/a2-delivers-solar-modules-for-solar-balcony-power-plant-in-switzerland/>

An intelligent solution was implemented in a project located in the Swiss city of Bern, commissioned by swissREnova, a construction company in Bern-Münsingen, Switzerland, emphasizing sustainability and energy efficiency. The renovated residential building, constructed in 1963, now complies with passive house standards, requiring 80 to 90 percent less heating energy than conventional buildings.

The solar modules installed not only generate electricity but also fulfill the highest aesthetic and architectural requirements. Offering various transparency options and color variations for cells, glasses, and embedding foils, these solar modules can be tailored to individual customer preferences, aligning the appearance of photovoltaics with the technical "frame" and the environment.

A total of 240 modules with a height of 1,090 millimeters and various widths from 1,407 to 1,767 millimeters were installed, yielding an output of 46 kWp and generating up to 30,000 kilowatt-hours of electricity (kWh) per year for own consumption.



Mono-crystalline solar cells, laminated between two 4mm thick, partially tempered safety glasses, were utilized. The minimized distance between the cells and towards the edges reduces transparency, offering privacy by allowing a view from the inside to the outside but not vice versa. The front glass, made of structured glass with a dot silk print, along with a grey embedding foil, imparts a special golden coloring to the elements, making the parapets virtually indistinguishable as solar modules from the outside.

This approach extends beyond commercial and industrial halls, demonstrating that multi-story residential buildings are also suitable for this form of energy generation due to their ample usable surfaces—particularly on façade or parapet surfaces. The primary driver is the pursuit of greater energy efficiency, given that buildings alone account for nearly 40% of total European energy consumption. The building sector holds significant potential for energy savings, surpassing current estimates

4.7. Different Type of Building-Integrated Photovoltaics (BIPV) Technology

BIPV systems can be incorporated during the construction phase of a building or integrated into existing buildings during renovations when one of the envelope components requires replacement.

The built environment offers various possibilities for BIPV integration, focusing on three primary application areas:

- ✧ Roofs (e.g., tiles, shingles, skylights)
- ✧ Facades (e.g., cladding, suspended facades, windows)
- ✧ Externally integrated systems (e.g., balcony railings, shading systems)

BIPV products available on the market typically utilize either crystalline silicon (c-Si) based solar cells or thin-film technologies, including amorphous silicon (a-Si), cadmium telluride (CdTe), and copper indium gallium selenide (CIGS).





Figure: Public Library with Solar Facade, source: <https://www.mitrex.com/technology/>

Photovoltaic products are strategically designed to permit sunlight to pass through the surface and reach the solar cell, where it is absorbed to generate energy. Various proprietary coatings ensure seamless aesthetics and long-lasting solar materials while still producing energy.

These coatings, embedded in the panel's facing layer, protect against scratches or damage. Specially designed layers absorb all wavelengths except those in the visible range of the electromagnetic spectrum, striking a balance between color design and PV panel efficiency.

While a small percentage of the sunlight's energy is reflected, the majority is absorbed by the solar cell, generating electricity. The coatings enable customized finishes to meet design requirements while maximizing energy production.

The windshield of a PV panel is obtained by combining two different surface treatments:

- ✧ A multi-layer coating is deposited on the inner glass surface by low-pressure plasma processes. Its constituent materials are exceptionally characterized by high solar transmittance, minimal absorption and high durability, while maximizing high angular color stability. No pigments or colorants (paint) are used so that the color does not fade over time or due to exposure to the sun.



- ✧ The treatment of the outer glass surface results in diffuse reflection. This prevents glare and reinforces the masking effect of the technical parts of the solar devices, further improving the aesthetics.

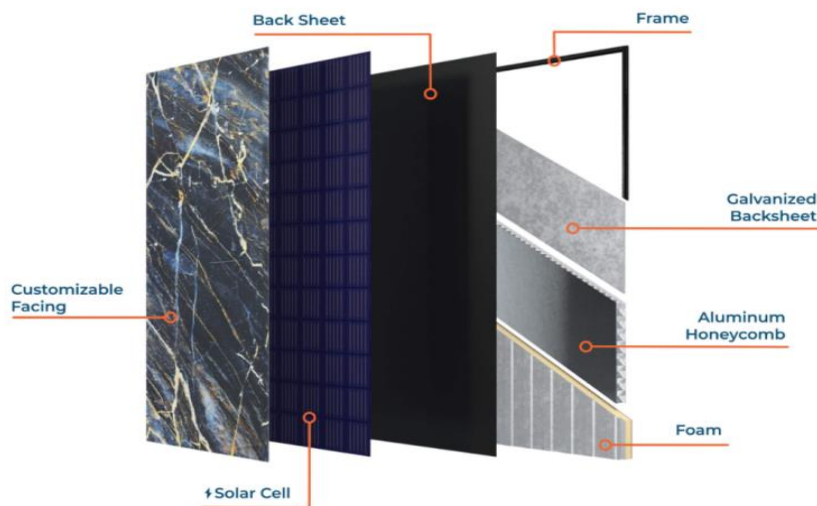
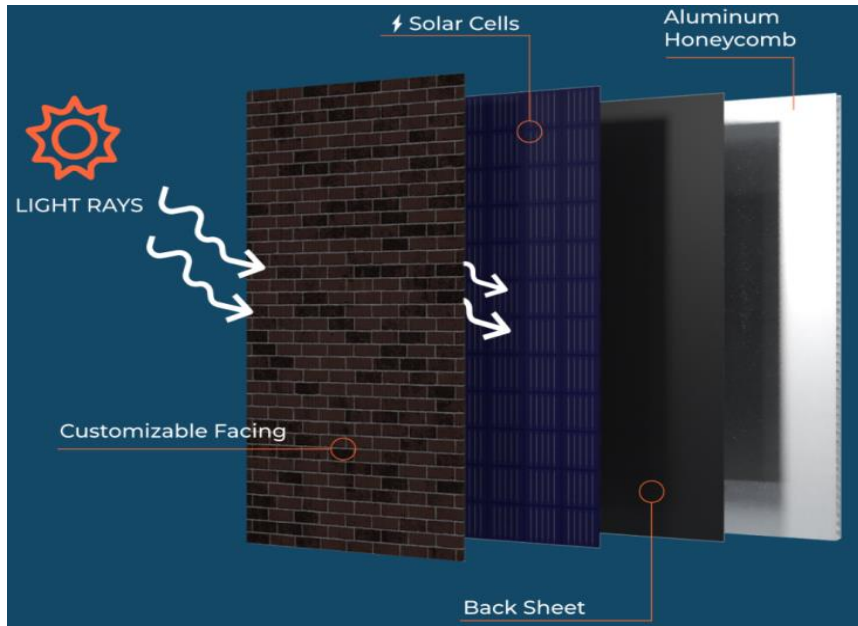

Figure: Architecture of colored photovoltaics, source: <https://www.mitrex.com/technology/>

Photovoltaic panels based on this technology are available in different colors. No dyes or tints are used to color the glass, which is why it remains stable over time and exposure to the sun and thanks to its unique technology. Its average transmittance is between 85% and 90%



depending on the color. Colored solar glass is produced in various sizes and thicknesses, it can be processed in the same way as standard solar glass to suit the customer's production process.



Figure: A different customizable designs and patterns, source: <https://www.mitrex.com/solar-facade/>

The tempered glass is also just as strong as traditional facade materials such as aluminum and concrete and resists being marred, scratched, and pitted by the elements. The treatment of the outer glass surface results in diffuse reflection. This prevents glare and reinforces the masking effect of the technical parts of the solar devices, further improving the aesthetics.

These patterned colored PV panels feature UV-stable, fade-resistant colors. This guarantees energy production for many years.

BIPV System Components

PV Modules (BIPV) seamlessly integrate into the building. The module mounting technology is straightforward, and the wiring is invisibly embedded to maintain a unified facade design. The schematic diagram of the BIPV system is illustrated in the figure below. It incorporates a quick disconnect device, optional PCS controllers, optional battery storage system, inverter, transformer, and switchgear. Additional monitoring software can be added to the system for easy tracking.



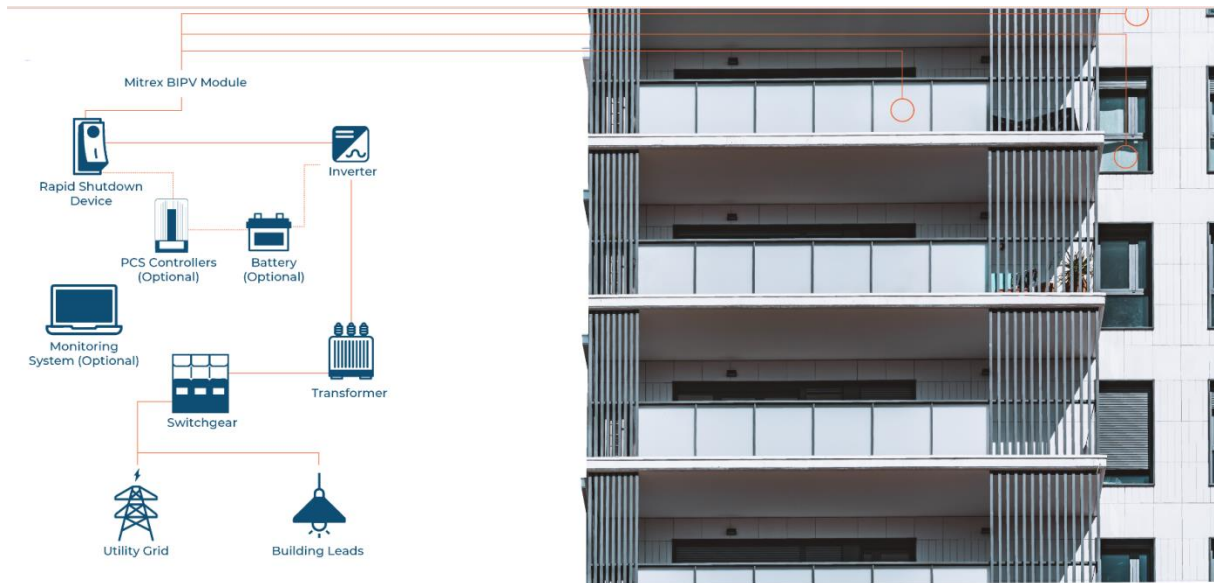

Figure: A schematic diagram of the BIPV system, source: <https://www.mitrex.com/technology/>

Each Mitrex panel features two MC4 connectors on the back. These connectors are linked together in strings that run down a conduit into the building's electrical room, supplying power to the BIPV system's inverters. The maximum number of panels per string is determined by the allowable voltage in the building and the size of the solar panels.



Figure: Connectors connected together in strings, source: <https://www.mitrex.com/technology/>

The available PV modules for this technology have thickness options within the following limits:

Glass / Backsheet

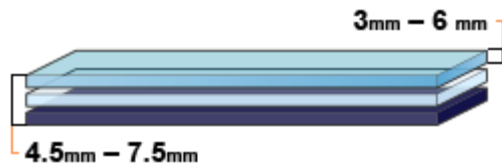

Glass thickness: 3mm – 6mm
Module thickness: 4.5mm – 7.5mm
13.5mm

Glass / Glass

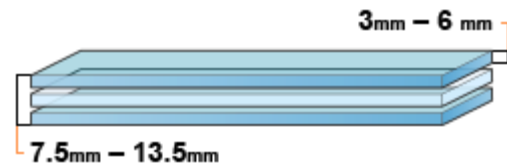

Glass thickness: 3mm – 6mm
Module thickness: 7.5mm –

4.8. Peculiarities when installing light roof constructions - Glass roofs PV systems.

Solar carports

Solar carports are a specific type of solar structure, falling under the broader category of solar carports. Also known as solar awnings or solar pergolas, they are designed to provide shade, especially for parked cars and other motor vehicles.

Solar panel sheds are gaining popularity among businesses and public spaces, harnessing solar energy to power vehicles. As awareness of the potential benefits of these solar canopies grows, there is increasing interest in how they will shape the future of modern parking lots.



Figure: A Solar carport, source: <https://a2-solar.com/en/building-integrated-pv/solar-carports/>

Advantages of investing in solar canopies for parking:

1. Substantial energy savings
2. Reduced maintenance costs for parking lots
3. Decreased carbon footprint
4. Effective utilization of space
5. Easy integration of electric vehicle (EV) chargers
6. Maximization of currently available land.



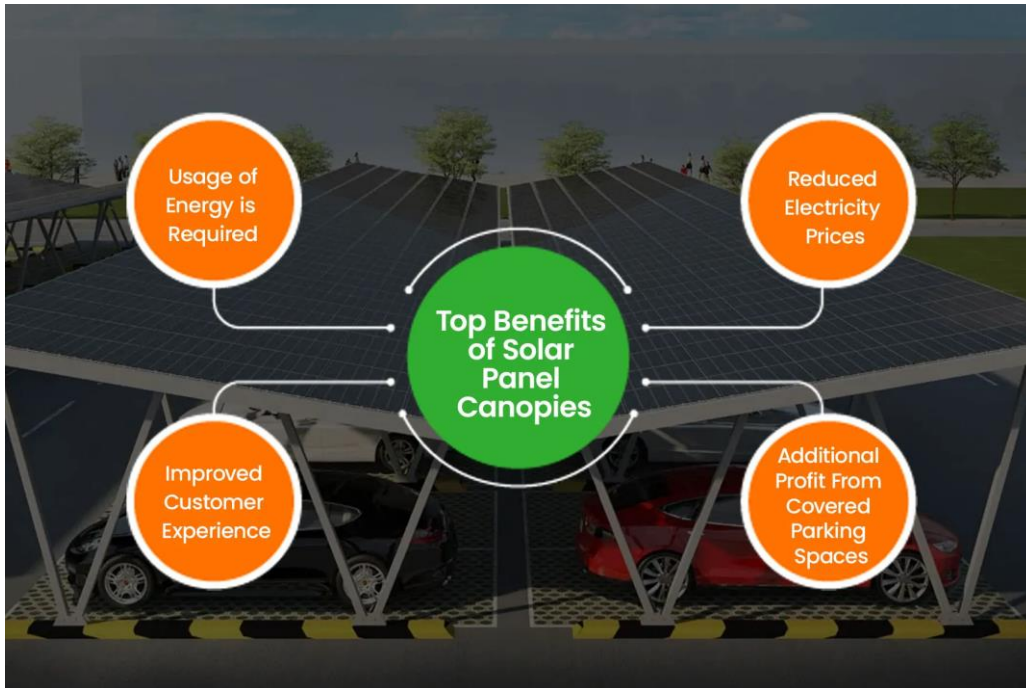

Figure: Top benefits of solar panel canopies

Benefits of Solar Carports

Efficient Space Usage: Solar carports optimize existing spaces for increased productivity and comfort. They shield vehicles from the sun, preventing overheating, and offer protection during adverse weather conditions. The shade provided by solar carports can positively impact a car's fuel economy by preventing it from getting too hot in the sun.

Cost Savings: Solar carports, akin to rooftop and ground-mount solar systems, reduce energy costs, leading to significant savings for businesses and residences. These structures contribute to financial savings by lowering energy expenses and offering potential opportunities for

power credits or selling excess energy bac



k to the grid.

Figure: An example of solar carports are solar panels mounted over car parking spaces in an urban environment. source: <https://www.mbtenergy.com/solar-panel-racking-system-solution/pv-solar-carport-mounting-system-solution>

1. **Easy to Maintain Comfort:** Solar carports are relatively easy to maintain compared to conventional structures. They help manage parking lots by diverting rain and snow away from vehicles. This not only simplifies maintenance but also enhances safety by reducing ice accumulation. The accessibility of solar panels makes maintenance straightforward.
2. **Protection:** Beyond generating solar energy, carports offer secure parking spaces. They provide protection from inclement weather conditions, such as snow or intense sunlight. The shaded areas contribute to a cooler environment, potentially reducing fuel costs. Additionally, they can aid in rainwater collection.
3. **Better Power Generation:** Solar carports offer advantages in power generation due to their adaptable installation angle. Unlike roof installations with limitations on tilting and direction, solar carports can be strategically designed to maximize sun exposure and energy output. This flexibility enhances overall power generation efficiency.

Solar systems for passenger trailers.

The passenger trailers, designed and manufactured by the Dutch company SOIOS, are equipped with a2-solar's special flat translucent solar roof modules that allow the shuttle to run on the inexhaustible energy of the sun - an ideal solution for moving up to 90 people or bulk cargo in an environmentally responsible manner even in hilly areas. If necessary, the batteries can be further topped up using green alternating current. The result: a surprisingly long daily range of up to 300 km (187 miles). As they are virtually maintenance free (which



applies to engines, batteries, chassis, body and interior) with excellent handling both on and off road, these vehicles are ideal for use in amusement and holiday parks, zoos, outdoor museums, coastal boulevards, airports and parking lots. Compliant with all technical requirements and safety rules for use on public roads, these SIOS trains are already in use throughout Europe



Figure: A PV shuttle express, source: <https://a2-solar.com/en/solar-shuttle-express-movin-sunshine/>

Additional benefits of a solar shuttle:

- ✓ Silent, clean and emission free
- ✓ Low energy costs
- ✓ Very low maintenance

Technical data

- ✓ 1 hour of solar power = 10 km (6 miles) additional range
- ✓ Transportation of up to 90 persons



- ✓ Very low maintenance

4.9. Installation of ground-based PV systems

Advantages of Ground Solar Energy

1. **Maximized Sunlight Exposure:** Ground-mounted solar panels offer the flexibility to choose the optimal orientation for maximum sunlight exposure. Unlike rooftop installations, where orientation is limited by the structure, ground-mounted systems can be strategically placed for increased energy production.
2. **Enhanced Efficiency:** These systems often operate more efficiently as they benefit from increased air circulation beneath the panels, preventing them from overheating. Improved efficiency contributes to higher overall energy production.
3. **Ease of Maintenance:** Ground-mounted systems are easily accessible, simplifying maintenance tasks. Installers can reach the components more conveniently, potentially reducing labor costs associated with maintenance.



Figure: Ground Photovoltaic System, Source: <https://news.energysage.com/ground-mounted-solar-panels-top-3->

Disadvantages of Ground-Mounted Solar:

1. **Land Usage:** Ground-mounted systems require open land, which may be a challenge for homeowners with limited available space. This can be a drawback for those who use their land for other purposes, such as gardening, recreation, or farming.
2. **Vulnerability to Damage:** Free-standing solar panels are more exposed to potential damage from wildlife or tampering by people. The lack of elevation makes the equipment more accessible and susceptible to interference.
3. **Higher Cost:** Ground-mounted solar systems tend to be more expensive compared to rooftop installations. This is especially true if the roof structure doesn't require extensive repairs to accommodate rooftop solar. Ground-mounted systems may incur higher upfront costs.



In summary, while ground-mounted solar systems offer advantages in terms of orientation, efficiency, and maintenance, they may not be suitable for everyone due to land usage constraints, vulnerability to damage, and potentially higher costs.

What is a ground-mounted solar panel?

Ground-mounted solar panels are solar energy systems installed at ground level, functioning similarly to rooftop solar systems. They harness sunlight to generate electricity through solar cells, contributing to powering buildings or communities. The panels are positioned several inches to feet above the ground, offering flexibility in terms of panel size and orientation.

Key Characteristics:

1. **Location Flexibility:** Ground-mounted systems can be installed in areas with good sun exposure and sufficient open space, requiring a minimum of around 350 square feet.
2. **Module-Level Power Electronics:** Components for fast shutdown, such as module-level power electronics, are attached to the panels. Other system components, like string inverters, can be located at a distance to accommodate temperature-sensitive equipment.
3. **Panel Size Variety:** Ground installations allow the use of solar panels of various sizes, including large commercial modules with 72 cells or more. Rooftop systems are typically limited to 60-cell panels.





Figure: PV systems with ground installations, source:<https://naked solar.co.uk/solar-pv/solar-panel-mounting/>

Types of Ground-Mounted Solar Systems:

Standard Ground Mount:

- ✧ Utilizes multiple small anchors to support a racking table for solar panels.
- ✧ Anchoring methods include concrete piers, driven piers, helical piles, and concrete ballasts.
- ✧ Typically holds the solar array in a fixed position, with manual adjustment options becoming more popular.

Pole Mount:

- ✧ Involves digging a single deep hole to hold a large pole, connecting rails and mounting solar panels.
- ✧ Offers greater clearance from the ground, avoiding foliage and ground obstructions.



- ✧ Allows incorporation of single-axis or dual-axis tracking systems, enabling panels to follow the sun for increased energy production.
- ✧ Pole mounts with tracking systems may have a higher cost per watt compared to standard ground mounts.

Benefits:

- **Orientation Flexibility:** Ground-mounted systems allow optimal orientation for increased sunlight exposure.
- **Efficiency:** Improved efficiency due to increased air circulation beneath the panels, preventing overheating.
- **Maintenance Accessibility:** Easy access for maintenance tasks, simplifying upkeep and potential cost savings.

Considerations:

Land Usage: Requires open land, which may be a constraint for homeowners with limited available space.

Vulnerability to Damage: Exposed nature may lead to potential damage from wildlife or tampering.

Cost: Ground-mounted systems may incur higher upfront costs compared to rooftop installations.

In summary, ground-mounted solar panels offer advantages in terms of flexibility, efficiency, and maintenance accessibility, but considerations include land usage, vulnerability to damage, and potential cost differences.

Standard ground-mounted versus pole-mounted solar systems

	Standard ground-mounts	Pole-mounts
Cons	<ul style="list-style-type: none"> • Fixed angle limits how much sunlight panels can absorb • Standard mount systems don't work as well with areas prone to snow • More accessible, which means higher 	<ul style="list-style-type: none"> • Often cost more due to the tracking system and a complex setup • Tend to require more maintenance • Electricity needed to operate tracking system may not be worth the added



	Standard ground-mounts	Pole-mounts
Pros	<p>risk of damage due to wildlife or vandalism</p> <ul style="list-style-type: none"> • Typically less expensive than pole mounted systems • Easier to install and perform any maintenance on than pole-mounted systems • Can use alternative mounting if the ground is too hard for poles 	<p>benefits</p> <ul style="list-style-type: none"> • Tracking allows pole mounts to rotate, maximizing exposure • Tracking system tilts panels according to time of day and season • Takes up less surface area on your property



Figure: Ground-mounted photovoltaic systems offer a number of advantages over roof-mounted ones, source: <https://8billiontrees.com/solar-panels/solar-panel-racking/>

Ground mounted solar panel systems offer a number of advantages.

First, ground-mounted solar panels are very easy to install because they can be located on open ground. They don't require drilling into your roof, and the brackets used in standard ground-mount systems are lightweight and easy to remove. (If you choose pole mounting, they will usually be installed more securely.



Second, a ground-mount solar panel system can be more productive than a rooftop solar array panel. Because they are independent of your roof, ground-mounted solar panels are placed at the perfect angle to optimize energy production. This means you can generate more electricity than a comparable sized roof system and save more money in the long run.

Finally, ground mounted solar panels are very easy to clean and maintain. If you live in an area that gets a lot of snow in the winter, being able to easily clean the snow off your solar panels is a great convenience.

4.10. Types of Solar Trackers systems and their pros & cons.

Solar Trackers

Solar trackers are specialized solar mounts designed to enhance energy production by automatically adjusting the orientation of solar panels to follow the sun's position throughout the day. This continuous alignment ensures that the panels receive maximum sunlight exposure, optimizing energy capture. Unlike rooftop installations, solar trackers are typically ground-mounted due to their size and weight.





Figure: A PV tracker system, source:<https://www.greentechrenewables.com/article/pros-and-cons-solar-tracking>

Solar Trackers Overview:

Key Features:

- **Continuous Sun Tracking:** Solar trackers automatically move the solar panels to face the sun directly, maximizing sunlight exposure.
- **Ground-Mounted Installation:** Due to their size and weight, solar trackers are not commonly installed on rooftops but rather on the ground.

Applications:



- ❖ **Commercial/Industrial Businesses:** Solar trackers are commonly used in commercial and industrial settings to maximize energy conversion.
- ❖ **Residential Ground-Mounted Systems:** In cases where roofs are unsuitable or space is limited, solar trackers can be employed in residential ground-mounted systems.

Benefits:

- **Optimized Energy Capture:** Solar trackers narrow the angle of incidence, allowing panels to capture more energy by aligning with the sun throughout the day.
- **Performance Improvement:** Single-axis tracking systems can boost system performance by 25% to 35%, while dual-axis trackers provide an additional 5% to 10% improvement.
- **High-Precision Tracking:** Tracking systems use high-precision astronomical algorithms, GPS, and wireless communication for remote monitoring and control.

Considerations:

- ✓ **Installation Location:** Solar trackers are ground-mounted, requiring adequate space for installation.
- ✓ **Performance Gain:** While solar trackers enhance performance, their benefits need to be weighed against the additional cost and complexity of the system.

In summary, solar trackers are valuable tools for maximizing energy conversion in solar PV systems, particularly in commercial and industrial applications. Their continuous sun tracking capability ensures optimized energy capture, leading to improved overall system performance.

Key Features of the Tracking System

- Key Features of the Tracking System:
- **GPS Integration** and Astronomical Algorithms:
- GPS integrated with advanced astronomical algorithms for precise calculation of optimal solar altitude.
- **Automatic Tracking and Adjustment:**
- Intelligent programming allows the tracking system to automatically track and adjust based on solar position.
- **Wind, Rain, and Snow Modes:**
- Detection facilities enable manual or automatic adjustment to wind, rain, and snow modes for optimal performance.
- **Inverse Tracking Mode:**
- Introduction of an inverse tracking mode via software algorithms prevents shading by ensuring each module row tracks a reasonable solar altitude.

- Precision in Solar Incidence Angle:
- Astronomical algorithms ensure an angle error of $\pm 1^\circ$ within a 90° solar incidence angle.
- Fault Recognition and Self-Protection:
- Automatic fault recognition, self-protection, and alarm functions enhance system safety.
- Quadruple Overcurrent Protection:
- Fourfold overcurrent protection ensures the safety of the entire system.
- Multi-Point Drive Structure:
- The multi-point drive structure and rotary-drive support ensure overall system stability, reducing maintenance costs.
- Robust Hydraulic Damper System:
- Robust hydraulic damper system guarantees long-lasting durability and performance.
- Warranty and Lifecycle Testing:
- Industry-leading limited parts warranty and rigorous lifecycle testing for quality assurance.
- Weather Resistance:
- 120-mph wind rating, along with snow, wind, and cold modes, ensures the tracker's resilience to external influences.
- DC 24V Self-Powered System:
- The DC 24V self-powered system with a power storage unit supports minimal diverted power for motor operation. The annual power consumption per motor is only 10kWh.

In summary, the tracking system incorporates advanced features such as GPS integration, automatic adjustment modes, fault recognition, and robust design elements, ensuring optimal performance, durability, and safety in various environmental conditions. The self-powered system and comprehensive warranty further contribute to its reliability and efficiency.





Figure: Dual Axis Solar PV Tracker. Connections and Cabling. source: <https://eco-energ.co.uk/solar/solar-pv-tracker/>

EU Science Hub

Tracking PV systems

The European Union (EU) Science Hub provides a tool for estimating the energy production from various types of sun-tracking PV (photovoltaic) systems connected to the electricity grid. This tool is designed to help users calculate the potential energy output of sun-tracking PV systems based on characteristic angles defined by the user or calculated by PVGIS (Photovoltaic Geographical Information System) to maximize yearly energy production. The calculation takes into account solar radiation, temperature, wind speed, and the type of PV module used.

Here are some key features and information about the Tracking PV Systems tool:



Co-funded by
the European Union

Funded by the European Union. Views and opinions expressed are however those of the author(s) only and do not necessarily reflect those of the European Union or the European Education and Culture Executive Agency (EACEA). Neither the European Union nor EACEA can be held responsible for them.

Accessing the Tool:

- ◆ **PVGIS Interface:** The tool is accessible through the PVGIS interface under the "Tracking PV" tab.
- ◆ **Non-Interactive Service:** The tool can also be accessed through a non-interactive service using the /api/PVcalc endpoint.

Outputs:

- ✓ The output formats are similar to those for grid-connected PV systems.
- ✓ Monthly average values of PV system energy output and in-plane irradiation are provided per month and for the entire year.
- ✓ The calculations are based on a multi-year time series of solar radiation and other climatic parameters.
- ✓ Additional information about the calculation is included in the output.

Non-Interactive Interface:

- ✓ Users can choose to make calculations for fixed mounting systems, tracking systems, or both in the non-interactive interface.
- ✓ If the PVGIS tools are used, selecting the "Fixed grid-connected" tool provides output for fixed mounting systems, while the "Tracking grid-connected" tool provides output for tracking systems.

Overall, the tool is a valuable resource for assessing the energy potential of sun-tracking PV systems, taking into consideration various climatic parameters and system configurations.



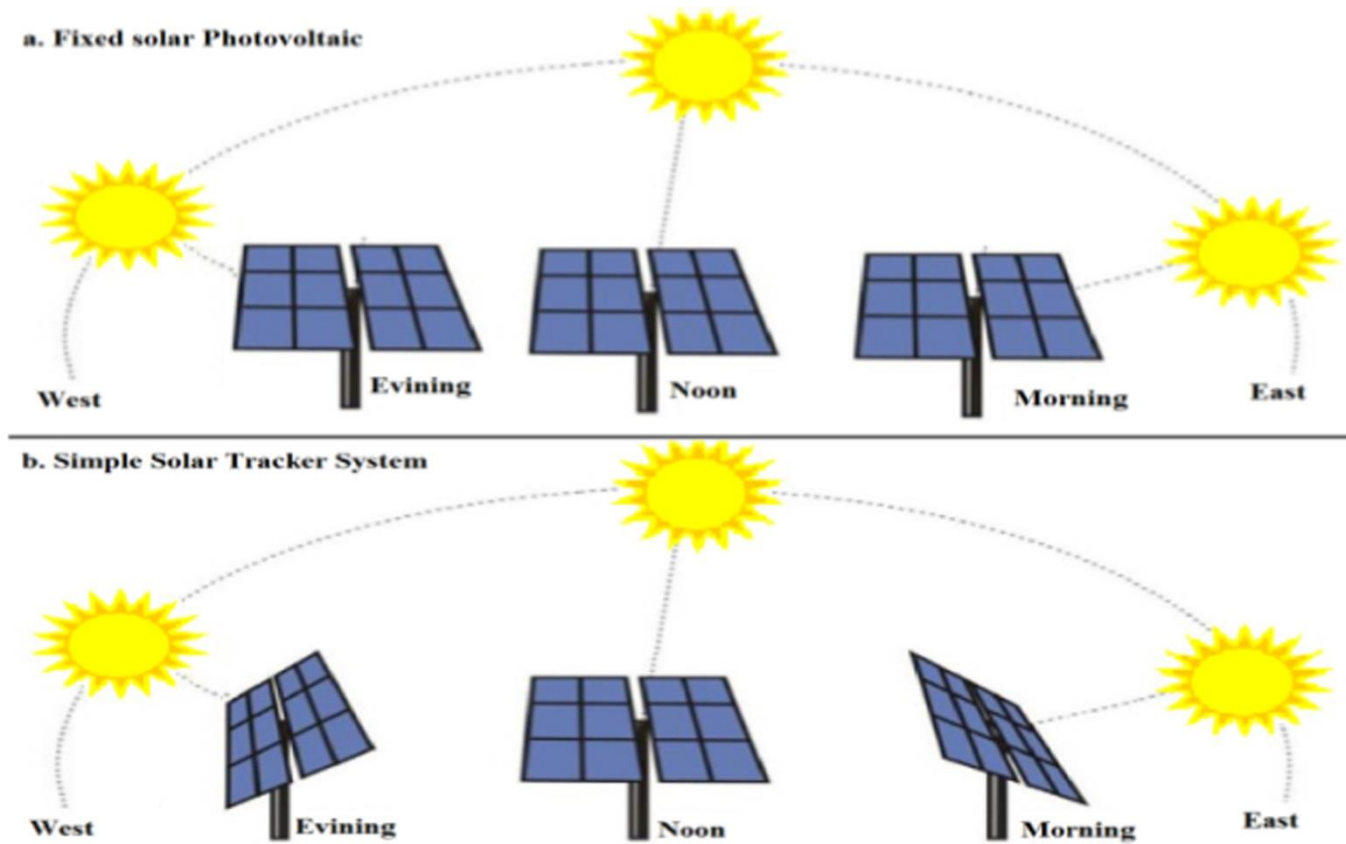

Figure: Fixed angle solar panel (a) and solar panels with a tracking system (b). source: <https://doi.org/10.1016/j.rser.2017.09.077>

Single-axis Solar Tracking Solutions

The single-axis solar tracker is a solar tracking solution designed to enhance energy yield per hectare by efficiently supporting a large number of PV modules with fewer columns. This solution is particularly well-suited for ground use, making it ideal for various-scale solar projects, including large, medium, and small-scale installations.

Key Features of the Single-Axis Solar Tracker (TR2):

Energy Efficiency

The tracker is designed to maximize energy production by allowing solar modules to follow the sun's path throughout the day, optimizing their exposure to sunlight.

Land Utilization



Compared to fixed solar systems, the single-axis tracker technology increases energy production by up to a third. This results in more efficient land use, enabling the generation of more power in a smaller space.

Ideal for Low-Latitude Areas

The tracker is primarily used in large solar power plants situated in low-latitude areas, where solar incidence is significant.

Suitable for Various Project Scales

Whether for large utility-scale solar power plants or smaller installations, the single-axis solar tracker provides a versatile solution.

Reduced Number of Columns

The design supports a large number of PV modules with fewer columns, contributing to a more streamlined and efficient system layout.

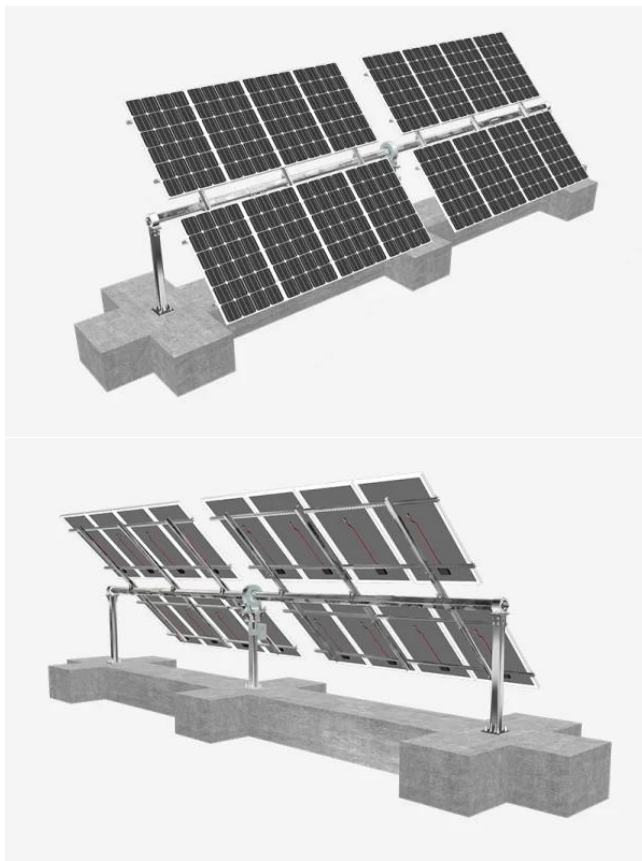

Figure: A single axis solar tracker, source: <https://www.mbtenergy.com/single-axis-solar-tracker>

In summary, the single-axis solar tracker offers an efficient and land-utilizing solution for solar projects, contributing to increased energy production and flexibility in system design.

Tilted Single Axis Solar Tracker

Tilted single-axis solar trackers are a type of solar tracking system with an axis of rotation situated between horizontal and vertical orientations. These trackers are designed to automatically adjust the tilt angle of solar modules to follow the sun's path, optimizing energy production. The tilt angles are typically limited to minimize wind resistance and the overall height of the system.

Features of MRac Tilted Single Axis Solar Tracker

1. **Application for Higher Latitudes** - The MRac tilted single-axis solar tracker is specifically designed for large-scale solar PV power plants located at latitudes higher than 40 degrees.
2. **Automatic Tracking System** - The tracker employs a single motor and control system to facilitate automatic tracking of the entire solar module array. This ensures that solar modules move in a symmetric cylindrical motion around the axis of rotation, following the sun's trajectory.
3. **Environmental Adaptability** - The system demonstrates good environmental adaptability, unaffected by rainy and cloudy weather conditions.
4. **Wide Range of Tracking Angle** - The tracking system provides a wide tracking angle range of up to +/-45 degrees, significantly improving power generation compared to fixed systems. This results in a 20% to 30% higher energy yield.
5. **GPS Equipped for Accuracy** - Equipped with GPS technology, the system ensures the accuracy of time, contributing to precise solar tracking.
6. **Weather Resistance** - The system is designed to withstand a wide range of temperatures, operating safely and stably between -40°C and 85°C.
7. **Electromagnetic Compatibility** - Excellent electromagnetic compatibility design enhances the stability and reliability of the system.



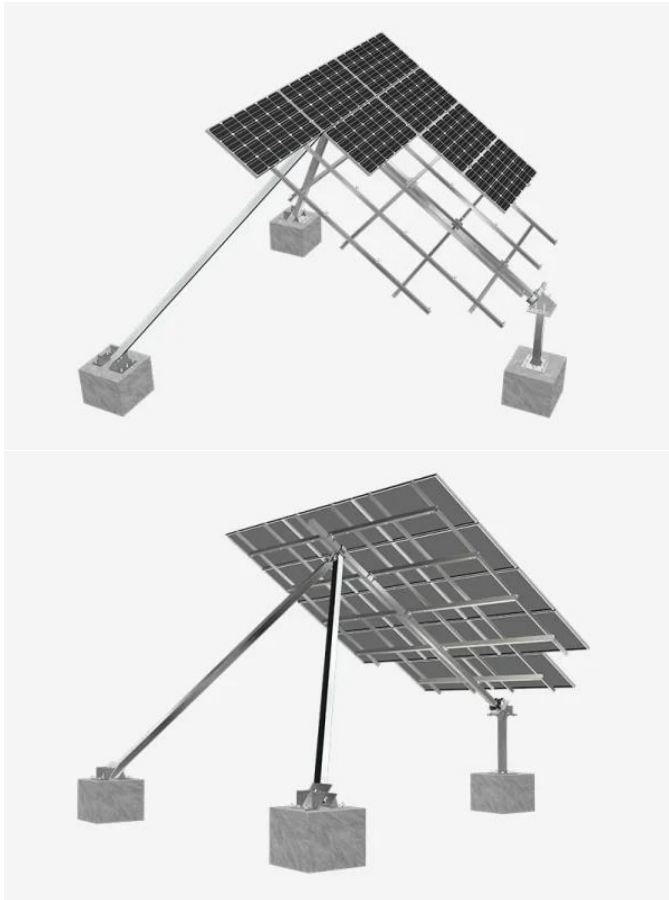

Figure: A tilted single axis

trackers, source: <https://www.mbtenergy.com/tilted-single-axis-solar-tracker>

Advantages:

Increased Energy Production: The tilted single-axis solar tracker optimizes energy production by adjusting the tilt angle of solar modules to follow the sun's path.

Adaptability to Various Conditions: The system is adaptable to different environmental conditions, ensuring reliable operation in a range of temperatures and weather scenarios.

Enhanced Efficiency: With a wide tracking angle range, the system achieves a higher energy yield compared to fixed systems.

In summary, the MRac tilted single-axis solar tracker is designed for efficiency and adaptability, providing automatic solar tracking to maximize energy production in large-scale solar power plants.

Dual Axis Solar PV Tracker.



Dual-axis solar PV trackers are advanced tracking systems designed to align solar panels with the optimum angle to the sun throughout the day. These trackers utilize precise astronomical controls to achieve optimal solar alignment, ensuring maximum energy production. The following is an overview of the dual-axis solar PV tracker with a focus on its technical features and advantages.

Technical Features

Biaxial Tracking System: The tracker employs a biaxial (dual-axis) tracking system for photovoltaic installations. This allows for precise adjustments in both horizontal and vertical axes to follow the sun's path.

1. **Astronomical Control** -The tracker features an astronomical control system based on local coordinates. This enables accurate and automated adjustments to the solar panels for optimal alignment with the sun.
2. **Centralized Monitoring** - The system can be monitored centrally via the Internet, providing real-time information on its performance and energy production.
3. **Comprehensive Safety Concept** -The dual-axis solar PV tracker incorporates a comprehensive safety concept to safeguard its operation and prevent potential risks.
4. **Building Integration Feasible** - The design of the tracker allows for feasible integration into buildings, offering flexibility in installation.
5. **Additional Yield** - Compared to fixed-mount installations, the dual-axis tracker can provide an additional yield of up to 45%, significantly increasing energy production.
6. **Track-Back Function** - The system includes a track-back function designed to prevent cross-shading, ensuring efficient solar tracking.
7. **20-Year Warranty** - The tracker is designed for long-term performance, and it comes with a 20-year warranty, subject to the terms of the service agreement.
8. **Suitable for All Panel Brands** - The dual-axis tracker is compatible with panels from various brands, offering versatility in system integration.



Figure: Performance of a sonnen_system tracking unit for 24 hrs vs. performance history of a fixed-mount photovoltaic system of the same system size, source: <https://eco-energ.co.uk/solar/solar-pv-tracker/>

Advantages:

- ◆ **Optimized Structure** - The tracker features a robust and optimized structure that provides stability and support throughout its operational lifetime.
- ◆ **High Energy Yield** - With precise solar tracking in both axes, the system can achieve a higher energy yield (up to 45% more) compared to fixed-mount installations.
- ◆ **Long Operational Life** -The sonnen_system is designed to operate for over 20 years, ensuring a durable and reliable tracking solution.
- ◆ **Building Integration** - The system is adaptable for integration into buildings, providing versatility in installation options.

In summary, the dual-axis solar PV tracker is a high-performance tracking solution with advanced features, providing increased energy production, durability, and flexibility in installation. The use of astronomical controls and safety features makes it a reliable choice for optimizing solar panel alignment.

5. Safety rules for installation and operation. Basic steps for building a PV system.

Content

- 5.1 Safety regulation during the installation and maintenance of PV systems
 - 5.1.1. Risks associated with handling solar panels.
 - 5.1.2. Ladder Safety
 - 5.1.3. Trips and Falls – Risks
 - 5.1.4. PV Electrical Safety
 - 5.1.5. Hazards and Mitigation in Installing Photovoltaic Systems
 - 5.1.5.1. Combustion and pollution
 - 5.1.5.2. Slips and falls.
 - 5.1.5.3. Collapse
 - 5.1.5.4. Risks from electric arcing and improper electrical grounding
 - 5.1.5.5. Electrical shock
 - 5.1.6. Santon Firefighter safety switch (DFS)
 - 5.1.7. Personal Protective Equipment for PV Workers
- 5.2. Basic stages of building a small photovoltaic system
 - 5.2.1. Introduction
 - 5.2.2. Selection of location, direction and angle for solar installation - First stage
 - 5.2.3. Design and purchase of the main components of the photovoltaic system - Second stage
 - 5.2.4. Install Solar Panels on Roof - Third stage.
 - 5.2.5. Earthing & Lightning Protection - Fourth stage
 - 5.2.6. Commissioning of Solar System - Stage Five



5.1. Safety regulation during the installation and maintenance of PV systems.

5.1.1 Risks associated with handling solar panels

According to labor statistics, jobs for solar photovoltaic (PV) installers are expected to grow by 40-50% between 2019 and 2029, growing at a much higher rate than the average for all occupations, making them the third most fast growing profession.

Between 2011 and 2019, 650 solar PV installers were injured on the job.



Figure: Installers of PV Systems and safety risks,

source: <https://www.thehartford.com/insights/home-workplace-safety/solar-energy-benefits-safety-risks>

Therefore, it is very important that installers get knowledge and skills about the safety rules when working with solar panels. Workers in the solar industry face various risks, like:

- ✓ Falls from high rooftops
- ✓ Electrocution or other electric hazards
- ✓ Repetitive stress injuries



- ✓ Cuts or sprains

In addition, workers likely face risks from the construction industry – one of the most dangerous industries.

Due to the risks faced by businesses and workers, Occupational Safety and Health Agencies in a number of European countries require employers to provide mandatory safety and protection training for their employees. Such training begins with a due diligence on the construction site. Because every workplace is unique and carries different risks. It is essential that the installer visits the site, identifies safety risks and develops specific plans to address them. This may include:

- ✓ Equipment for safe lifting and handling of solar panels
- ✓ Type and size of ladders and scaffolding
- ✓ Fall protection when working on the roof
- ✓ Personal protective equipment (PPE) for workers, etc.

Safety issues are common for solar installations, but proactively putting preventive measures in place can help mitigate on-the-job injuries.

Risks associated with handling solar panels



Figure: Safety information label for installation of PV systems

Solar panels are heavy and awkward to lift and carry. Loading and unloading panels from trucks and onto roofs can cause:

- Strains;
- Sprains;
- Muscle pulls;
- Back injuries.



Solar panels also heat up quickly when exposed to sunlight. So if PPE is not worn or the panels are not handled properly, they can cause burns.



Figure: Safety when handling a **PV** panel, source: energysage.com/solar-panel-safety-need-know/

When it comes to solar panel safety, workers can reduce the risks of injury by:

- Having two people lift panels with the correct lifting technique;
- Using mobile carts or forklifts to transport panels onto and around the work site;
- Never climbing ladders while carrying solar panels;
- Using properly inspected cranes, hoists or ladder-based winch systems to get panels onto roofs;
- Covering uncovered panels with an opaque sheet to prevent heat buildup;
- Always wearing gloves when handling panels.



5.1.2. Ladder Safety



Solar installations often involve working on roofs from ladders. So, having the right type of ladder and using it correctly is essential to worker safety.

Select the ladder that best suits the need for access. This can include a stepladder, straight ladder or extension ladder. Be aware that straight or extension ladders should extend a minimum of 1 m above the rung that the worker will stand upon.

Choose the right ladder material. Aluminum and metal ladders are commonly used, but they're a hazard near power lines or electrical work. Instead, a fiberglass ladder with non-conductive side rails may be a better option near power sources.

Place the ladder on dry, level ground. Make sure the feet of the ladder are away from walkways and doorways and at least 3 m from power lines. Secure the ladder to the ground or rooftop for added stability.

The risks include:

- ✓ Fractures or sprains;
- ✓ Puncture injuries;
- ✓ Back, neck, and head trauma;
- ✓ Cuts and bruises.



5.1.3. Trips and Falls - Risks



Rooftop solar installations can pose a higher fall risk because there's less work space as more panels get installed.

In construction, falls accounted for nearly 39.2% of fatalities in year. The most common height of fatal construction falls was from more than 10 m (107 deaths of 325 fatal falls).

The risks include:

- Broken, Fractured, or Shattered Bones;
- Severe Back, Neck, and Head Trauma;
- Internal Injuries;
- Puncture Injuries.



Workers who are six feet or more above a lower level need to have some protection:

- Guards around edges;
- Covers over holes;
- Safety nets;
- Personal fall arrest systems.

When using a personal fall arrest system, the harness must be rated for at least 5,000 pounds (22.2 kN), and the anchoring system must be rated for at least 5,000 pounds (22.2 kN) per attached worker.



5.1.4. PV Electrical Safety



Solar systems include many components that conduct electricity. Electricity comes from two sources: the utility company and the solar array (i.e. the sun). Even when a building's main breaker is shut off, the PV system will continue to produce power. Risks include:

- Thermal burns;
- Muscle, nerve, and tissue damage;
- Falls from a surprise shock;
- Death.

Some of the ways you can keep workers safe include:

- Treating wiring coming from a solar PV system with the same caution as a utility power line. That means assume all wires are live.
- Using a meter or circuit test device to ensure circuits are de-energized before working on them.
- Locking out power on systems that can be locked out. Tag all circuits you're working on at points where that equipment or circuit can be energized.
- Never disconnecting PV module connectors or other associated PV wiring when it's under load.
- Check your equipment to ensure it is in safe working order;
- Work at a safe distance from power lines;



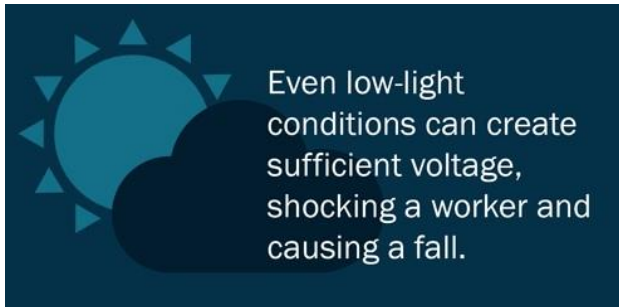

- Cover the solar array with an opaque sheet to "shut out" the sunlight;
- Always test circuits to ensure they are de-energized before working on them;
- Use a clamp meter to check for hazardous energy before working on PV panels;
- Pay special attention around inverters. They can maintain a powerful charge even when the power is off;
- Wear appropriate electrical safety PPE

PV Installation Electrical Safety

- Locate all overhead power lines
- Consider all overhead lines to be live, energized, and dangerous
- Keep yourself and equipment 3m away from all overhead power lines
- Carry ladders and other equipment horizontally when on the ground to avoid overhead power lines



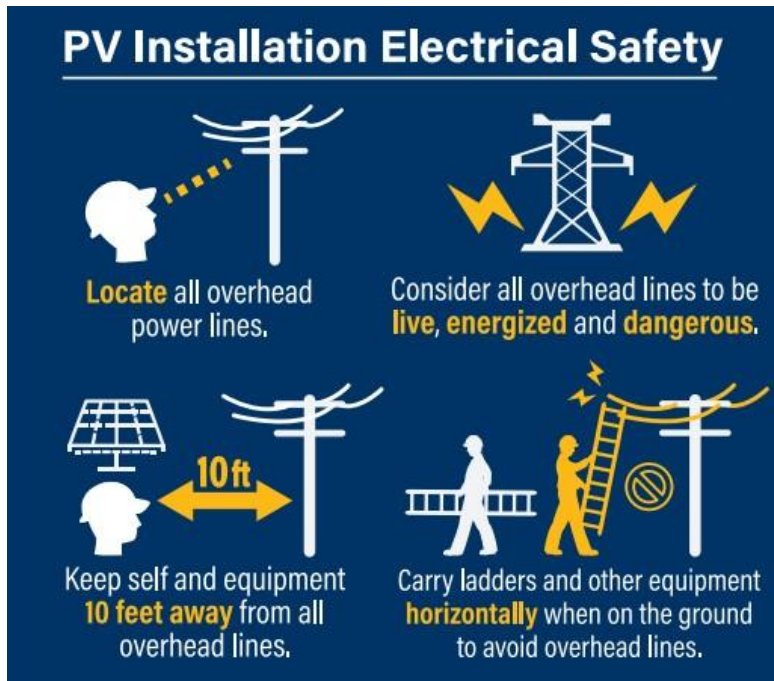

PV Panel Electrical Safety

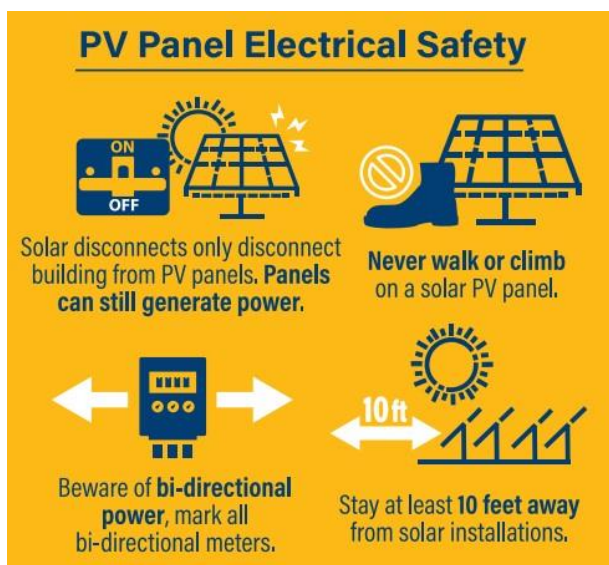

- Solar disconnects only disconnect buildings from PV panels. Panels can still generate power
- Never walk or climb on a solar PV panel
- Beware of bi-directional power, mark all bi-directional meters
- Stay at least 10 feet away from solar installations



In Case of Emergency Involving Solar Panels

- Call 112 and notify first responders that PVs are involved
- If possible, turn off the AC side of solar panels. Solar panels may still generate DC power
- Remind first responders of PV systems

In Case of Emergency Involving Solar Panels

 <p>Call 112 and notify first responders that PV are involved.</p>	 <p>If possible, turn off AC side of solar panels. Solar panels may still generate DC power.</p>	 <p>Remind first responders of the PV system.</p>
--	---	--

5.1.5. Hazards and mitigation in photovoltaic systems

Photovoltaic systems are extremely safe under normal operating conditions if installed and maintained by professionals in accordance with electrical regulations and guidelines. However, with the increasing prevalence of various photovoltaic systems operating both on the ground, on roofs and even integrated into buildings, there is a certain risk of possible fire.

Over the past 15 years, 400 fires involving photovoltaic systems have been reported in Germany. In 180 cases, a photovoltaic component was the source of the fire. To emphasize the safety of photovoltaic systems, it should be mentioned that these 180 cases represent less than 0.1% of all fires in Germany during this period.





Figure: Solar installation under fire, source: <https://www.pv-magazine.com/2021/07/02/australias-unsafe-solar-installation-standards-under-fire/>

The placement of the PV systems on the roof is outside the fixed fire protection and detection functions of the building. This can mean delayed fire detection and a lack of fixed fire protection. In addition, the flammable characteristics of the module and other components add fuel to sustain a fire. When a fire develops under the PV modules, the modules will reflect the heat from the fire back down to the roof, increasing the burn rate of conventional roofing materials. Roofing assemblies, traditionally considered "non-flammable", become flammable or quickly combustible.

With these types of systems, the fire department is cautious because the energy generated by the panels cannot be turned off. Even at night, fire department scene lighting has been determined to be sufficient to generate an electric shock hazard. Defensive firefighting measures – spraying water from a distance – were found to have a reduced impact as the PV panels obscured and protected the fire from below.

5.1.5.1. Combustion and pollution

Potential hazards of PV systems and mitigation

Different components of a PV system are combustible due to their polymer content, for example: EVA encapsulation film and polymer back sheet in modules, polymers in string cables, junction boxes, and inverters. A research led by the German Federal Ministry of Economics and Technology identified that for a 9kWp system with 38 standard PV modules there is up to 60 kg of polymer material from modules alone. Polymers can produce an



elevated temperature comparable to the temperature of heating oil (PE: 46 MJ/kg > heating oil: 43 MJ/kg)

During and after the fire, the PV system can potentially produce emissions in liquid, solid or smoke forms. The general public is safe from dangerous concentrations due to the low amount of hazardous substances existing in PV systems. However, firefighters responding to the incident could be exposed with dangerous levels of metals such as lead (c-Si) or cadmium and selenium if thin-film modules are present in the system.



Figure: Roof fire, source: <https://www.firerescue1.com/electric-fire/articles/6-steps-to-safe-effective-solar-panel-ess-fire-attack-JtqmGDpotCQQrBfP/>

Mitigation:

- Firefighters must be informed about the existence of the **PV** modules as well as their location and type in order to plan their actions accordingly and safely.
- Firefighters must use masks to protect themselves from harmful and potentially toxic gas.



- Debris from a damaged PV site requires professional disposal.

5.1.5.2. Slips and falls

Space limitation on the roof with PV system reduces the accessibility and may cause slips and/or falls.

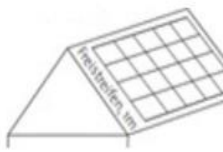

Create access to the roof truss over a free strip

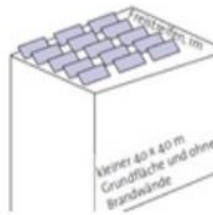

Create access to the roof truss for smaller flat roofs without via free strip on the longer side

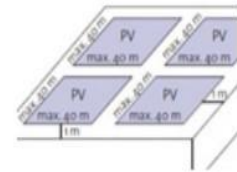

For large roof access should be given for every fire section (usually 40m x 40m) around the generators. Width should not be less than 1m

**Inclined roof
roof**

**Flat roof without any ingress routes such as
windows or skylight**

Large flat

Mitigation:

- Preserve walkways with a certain width and setbacks from roof boundaries.
- Label DC cables and keep an updated map of DC cable layout.

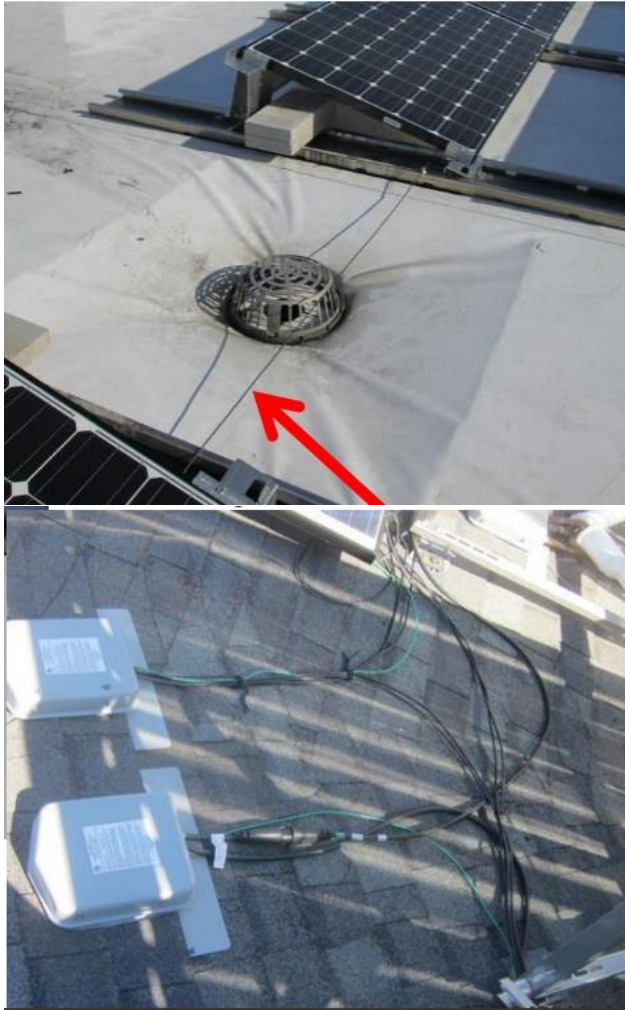

5.1.5.3. Collapse

PV equipment adds to the load on the roof, which can lead to a potential roof collapse. This hazard grows if the support beams are weakened during a fire. The modules could also fall during the fire, endangering both inhabitants and first responders.

Mitigation:

- Be careful during the designing process and consult with the structural engineer if necessary.
- Always inform firefighters of the presence of a **PV** system on the roof.



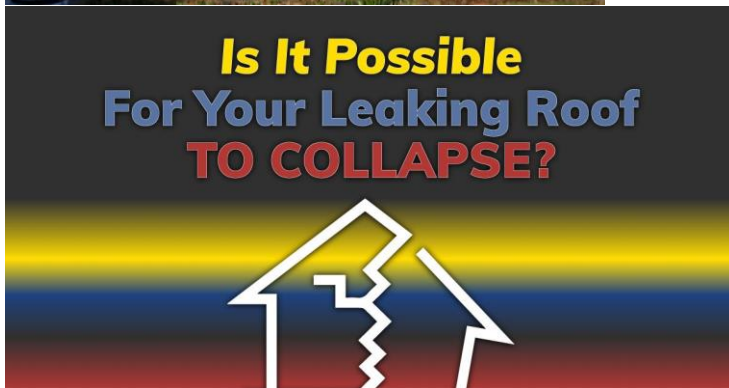

You can prevent roof collapse as soon as you notice a minor leak. Don't ignore the leak until it grows larger. By that point, your roof deck may already be rotten and weak, not to mention all of the mold growing in your home.

Roof leaks are not always as obvious as you'd think. Keep an eye out for the following signs of a leak:

- Muggy, humid air in the attic
- Discolored spots on your ceiling or at the top of a wall
- Dark spots on your attic ceiling
- Missing or torn shingles

5.1.5.4. Arc or ground fault

PV systems have a high DC voltage which potentially creates a non-self-extinguish arc in case of a fault occurrence. The arc will continue until the voltage is turned off or the distance between arc contacts is increased.

The result for these arcs could be the poorly soldered cell connectors or soldering between cell connectors and the busbars inside the module.





Figure: Fire caused by DC arcing

faults, source: <https://www.acsolarwarehouse.com/news/solar-fires-dc-arc-faults-on-solar-systems/>

The temperature of an electrical arc depends on a number of factors, such as the level of current flow, but on a typical PV system, it is easily hot enough to melt glass, copper and aluminum, and to initiate the combustion of surrounding materials.

DC arc faults occur on the DC cabling of PV solar systems.

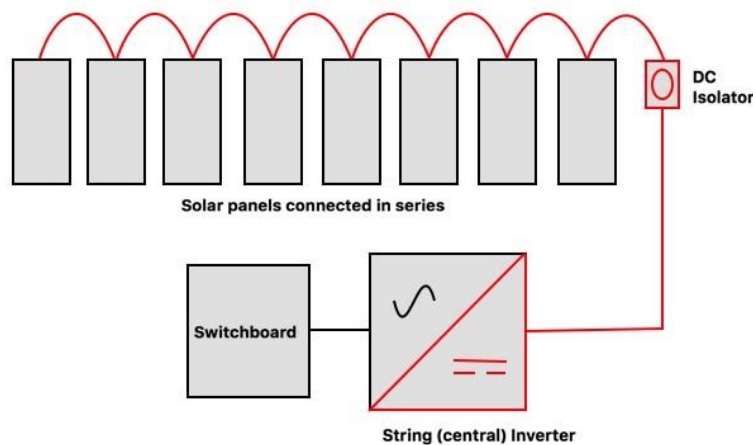

Figure: Schematic string inverter solar system with unprotected DC cabling. Cabling, joints and electrical equipment exposed to DC arc faults are shown in red

Faults can occur anywhere on the DC cabling that runs from the solar modules on the roof to the string inverter which is usually installed adjacent to the main switchboard. There are approximately 26 connections in the DC circuit of a small domestic solar system (2kW) which are effected on site by the solar installer and approximately 50 connections on a 5kW

system. All of these connections undertaken by the solar installer is a potential point of failure.

There are also additional connections inside the solar modules, DC isolators and the string inverter which are potential points of failure.

5.1.5.4. Arc or ground fault

Low-quality junction boxes with unstable cable connections and unsealed boxes can lead to corrosion, poor heat dissipation, low-quality bypass diodes also potentially resulting in an arc fault.



Figure: Poor quality junction boxes with unstable cable connections are potential points of arcing fault occurrence.

Another risk can arise when cross-mating connectors from two different manufacturers. The electrical transition resistance may significantly increase, resulting in intense heating of the affected component.



Figure: A cross-mating connectors from two different manufacturers potential points of arcing fault occurrence.

Mitigation:

- Choose only high-quality **PV** system components such as **PV** modules, cables, inverters.
- Do not cross-mate connectors from different manufacturers.

5.1.5.5. Electrical shock:

PV modules keep producing power as long as they are exposed to a sufficiently powerful light source. Even artificial light sources from halogen lamps can produce enough power to energize PV systems to a dangerous level. The same threat can come from light emanating from a nearby fire.



Figure: Lightning can produce enough power to power photovoltaic systems to dangerous levels, source: <https://www.solar-electric.com/learning-center/solar-system-lightning-protection.html/>

Another potential risk is if a firefighter must open the roof in order to access the PV system. This means cutting through live conductors, an action that almost always creates an arc and can constitute a significant and dangerous shock hazard.

Even damaged modules can still produce power which may harm firefighters and first responders during a containment operation. A test shows that even after damage caused by heat or fire, 60% of the modules from the test site can still operate at full power.

Mitigation:

- De-energize the PV system.
- Firefighters must be equipped with a self-contained breathing apparatus.
- Implement Rapid Shutdown solutions to eliminate firefighter exposure to the risk of direct contact with live DC cable.

5.1.6. Santon Firefighter safety switch (DFS)

In Germany, the VDE-AR-E 2100-712 requires no more than 120 V throughout the PV array after shutdown.

The device (firefighter safety switch) can be installed near PV strings. In the case of a fire, when the firefighter switches off the AC circuit, the switch directly disconnects the DC current in close proximity to the solar modules which makes the place much safer for firefighters. The DFS will behave the same way if the temperature rises above 100°C.



When AC power comes back on then the DFS device automatically switches on the DC power.

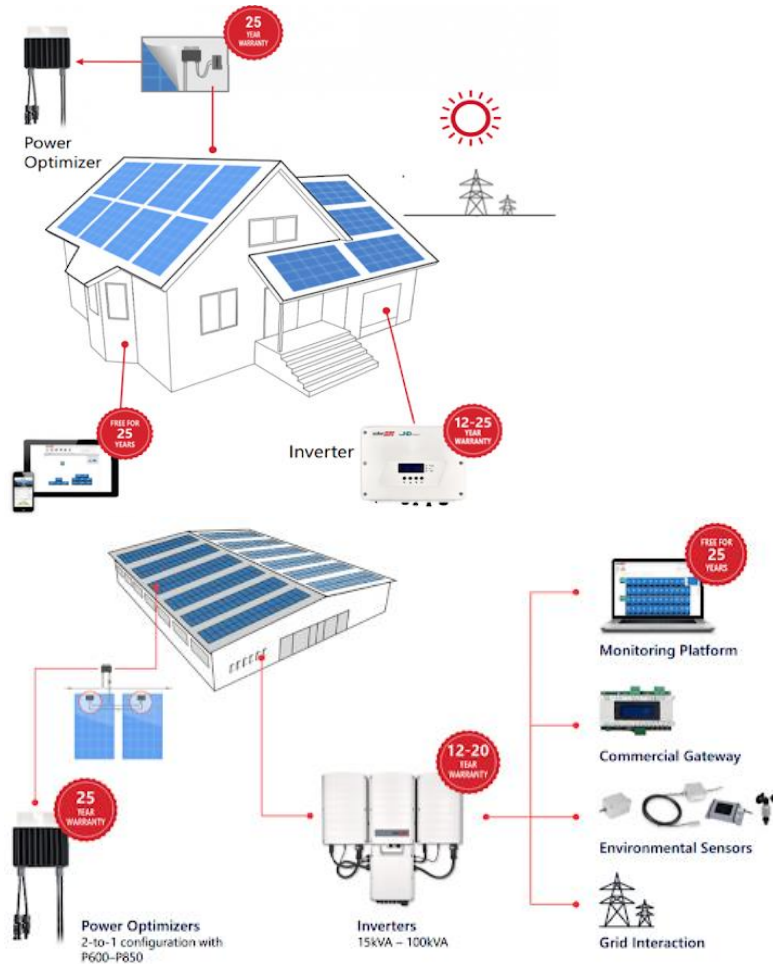

Figure: Possible schemes using the fireman's safety switch, source: <https://solarity.eu/blog/fire-hazards-and-mitigation-in-photovoltaic-systems/>

If one of the following methods is applied (see the above figure), the string voltage will be reduced to an equal number of modules per string (if there are 30 modules in the string, then within 30 seconds the string voltage is 30 V):

- The AC breaker on the inverter is turned off, or the AC to the inverter is turned off by some other method (intentional or as a result of a malfunction).
- The ON/OFF switch of the inverter is off.
- DC switch is off (applicable only to inverters with DC protection device).

5.1.7. Personal Protective Equipment for PV Workers



Figure: The installer and his personal protective equipment.

Personal protective equipment (PPE) is essential during every solar installation. Employers have to assess workplaces for hazards and make sure they provide workers with the necessary PPE for their safety. This can include:

- Hard hats;
- Gloves;
- Steel-toed shoes with rubber soles;
- Eye protection, like glasses or goggles;
- Vests;
- Harnesses.

Make sure employees know how to use the PPE, as well as how to maintain it so it is kept in safe and reliable condition. Workers should know the process to request replacement PPE if it's necessary.

Personal protective equipment, or PPE, is designed to protect workers from serious workplace injuries or illnesses resulting from contact with workplace hazards of any variety.

In general, employers are responsible for:

- Performing a “hazard assessment” of the workplace to identify and control physical and health hazards.;
- Identifying and providing appropriate PPE for employees;
- Training employees in the use and care of the PPE;
- Maintaining PPE, including replacing worn or damaged PPE;



- Periodically reviewing, updating and evaluating the effectiveness of the PPE program.
- **In general, employees should:**
 - Properly wear PPE;
 - Attend training sessions on PPE;
 - Care for, clean and maintain PPE;
 - Inform a supervisor of the need to repair or replace PPE.

5.2. Basic stages of building a small photovoltaic system

5.2.1. Introduction

As we already understood from the previous lectures, solar panels are a universal source of energy. The size of a photovoltaic installation can vary from just 3 to 4 panels mounted on the roof of an individual home to millions of panels installed for a utility-scale power plant. The adoption of rooftop solar installations by individual families for their homes is growing rapidly within the borders of the European Union and globally.

A some easy steps/etaps to install a photovoltaic system.



Figure: A installation of a photovoltaic system. source: <https://www.philergy.com/post/is-my-roof-compatible-with-solar-panels-mounting-solutions-on-various-roof-materials-philergy>

This point we will look at the most important stages of installing a PV installation as well as the factors to consider and the best practices to follow to ensure:

- safe and reliable installation with minimal system downtime
- maximum electricity generation for the installation site
- long life with minimal maintenance and component replacement
- electrical safety
- minimized risk of damage during cyclones and high wind conditions

5.2.2. Selection of location, direction and angle for solar installation -

First stage:

Selection of location, direction and angle for solar installation The most important factor in choosing a place to install a solar panel is the presence of an area without shade. For a typical roof installation of an individual home, we are faced with a number of shadow-casting objects such as nearby trees, neighboring houses or buildings, mobile towers, water tanks, stairwells or muti, satellite dishes, etc. Although an area may feel shadow-free to the naked eye, it is not possible to say with certainty that there will be no shadows at all times of the day and throughout the year.

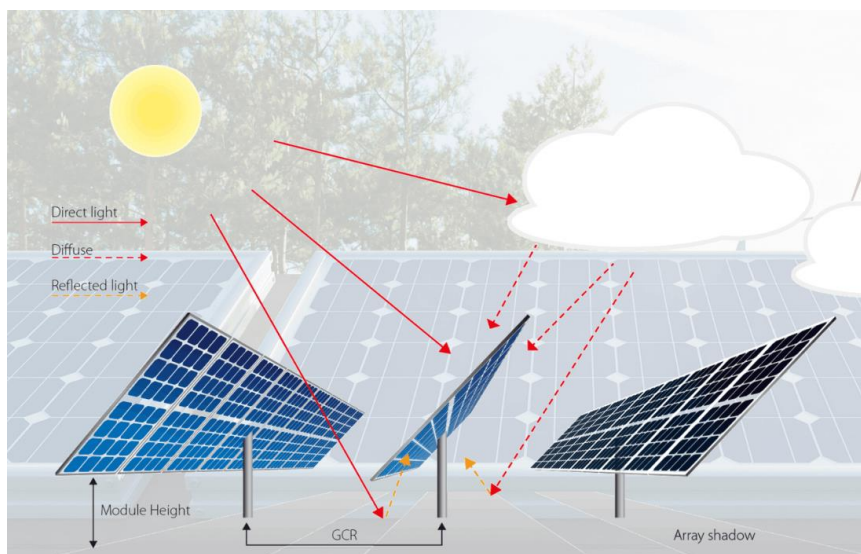

Figure: Site selection, assessment of solar radiation yield, orientation, and shading.

The solution to this question is achieved with an analysis that is carried out with the help of specialized software such as "Google SketchUp" (and similar on the Internet). With their help, an analysis can be made and it can be guaranteed that the solar panels will remain without shade from 9 am to 4 pm throughout the year.

Apart from location of solar panels, it is also important to choose appropriate locations for other components such as inverter, lightning arrester & earthing. Solar inverters should be installed in an indoor location or in shade from direct sunlight. They must be at eye level (around 4 to 5 ft height from ground) for ease of monitoring & maintenance.

As Europe is in the northern hemisphere, the direction of the solar panels should be south to maximize the solar radiation received. East or west direction can also be considered if south is not possible due to limitations in available area. For example, for an east- or west-facing installation, the annual energy generation for a system is approximately 4 to 5% less than a south-facing system. The north direction of the solar panels should be avoided as it will cause a significant reduction in energy generation.



Figure: The continent Europa, source: <https://en.wikipedia.org/wiki/Europe>

The tilt or tilt angle to be provided to the solar panels should ideally be equal to the latitude of the location to maximize power generation. This varies from 20 degrees in South Europe



to 50 degrees in North Europe.

It is good at this point to clarify the question of how you can calculate the correct angle for the inclination of the solar panels. In addition to using specialized solar panel angle calculators from the Internet, you can also do the calculations yourself. Calculating the angle of inclination in summer is very different from calculating it in winter.

There are two main methods for such calculations.

The first approach to calculating the correct angle for solar panels is by subtracting 15 degrees from the latitude of the solar system. This is a great option for hot summer days. For winter days, add 15 degrees to the latitude.

The second approach involves multiplying the latitude of the location by 0.9 and then subtracting 23.5 degrees from the result. This calculation is again for the summer season. Repeat all steps for the winter season, then add 29 degrees to the result.

5.2.3. Design and purchase of the main components of the photovoltaic system -

Second stage

We will not dwell on the activity of designing the system, as this is beyond the scope of this study material and requires other competencies.

The following components constitute a typical rooftop solar system installed on an individual home:



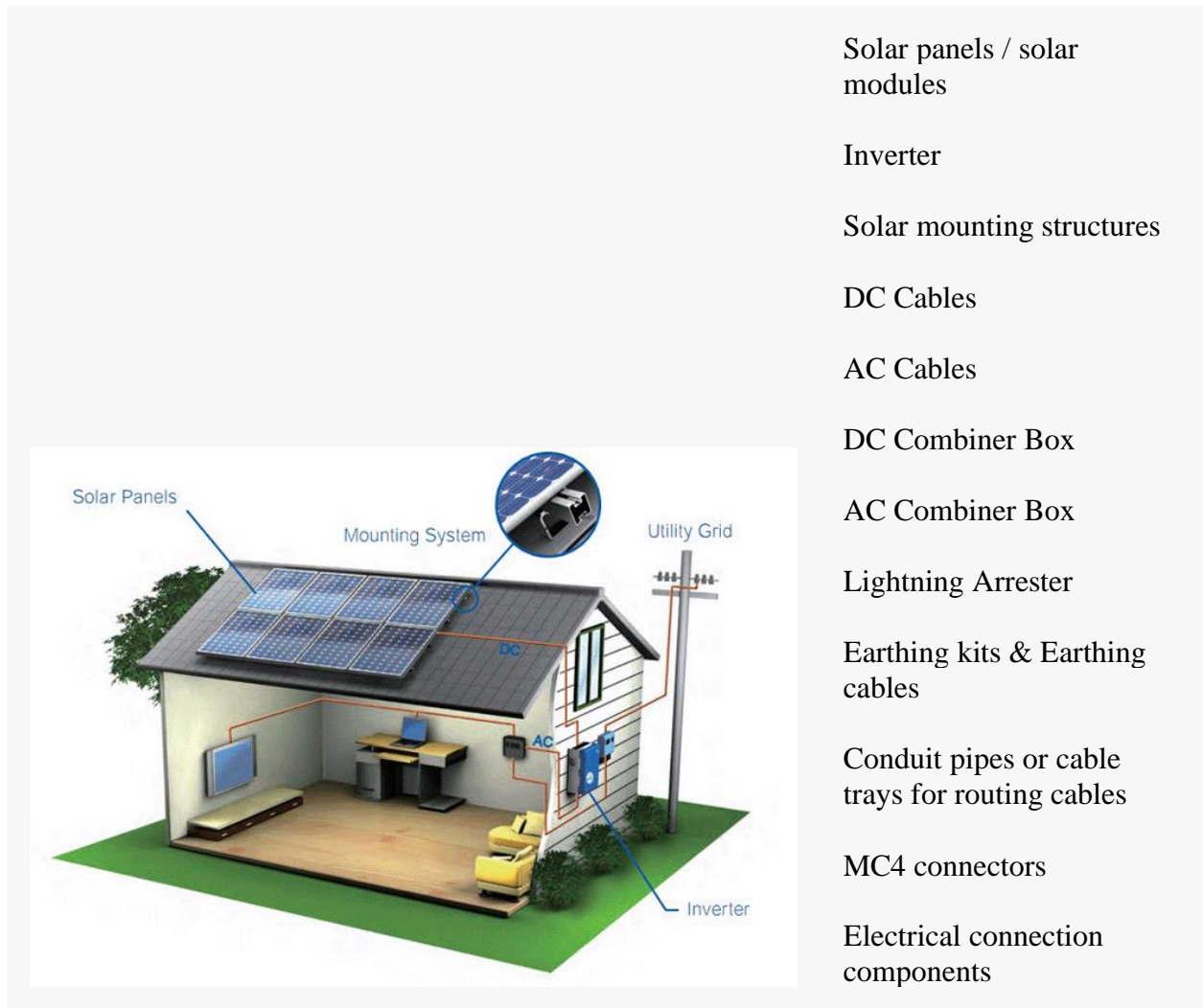

Figure: Components of solar system, source: <https://www.gogreensolar.com/pages/solar-components-101>

The above components constitute a grid-connected solar system, where solar power is generated only when the system is connected to the electricity grid. These are the most common type of system installed on residential rooftops in cities & towns where grid shutdown is rare. Off-grid or hybrid systems can generate & supply power even when not connected to the electricity grid. Here batteries are also required to store the electricity generated. These are used in rural areas not connected to electricity grid.

As can be seen above, solar panels are only one of the components of the entire solar system. For a well-engineered solar panel installation, it is important to focus not only on the selection of solar panel technology & make, but also:

- Selection of right specifications & quality of all other components
- Engaging professional teams trained in following delivery, handling & installation Standard Operating Procedures of all components
- Use of specialized purpose-built tools for installation

5.2.4. Install Solar Panels On Roof -

Third stage

The first component installed before the solar panels are the solar mounting structures. Depending on the type of roof, various installation structures are offered - for installation of a metal canopy, on a SKTD terrace, on tiles, etc. Increasing the height of the prefab structures of an RCC terrace can reduce the shadow cast on the solar panels and also allow the terrace below the panels to be used for other purposes.





Figure: Depending on the type of roof, different mounting structures are available

The mounting structures are the most critical component to ensure that the solar panel installation is safe during high winds and cyclones. They must be evaluated with specialized software for the wind loads applicable at the installation site, using the parameters defined by the specific national standard.

It is also important to evaluate the method used to fix the structures to the roof and ensure that it does not result in water leaking through holes drilled in the roof. Another factor to consider is the material used and the coating provided on the structures. Steel and aluminum are the most commonly used materials. The steel must be galvanized to protect against corrosion. Welding structural components in place should be avoided as it removes the protective coating and accelerates rusting.

Solar panels are mounted on mounting structures using brackets or nut and bolt fasteners. It is extremely important to ensure that the installation of the solar panel is carried out in accordance with the manufacturer's installation manual. Any deviations from the instructions may void the manufacturer's warranty for the panels. Proper handling and lifting of the panels according to the manufacturer's instructions is also very important to ensure that there is no visible damage to the silicon cells inside the panel. Only trained and experienced professional teams should be engaged for this activity. Specialized tools such as a torque wrench should be used to assemble mounting structures and solar panels to ensure all connections are fully tightened.

5.2.4. Inverter Installation & Electrical Wiring

Third stage

Solar panels are connected in series by connecting the positive cable of one panel to the negative cable of the next panel and so on. This is called a string, whose output voltage is the sum of the voltage of all panels connected in series. Depending on the project and inverter capacity, multiple such strings are created and are connected in parallel.

Each string is connected to a DC Combiner Box, which provides electrical surge protection & DC isolation, and then to the inverter using solar-grade DC cables. All DC cable connections are done using MC4 connectors, which should be crimped on the cables using a specialized MC4 crimping tool only. As string voltages are in the range of 1000 V DC, DC wiring is a potential source of electrical shock and short circuit if the connections are loose or done using improper tools.





Figure: Inverters are converters of direct current into alternating current, but at the same time they are also the control brain of the photovoltaic system, source: <https://www.gogreensolar.com/pages/solar-components-101>

Inverters are the brains of a solar power system. They are responsible for converting DC power (from your panels) into AC power (the format that is usable by your household appliances). They also route the flow of electricity between system components, and most provide a monitoring solution to track your system's performance.

There are a few types of inverters to choose from:

- String inverters
- String inverters with PV optimizers
- Microinverters
- Storage-ready inverters

5.2.4. Inverter Installation & Electrical Wiring-

Third stage

The inverter output is connected to the electricity grid at the energy meter via an AC Combiner Box, which provides electrical surge protection & AC isolation. Electrical lugs of appropriate size as per the cable size must be used for AC cable connections with electrical termination standard practices followed.

All cables are routed inside PVC or HDPE conduit pipes for protection. Cable trays may be used in case of a large number of DC strings or large size of AC cables. Cable routing in pipes or trays requires very precise alignment, which has a big impact on the overall aesthetics of the installation.





Figure: Cables in PVC or HDPE conduits provide protection. says a great influence on the overall aesthetics of the installation, source: <https://www.solarsquare.in/blog/how-to-install-solar-panels/>

For a residential solar system, the energy meter is replaced by a bi-directional net meter. The net meter measures both the no. of units of electricity imported from the grid as well as exported to the grid and the consumer is charged for the net units consumed (import units minus export units).

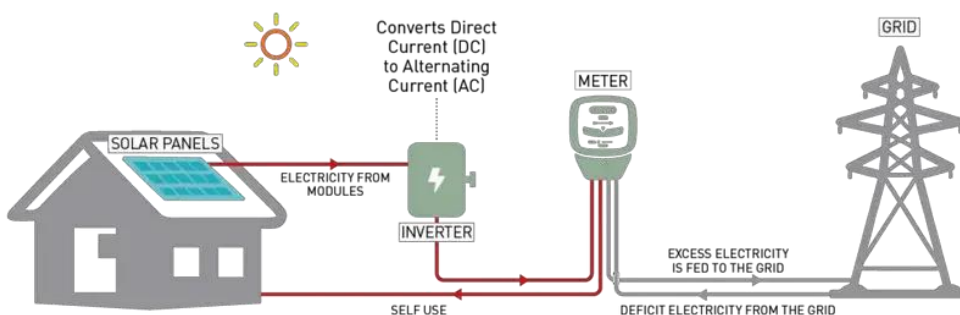

Figure: Two-way electrometers are a mandatory new component in grid-connected photovoltaic systems, source: https://letsaveelectricity.com/what-is-solar-net-metering-system/?utm_content=cmp-true

5.2.5. Earthing & Lightning Protection

Fourth stage

Earthing is provided to the DC components (solar panels & DC combiner box) and AC components (inverter & AC combiner box) using separate earthing cables. The earthing grid is created using maintenance-free earthing kits consisting of earthing rods & chemical compounds. Earthing should be provided preferably in soft soil rather than concrete or tiled area, with a spacing of 2 to 3m between each earthing rod. It should be as close to the solar installation as possible to reduce the length of cables used.

A Franklin rod type lightning arrester is installed near the solar panels at a height at least 1m above the panels. They should not cast a shadow on the panels at any time of the day. It is connected to the earthing grid using an earthing cable sized 16 sq mm or higher.



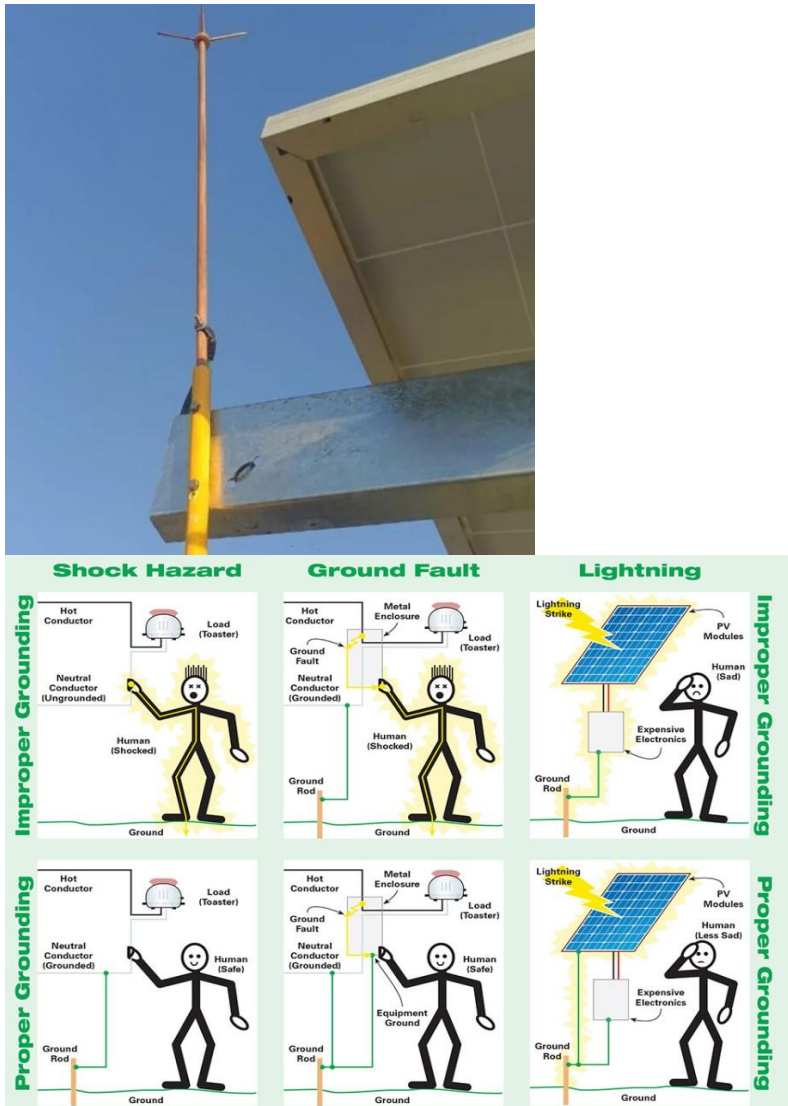

Figure: Ensuring grounding and reliable lightning protection of all system components is an important stage of its operation. source: <https://www.solarsquare.in/blog/how-to-install-solar-panels/>; <https://offgriddiy.co.za/protection-of-off-grid-solar-pv-systems/>

5.2.6. Commissioning of Solar System -

Stage Five

Once all connections as described above are done and the energy meter is replaced with a two-way electrometers meter, the system is ready for charging and generation. The output voltage of the DC strings and the phase sequence of AC connection is checked before the inverter is switched on. The digital display on the inverter is used to monitor the units



generated and basic voltage & current parameters, to confirm that the system is functioning smoothly.



Figure: The inverter's digital display is used to monitor and control the main voltage and current parameters to ensure normal/optimal system operation.

source: https://www.soropower.com/technical_topics/principle-and-application-of-solar-inverter.html

The inverter is then connected to the internet using a WiFi signal available at the inverter location, or using a sim-based dongle. Internet connection is required for real-time online monitoring of plant performance. This helps to identify issues in generation and rectify them at the earliest to minimize downtime.

Conclusion

In summary, a good quality solar installation is nothing but the result of good planning and execution. It starts with thorough system design to evaluate shadows, ensure mounting structure stability in wind loads, and careful selection of electrical components. A well-trained professional team must then be engaged to ensure correct handling of all components and flawless project execution following all Standard Operating Procedures.

5.2. Basic stages of building a small photovoltaic system.

ORGANIZATION AND MANAGEMENT OF THE PHOTOVOLTAIC SYSTEM.



Co-funded by
the European Union

Funded by the European Union. Views and opinions expressed are however those of the author(s) only and do not necessarily reflect those of the European Union or the European Education and Culture Executive Agency (EACEA). Neither the European Union nor EACEA can be held responsible for them.

All the recommendations made in this part will not be useful if maintenance and repair activities are not foreseen after the construction of each photovoltaic installation. Simply following the recommended measures set out in this part, presented and collected here, alone cannot guarantee good operation of the photovoltaic installation. Photovoltaic systems must comply with national rules for the construction of electrical networks, which include preventive and corrective activities to detect and eliminate accidents and interruptions occurring during normal operation. It is recommended to preparing a monitoring system to be managed by qualified personnel capable of warning of malfunctions in the operation of the photovoltaic installation. It is important to periodically check the condition and operating conditions of modules, inverters, cables, connectors, etc. Only in this way will the installation work properly and the operational life will be long, reaching a high percentage of suitability, high parameters of energy production and, accordingly, a lower price of photovoltaic generated solar energy.



Figure: The quality and successful operation of a PV system depends on its proper organization and management. source: <https://www.intertek.com/solar/>